

SOUTHERN CALIFORNIA EDISON
TRANSMISSION AND DISTRIBUTION

Distribution Overhead
Construction Standards
(DOH)

2019 — FIRST QUARTER ISSUE
January 25, 2019

***Note:** Printed and downloaded versions of this document are uncontrolled. In the case of a conflict between printed/downloaded and electronic versions of this document, the controlled version published on the Company portal prevails.*

Copyright © 2019 Southern California Edison. All rights reserved.

No part of this document may be reproduced, stored in a retrieval system, or transmitted, in any form or by any means, without the prior written permission of Southern California Edison.

Direct technical questions/comments to:
Juan Castaneda, Transmission & Substation Standards
PAX 61705 • Voice: (909) 274-1705 • Email: juan.castaneda@sce.com

Published by:
Transmission & Distribution • Southern California Edison
Standards & Publications, 1 Innovation Way, Pomona, California 91768-2560

Distribution Overhead Construction Standards (DOH)

Revision Summary

2019 — First Quarter Issue

Effective Date: January 25, 2019

Overview

The main purpose of this revision summary is to describe new revisions to this manual. (Some or all of the information may have been previously communicated to field personnel by other means.)

[Table 1](#) lists the revisions. Clickable page/sheet numbers link directly to individual revisions or the first of a series of revisions.

[Table 2](#) defines four types of revisions: (1) Admin (Administrative), (2) Technical, (3) New, and (4) Pilot.

Note: *Admin and Technical revisions to existing standards or existing Pilot projects are identified with change bars | in the left margin. New standards (as well as new pilot projects) do not receive change bars. Editorial revisions, such as corrections to spelling, do not receive change bars.*

A [Getting Help](#) section provides contact information.

Table 1: Revisions

Division Standard	Page/Sheet	Description	Type
AP 106	1, 3–4	Figure AP 106-1 was made “For Reference Only”. Tables 2 and 3 were updated to align with PLM-2, Tables 5 and 6, respectively.	Admin
AP 300	9–10	Updated application description for transmission pole switch to allow for use on congested distribution poles requiring additional climbing clearance. Removed “Coastal” from SAP 10172425 switch.	Admin
AP 337	7–8	Added new Scope AP 337.4 detailing automated 600 A, 17 kV Vertical Dual Circuit Switch construction. Added related notes to new scope. All scope and figure numbers have been adjusted.	Technical
AP 410	2–3	Table AP 410-1 was updated for clarity and Table AP 410-2 was added to the standards for the Cal-Fire Exempt Arrester Pilot.	Technical
AP 505	ALL	Standard will now be “For Reference Only”.	Technical
AP 510	ALL	Various changes and additions have been made in order to consolidate construction standards for Remote Automatic Recloser (RAR) and Remote Sectionalizing Recloser (RSR) into a single standard. New scopes, figures and notes have been taken from AP 505 and added to AP 510 for 4 kV with Neutral Sensing, 25 kV, and 33 kV installations.	Technical

Table 1: Revisions (Continued)

Division Standard	Page/Sheet	Description	Type
AP 620P	16, 18	Updated note a/ for Table AP 620P-3. Added new Subsection 3.6 for details on installation of Linescope Lineprobe Sensors on covered conductors.	Admin
CC 100	ALL	General information on covered conductor has been updated to match information in DDS. Added new information on 35 kV rated covered conductor.	Technical
CC 110	ALL	Added cable data for 35 kV rated covered conductor. Created separate scope for 17 kV rated covered conductor.	Technical
CC 120	ALL	Added new details regarding use of dynamometer and sag boards. Added new references to sag and tension scopes.	Technical
CC 130	ALL	Added new information regarding what apparatus requires use of surge arresters in covered conductor systems.	Technical
CC 140	ALL	Removed grounding information. Added new figure depicting placement of “N” sign in covered conductor system. Added new information regarding use of “N” sign for all crossarms in a covered conductor system.	Technical
CC 150	ALL	Updated section to include additional details on use of polymer, vice-top, and nylon insert insulators. Added new figure depicting use of dead-end coverings.	Technical
CC 160	ALL	Section Removed from Manual.	Technical
CC 170	1, 3	Updated Table CC 170-1. Added new Table CC 170-3 for information on splice covering kit of 35 kV rated covered conductor. Other minor edits.	Technical
CC 180	ALL	Added new figure depicting transition from covered conductor system to bare wire.	Technical
CO 104	1	Minor edit to Section 1.0 to include the use of bare of covered conductor in areas within one mile of the ocean.	Technical
CO 108	1	Added new Subsection 1.2 for requiring use of copper secondary’s in areas with high vegetation and rodent population and when replacing aluminum secondary’s due to rodent damage.	Technical
CO 110	1	Added new stringing tensions for all Copper covered conductor sizes.	Technical
CO 140	2–9	Updated and added new tables for sag and tension values for 17 kV rated and 35 kV rated 1/0 and 336 ACSR Covered Conductor in light loading areas.	Technical
CO 142	2–5	Updated and added new tables for sag and tension values for 17 kV rated and 35 kV rated 653 ACSR Covered Conductor in light-loading areas.	Technical

Table 1: Revisions (Continued)

Division Standard	Page/Sheet	Description	Type
CO 148	2-7	Updated and added new tables for sag and tension values for 17 kV rated #2, 2/0 and 4/0 copper Covered Conductor in light-loading areas.	Technical
CO 152	2-3	Updated and added new tables for sag and tension values for 17 kV rated #2 copper Covered Conductor in heavy-loading areas.	Technical
CO 160	2-5	Updated and added new tables for sag and tension values for 17 kV rated 2/0 and 4/0 copper Covered Conductor in heavy-loading areas.	Technical
CO 162	2-5	Updated and added sag and tension tables for 17 kV and 35 kV rated 1/0 ACSR Covered Conductor in heavy-loading areas.	Technical
CO 164	2-5	Updated and added sag and tension tables for 17 kV and 35 kV rated 336 ACSR Covered Conductor in heavy-loading areas.	Technical
CO 166	2-5	Updated and added sag and tension tables for 17 kV and 35 kV rated 653 ACSR Covered Conductor in heavy-loading areas.	Technical
CO 168	Various	Added various sag and tension tables for all guying scopes for 17 kV and 35 kV rated covered conductor.	Technical
CO 300	ALL	Updated various figures with photos of connectors.	Admin
CO 305	ALL	Updated various figures with photos of connectors.	Admin
CO 410	Various	Updated various figures with photos of connectors. Updated Tables 1-4.	Admin
CO 460	ALL	Initial Issue for Spiral Vibration Dampers.	New
CO 700	8-11	Figures of PUPI mounting brackets were updated to show rounded edges.	Admin
DC 222	2 8	Subsection 3.2 was updated for clarity. Figure DC 222-2 Note 6 has been updated for clarity.	Admin
DC 321	2	Figure DC 321-2 Note 1 was updated to include more conductors.	Admin
DC 535	1-2	Added new Subsection 1.4 for requiring use of copper secondary's in areas with high vegetation and rodent population and when replacing aluminum secondary's due to rodent damage. Added standard construction practice for not requiring use of wildlife hoods for covered conductor systems.	Technical
GR 110	3	New scope clarifying 4 kV common neutral signs.	Admin
GR 200	6	Updated table note a/.	Technical

Table 1: Revisions (Continued)

Division Standard	Page/Sheet	Description	Type
PO 130	2	Subsection 2.6 and Figure PO 130-2.3 have been updated for clarity.	Admin
PO 310	2	Subsection 3.7 was updated for clarity.	Admin
PO 350	2	Text was updated for clarity.	Admin
PO 360	2	Updated Figure PO 360-1.	Admin
PO 370	2, 7–8, 10	Figure PO 370-2 has been updated to clarify working load capacity. Revised Figure PO 370-11 and added clarity on use of guying tee. Removed Angled thimble eye figure and reference in Section 11.0 and figure PO 370-13. Revised Figure PO 370-17.	Admin

Table 2: Revision Types

Type	Definition
Admin	Administrative revisions do not significantly affect design, construction, maintenance or operation of the electrical distribution, substation, and transmission systems. They do not require Standards Review Team (SRT) or management approval; however, they have been approved by other organizations, as appropriate. They may include updates to material codes, updates to references, updates to standards for clarity, or deletions of outdated information.
Technical	Technical revisions are engineering changes to existing standards. They affect the design, construction, maintenance or operation of the electrical distribution, substation, and transmission systems. They require SRT and management approval.
New	Refers to a new standard. New technical standards require SRT and management approval.
Pilot	A <i>Pilot</i> is an in-field evaluation of a piece of equipment or work method, with the intention of approving for standardized use. Pilot standards will have a PILOT watermark so that they are easily identified throughout this manual.

Getting Help

Technical Revisions

If you have any comments, corrections, questions, or suggestions concerning manual revisions, please contact one of the following individuals at the numbers provided, or click on the name to send an email:

- [Juan Castaneda](#) (Manager) — PAX: 54782 Outside: (714) 895-0782
- [Alaira Bilek](#) — PAX: 54156 Outside: (714) 895-0156
- [Gabriel Mercado](#) — PAX: 54706 Outside: (714) 895-0198
- [Jaimen Sanders](#) — PAX: 54142 Outside: (714) 895-0142



Allen Thiel
Principal Manager Lead, Engineering

This page intentionally left blank.

DI — Division Index

Section	Tab
DI: Division Index	Division Index
AC: Aerial Cable	AC
AP: Apparatus	AP
CC: Covered Conductor	CC
CO: Conductors and Splices	CO
DC: Distribution Construction	DC
GR: Grounding Bonds and Insulators	GR
PO: Poles and Guying	PO
PR: Protection (Fusing)	PR
SL: Street Lighting	SL
T: Testing and Metering	T
ISGD: Irvine Smart Grid Demonstration	ISGD
DESI: Distribution Energy Storage Integration	DESI
IGP: Integrated Grid Project	IGP

Approved by:	Division Index	DI
Effective Date:		Sheet 1 of 1
01-25-2019		DOH

This page intentionally left blank.

DOH-AP: Apparatus

TABLE OF CONTENTS

<u>STANDARD</u>	<u>TITLE</u>
AP 100	Transformer Connections Two in Parallel — 4160/2400 Y
AP 100.1	Connections for Parallel Operation of Two 1Ø Transformers with 120/240 V Secondary
AP 105	Typical Pole Framing for Transformers Bolted to Crossarms or Supported by Hangers
AP 105.1	Method of Framing for 3Ø Transformer Banks 4,200 Pounds Maximum Weight
AP 105.2	Method of Framing for 3Ø Transformer Banks 2,250 Pounds Maximum Weight
AP 105.3	Method of Framing for 3Ø Transformer Banks 3,000 Pounds Maximum Weight
AP 106	Transformer Polemounting and Weight Limitations
AP 106.1	Minimum Pole Diameters and Maximum Transformer Weights for Installing Transformers on Wood Poles
AP 106.2	Transformer Extension Bracket
AP 108	Typical Overhead Transformer Weights and Dimensions
AP 108.1	Typical Transformer Dimensions
AP 109	Single-Phase Overhead Transformers (All Primary Voltages)
AP 109.1	Single-Phase Overhead Transformer
AP 110	2.4 kV — 1Ø Transformer
AP 110.1	Typical Installation of 2.4 kV Pole-Mounted Transformers
AP 112	2.4 kV — 2-1Ø Transformers — Open Delta
AP 112.1	Typical 2.4 kV — 2-1Ø Transformers — Open Delta
AP 114	2.4 kV — 2-1Ø Transformer — Two in Parallel
AP 114.1	Typical Installation and Wiring Diagram of 2-1Ø — 2.4 kV Transformers — Two in Parallel
AP 116	2.4 kV — 3-1Ø Transformer — Closed Delta
AP 116.1	Typical 2.4 kV — 3-1Ø Transformer — Typical Wiring Diagrams
AP 120	12/16 kV — 1Ø Transformer — Conventional (above 2.4/4 kV Primary)
AP 120.1	Typical Installation of 12/16 kV — 1Ø Transformer — Conventional (above 2.4/4 kV Primary)
AP 122	12/16 kV — 2-1Ø Transformers — Open Delta
AP 122.1	Typical 12/16 kV — 2-1Ø Transformers — Open Delta
AP 124	12/16 kV — 1Ø Transformer — Vertical Construction
AP 124.1	Typical Installation of 12/16 kV — 1Ø Transformer — Vertical Construction
AP 126	12/16 kV — 1Ø Transformer — Transmission Pole
AP 126.1	Typical 12/16 kV — 1Ø Transformer — Transmission Pole
AP 128	12/16 kV — 3-1Ø Transformer — Transmission Pole
AP 128.1	Typical 12/16 kV — 3-1Ø Transformer — Transmission Pole
AP 130	12/16 kV — FI — Transformer — Directly on Pole
AP 130.1	12/16 kV — FI — Transformer — Directly on Pole

Approved by:	Apparatus Table of Contents	AP
Effective Date:		Sheet 1 of 10
01-25-2019		DOH

STANDARD	TITLE
AP 131	Cluster Mounting Bracket for Transformer Banks (Up to 5,000 lb Max)
AP 131.1	Cluster Mounting Bracket for Transformer Banks (Up to 5,000 lb Max)
AP 132	3-1Ø Heavy and Light Duty Transformer Mounting Brackets
AP 132.1	Heavy and Light Duty Transformer Mounting Brackets Installing 3-1Ø, Transformers
AP 133	Hanging Bracket Restraint Installation on Scott Brackets with Plastic Pads
AP 133.1	Application and Installation of Hanging Bracket (HB) Restraints on Overhead (OH) Transformers Mounted on Scott Transformer Brackets with Plastic Pads
AP 134	12/16 kV — 1Ø Transformer — Steel Arm Construction
AP 134.1	12/16 kV — 1Ø Transformer — Steel Arm Construction
AP 136	12/16 kV — 3-1Ø Transformer — 13'-6" Platform
AP 136.1	12/16 kV — 3-1Ø Transformer — 13'-6" Platform
AP 140	33 kV Bank — 3-1Ø Transformers — on 15-Foot Platform
AP 140.1	33 kV Bank — 3-1Ø Transformers — on 15-Foot Platform
AP 145	3-1Ø Transformers — 17'-4" Platform Rack
AP 145.1	3-1Ø Transformers — 17'-4" Platform Rack
AP 150	167 kVA, 12/16 kV through 6.9/9.4 kV Step-Down Transformer
AP 150.1	167 kVA, 12/16 kV through 6.9/9.4 kV Step-Down Transformer
AP 152	250 kVA–333 kVA, 12/16 kV through 6.9/9.4 kV Step-Down Transformer
AP 152.1	250 kVA–333 kVA, 12/16 kV through 6.9/9.4 kV Step-Down Transformer
AP 160	12/16 kV Qualifying Facility (QF) Ground Bank
AP 160.1	Connections for Installing Qualifying Facility (QF) Ground Bank on Overhead 12/16 kV Four-Wire Systems — Pole-Mounted
AP 160.2	Connections for Installing Qualifying Facility (QF) Ground Bank on Overhead 12/16 kV Four-Wire Systems — Platform-Mounted
AP 165	12/16 kV and 33 kV Ground Fault Detector
AP 165.1	12/16 kV and 33 kV QF/WDAT Ground Fault Detector — Pole-Mounted
AP 165.2	12/16 kV and 33 kV Alternate Voltage Sensing Bank for Automatic Reclosers
AP 166	2.4 kV and 4.8 kV Ground Fault Detector
AP 166.1	2.4 kV and 4.8 kV Ground Fault Detector
AP 180	Line Voltage Regulators
AP 180.1	Line Voltage Regulators
AP 180.2	Single Phase Voltage Regulators
AP 180.3	Open Delta Voltage Regulators
AP 180.4	Closed Delta Voltage Regulators
AP 180.5	Wye Configuration Voltage Regulators
AP 180.6	33 kV Surface Mounted Voltage Regulators
AP 200	Capacitor Bank Material List
AP 200.1	Capacitor Bank Material List

AP	Apparatus Table of Contents	Approved by: <i>ajf</i>
	Sheet 2 of 10	Effective Date: 01-25-2019
DOH		

STANDARD	TITLE
AP 210	2.4 kV, 4.16 kV, 4.8 kV, 12 kV, and 16 kV — Fixed Capacitors
AP 210.1	Installation of 2.4 kV, 4.16 kV, 4.8 kV, 12 kV, and 16 kV — Fixed Capacitors with Surge Arresters
AP 210.2	2.4 kV, 4 kV, 4.8 kV, 12 kV, and 16 kV — Fixed Capacitors without Surge Arresters
AP 212	12/16 kV — Fixed Capacitors with Surge Arresters — High Fire Hazard Area
AP 212.1	12/16 kV — Fixed Capacitors with Surge Arresters — High Fire Hazard Area
AP 216	Three-Unit Cradle-Type Rack from Four-Unit Cantilever-Type Rack — 12/16 kV — Fixed Caps — Preassembled — High Fire Hazard Area — 300 kVAR, 600 kVAR, 900 kVAR, and 1200 kVAR Banks with Conventional 1Ø Units
AP 216.1	Three-Unit Cradle-Type Rack from Four-Unit Cantilever-Type Rack — 12/16 kV — Fixed Caps — Preassembled — High Fire Hazard Area — 300 kVAR, 600 kVAR, 900 kVAR, and 1200 kVAR Banks with Conventional 1Ø Units
AP 217	Four-Unit Cantilever-Type Rack — 12/16 kV — Fixed Caps — Preassembled — High Fire Hazard Area — 900 kVAR and 1200 kVAR Banks with Cantilever-Mounted 300 kVAR or 400 kVAR 1Ø Units
AP 217.1	Four-Unit Cantilever-Type Rack — 12/16 kV — Fixed Caps — Preassembled — High Fire Hazard Area — 900 kVAR and 1200 kVAR Banks with Cantilever-Mounted 300 kVAR or 400 kVAR 1Ø Units
AP 218	Three-Unit Cradle-Type Rack Modified from Four-Unit Cantilever-Type Rack — 12/16 kV — Fixed Caps — Preassembled — 300 kVAR, 600 kVAR, 900 kVAR, and 1200 kVAR Banks with Conventional 1Ø Units
AP 218.1	Three-Unit Cradle-Type Rack Modified from Four-Unit Cantilever-Type Rack — 12/16 kV — Fixed Caps — Preassembled — 300 kVAR, 600 kVAR, 900 kVAR, and 1200 kVAR Banks with Conventional 1Ø Units
AP 219	Four-Unit Cantilever-Type Rack — 12/16 kV — Fixed Caps — Preassembled — 900 kVAR and 1200 kVAR Banks with Cantilever-Mounted 300 kVAR or 400 kVAR 1Ø Units
AP 219.1	Four-Unit Cantilever-Type Rack — 12/16 kV — Fixed Caps — Preassembled — 900 kVAR and 1200 kVAR Banks with Cantilever-Mounted 300 kVAR or 400 kVAR 1Ø Units
AP 220	4 kV, 12 kV, and 16 kV — Switched Capacitors
AP 220.1	Installation of 4 kV, 12 kV, and 16 kV — Switched Capacitors with Surge Arresters
AP 220.2	4 kV, 12 kV, and 16 kV — Switched Capacitors without Surge Arresters
AP 221	2.4 kV and 4.8 kV — Switched Capacitors
AP 221.1	Installation of 2.4 kV and 4.8 kV — Switched Capacitors with Surge Arresters
AP 222	4.16 kV, 12 kV, and 16 kV — Switched Capacitors with Two Switches
AP 222.1	4.16 kV, 12 kV, and 16 kV — Switched Capacitors with Two Switches with Surge Arresters
AP 223P	33 kV Switched Capacitor Bank
AP 223P.1	33 kV Switched Capacitor Bank with 3Ø Switch on 17'-4" Platform

Approved by: <i>ajf</i>	Apparatus Table of Contents	AP
Effective Date: 01-25-2019		Sheet 3 of 10
		DOH

STANDARD	TITLE
AP 224	Switched Capacitor Banks on Transmission Poles
AP 224.1	Installation Procedures for S&C Bankgard Relay Type Capacitor Voltage Unbalance Relay (LUC) with Switched Capacitor Banks Mounted on Transmission Poles
AP 224.2	Wiring Schematic and Testing Procedures for S&C Bankgard Relay Type LUC with Switched Capacitor Banks Mounted on Transmission Poles
AP 224.3	Installation Procedures for S&C Bankgard Relay Type LUC with Switched Capacitor Banks Mounted on Transmission Poles
AP 224.4	Installation Procedures for Fisher-Pierce PCC with Unbalanced Voltage Sensing Switched Capacitor Banks Mounted on Transmission Poles
AP 224.5	Switched Capacitors — Control Wiring
AP 224.6	Switched Capacitors — Testing
AP 225	25 kV — Switched Capacitors with Three Switches
AP 225.1	25 kV — Switched Capacitors with Three Switches with Surge Arresters
AP 226	Three-Unit Cradle-Type Rack Modified from Four-Unit Cantilever-Type Rack 12/16 kV Switched — Caps Preassembled 300 kVAR, 600 kVAR, 900 kVAR, or 1200 kVAR Banks with Conventional 1Ø Units
AP 226.1	Three-Unit Cradle-Type Rack Modified from Four-Unit Cantilever-Type Rack 12/16 kV Switched — Caps Preassembled 300 kVAR, 600 kVAR, 900 kVAR, or 1200 kVAR Banks with Conventional 1Ø Units
AP 227	Four-Unit Cantilever-Type Rack 12/16 kV Switched — Caps Preassembled 900 kVAR and 1200 kVAR Banks with Cantilever-Mounted 300 kVAR or 400 kVAR 1Ø Units
AP 227.1	Four-Unit Cantilever-Type Rack 12/16 kV Switched — Caps Preassembled 900 kVAR and 1200 kVAR Banks with Cantilever-Mounted 300 kVAR or 400 kVAR 1Ø Units
AP 229	Capacitor Rack Adapter Mounting Frame to Convert Cantilever Mounting to Cradle Mounting
AP 229.1	Capacitor Rack Adapter Mounting Frame to Convert Cantilever Mounting to Cradle Mounting
AP 230	Switched Capacitors — Control Wiring
AP 230.1	Switched Capacitors — Control Wiring
AP 231	Switched Capacitors — Control Wiring
AP 231.1	Switched Capacitors — Control Wiring
AP 300	Pole-Top Gang-Operated Switches
AP 300.1	Pole-Top Gang-Operated Switches Application
AP 300.2	Pole Top Gang-Operated Switches
AP 300.3	Pole-Top Gang-Operated Switches Application Table
AP 310	Tilting Insulator Type Pole-Top Switch
AP 310.1	Tilting Insulator Type Pole-Top Switch
AP 312	Horizontal Type “A” KPF Switch
AP 312.1	Typical Mounting Horizontal Type “A” KPF Switch
AP 314	Mounting Vertical Type “A” KPF Switch
AP 314.1	Mounting Vertical Type “A” KPF Switch
AP 320	Bell Crank Mounting — KPF Switches
AP 320.1	Bell Crank Mounting — KPF Switches

STANDARD	TITLE
AP 325	Line or Elevation Angles Switches
AP 325.1	Line or Elevations Angles Switches
AP 330	Quick Break Attachment — KPF Switch
AP 330.1	Quick Break Attachment — KPF Switch
AP 332	Alternate Methods of Connecting Line to KPF Type Switches
AP 332.1	Alternate Methods of Terminations on KPF Air Break Switch
AP 335	Hook-Stick–Operated Single-Blade Disconnect Switch
AP 335.1	Installation and Applications of Hook-Stick–Operated Single-Blade Disconnect Switches
AP 336	600 A, 17 kV Omni-Rupter Load-Break Switches
AP 336.1	Horizontal Inverted Omni-Rupter Switch, Line Dead-Ended Directly to Switch
AP 336.2	Horizontal Inverted Omni-Rupter Switch Below Line Arm, Utilizing Hughes Adapter
AP 336.3	Installation of Hughes Adapter for Inverted Omni-Rupter Switches Installed Below the Line Arm
AP 336.4	Horizontal Side Arm Omni-Rupter Switch, Primary Dip Application
AP 336.5	Vertical Inverted Omni-Rupter Switch
AP 336.6	Horizontal Inverted Omni-Rupter 4-Pole Switch, for 4 kV Isolated Neutral Systems
AP 336.7	Horizontal-Type Inverted Configuration, 600 A, 17 kV, Omni-Rupter Load-Break Switch for Wildlife-Safe Construction on 3-Wire or 4-Wire Pole Applications
AP 336.8	Horizontal-Type Upright Configuration, 600 A, 17 kV, Omni-Rupter Load-Break Switch for 3-Wire or 4-Wire Pole-Top Applications
AP 336.9	Horizontal-Type Upright Configuration, 600 A, 17 kV, Omni-Rupter Load-Break Switch for 3-Wire or 4-Wire Pole-Top Applications
AP 337	Automated 600 A, 17 kV Omni-Rupter Load-Break Switches
AP 337.1	Automation Equipment Information for 600 A, 17 kV Omni-Rupter Load-Break Switches
AP 337.2	Automated Horizontal Inverted Omni-Rupter Switch, Line Dead-Ended Directly to Switch
AP 337.3	Automated Vertical Inverted Omni-Rupter Switch
AP 337.4	Automated 600 A, 17 kV Omni-Rupter Vertical Dual Circuit Switch
AP 337.5	Typical Automation Common Equipment Grounding Connections for 600 A, 17 kV Omni-Rupter Load-Break Switches
AP 337.6	Automated Horizontal-Type Upright Configuration, 600 A, 17 kV, Omni-Rupter Load-Break Switch Dead-Ended on Switch Base
AP 337.7	Automated Horizontal-Type Upright Configuration, 600 A, 17 kV, Omni-Rupter Load-Break Switch Dead-Ended on Switch Base
AP 337.8	Automated Horizontal-Type Upright Configuration, 600 A, 17 kV, Omni-Rupter Switch Below Existing Line Arm, Underbuild
AP 337.9	Automated Horizontal-Type Upright Configuration, 600 A, 17 kV, Omni-Rupter Load-Break Switch Below Existing Line Arm

Approved by: <i>ajf</i>	Apparatus Table of Contents	AP
Effective Date: 01-25-2019		Sheet 5 of 10
		DOH

STANDARD	TITLE
AP 338	600 A, 38 kV Alduti-Rupter Load-Break Switches
AP 338.1	Horizontal Inverted Alduti-Rupter Switch
AP 338.3	Vertical Alduti-Rupter Switch
AP 338.4	Horizontal-Type Upright Configuration, 600 A, 17 kV, Omni-Rupter Load-Break Switch for 3-Wire or 4-Wire Pole-Top Applications
AP 338.5	Horizontal Side-Arm Configuration Upright-Type, 600 A, 38 kV, Alduti-Rupter Load-Break Switch for 3 Pole-Top Application
AP 339	Automated 600 A, 38 kV Alduti-Rupter Load-Break Switches
AP 339.1	Automation Equipment Information for 600 A, 38 kV Alduti-Rupter Load-Break Switches
AP 339.2	Automated Horizontal Inverted Alduti-Rupter Switch
AP 339.3	Automated Vertical Inverted Alduti-Rupter Load-Break Switch
AP 339.4	Typical Automation Common Equipment Grounding Connections for 600 A, 38 kV Alduti-Rupter Load-Break Switch
AP 339.5	Automated Horizontal Inverted Alduti-Rupter Switch
AP 339.6	Automated Horizontal Side-Arm Configuration Upright-Type, 600A, 38 kV, Alduti-Rupter Load-Break Switch for 3-Wire Pole Application
AP 340P	600 A, 25 kV Inertia LineBoss Overhead Load-Break Switches
AP 340P.1	Horizontal-Type Inverted Configuration, 600 A, 25 kV, Inertia LineBoss Load-Break Switch, Line Dead-Ended Directly to Switch, For 12 kV and 16 kV Applications
AP 360	Cleveland/Price ADMO Remote Controlled Switch Operator for Omni-Rupter Type Switches
AP 360.1	Installation Procedure for Cleveland/Price ADMO Switch Operator
AP 360.2	Sample Preinstallation and Inspection Check Sheet for Installation of Cleveland/Price Automatic Distribution Motor Operation (ADMO)
AP 360.3	Final Inspection Check Sheet for Cleveland/Price Automatic Distribution Motor Operator (ADMO)
AP 360.4	Cleveland/Price Automatic Distribution Switch Operator ADMO Type BR
AP 360.5	ADMO Connection Detail
AP 360.6	ADMO Manual Operation Mechanism
AP 362	4 kV Oil Filled Voltage Transformer Installation for Omni-Rupter Switch Automation
AP 362.1	4 kV Oil Filled Voltage Transformer Installation for Omni-Rupter Switch Automation
AP 363	4/12/16 kV Dry Type VT Installation for Switch Automation
AP 363.1	4/12/16 kV Dry Type VT Installation for Switch Automation
AP 363.2	4 kV Dry Type VT Nameplate, Secondary Terminal and Wiring Details
AP 363.3	12/16 kV Dry Type VT Nameplate, Secondary Terminal and Wiring Details
AP 365	33 kV VT Installation for Switch Automation
AP 365.1	33 kV Dry Type VT Installation for Switch Automation
AP 400	Surge Arrester Application Guide
AP 400.1	Application Guide for Distribution Surge Arresters

<u>STANDARD</u>	<u>TITLE</u>
AP 405	Surge Arrester Identification — Examples
AP 405.1	For Identification of Metal Oxide Varister Surge Arrester and Mounting Hardware
AP 405.2	Arrester Identification — Examples
AP 410	Distribution Class Surge Arrester Guide
AP 410.1	Distribution Class Surge Arrester Guide
AP 415P	Cal-Fire Exempt Lighting Arresters for Use in Bulletin 322 Areas
AP 415P	Cal-Fire Exempt Lighting Arresters for Use in Bulletin 322 Areas
AP 420	Preferred Method — Installing Fuseholders with Surge Arresters
AP 420.1	Preferred Method — Installing Fuseholders with Surge Arresters
AP 425	Horizontal Surge Arrester on 33 kV Line Arms
AP 425.1	Typical Horizontal Surge Arrester on 33 kV Line Arms
AP 430	Surge Arresters with 1Ø Conventional Transformer
AP 430.1	Surge Arresters with 1Ø Conventional Transformer
AP 431	Surge Arresters on Subtransmission Lightweight Steel (LWS) Poles with 1Ø Conventional Transformer
AP 431.1	Surge Arresters on Subtransmission LWS Poles with 1Ø Conventional Transformer
AP 432	Surge Arresters with 1Ø “CSP” Transformer
AP 432.1	Surge Arresters with 1Ø “CSP” Transformer
AP 434	Surge Arresters with 3Ø Conventional Transformer
AP 434.1	Surge Arresters with 3Ø Conventional Transformer
AP 434.2	Surge Arresters with 3Ø Conventional Transformers
AP 436	Surge Arresters with 1Ø — 33 kV Transformer
AP 436.1	Typical Installation of a 33 kV — 1Ø Transformer with Surge Arresters
AP 502	Single Phase Overhead Electronic Reclosers
AP 502.1	Single Phase Automatic Circuit Recloser (AR) Installation Details
AP 505	Three Phase Overhead Electronic Reclosers (FOR REFERENCE ONLY)
AP 505.1	Automatic Circuit Recloser (AR) Installation Details
AP 505.2	G&W Viper-S AR for 4 kV Installations
AP 505.3	G&W Viper-S AR for 4 kV Installations with Neutral Sensing CT
AP 505.4	G&W Viper-S AR for 12/16 kV Installations
AP 505.5	G&W Viper-S AR for 25 kV Installations
AP 505.6	G&W Viper-S AR for 33 kV Installations
AP 505.7	Typical AR Connections with the CPT Located on the Same Pole (Preferred Method)
AP 505.8	Typical AR Connections with the Solid Dielectric CPT Located on a Separate Pole (Alternate Method)
AP 505.9	Wiring Diagram for Titan 75LC Surge Suppressor for SEL351R
AP 505.10	Typical G&W Viper 12/16 kV Electronic ARs with the CPT Located on the Same Pole (Preferred Method)

Approved by: <i>ajf</i>	Apparatus Table of Contents	AP
Effective Date: 01-25-2019		Sheet 7 of 10
		DOH

STANDARD	TITLE
AP 505.11	Typical Cooper (McGraw-Edison) Type WE and NOVA 12/16 kV Electronic ARs with the CPT Located on the Same Pole
AP 505.12	Typical G&W Viper 38 kV Electronic AR with the CPT Located on the Same Pole (Preferred Method)
AP 505.13	Typical McGraw-Edison Type WVE38X 34.5 kV Electronic AR with the CPT Located on the Same Pole
AP 505.14	Typical AR Connections with the CPT Located on a Separate Pole (Alternate Method)
AP 505.15	Typical Method of Installing a NetComm Radio on a Form 3/3A/4C Controller
AP 505.16	Wiring Diagram for Addition of Metricom Radio to Cooper Form Electronic 4C AR
AP 505.17	Wiring Diagram for Automation Conversion of Cooper Form 3/3A Electronic ARs
AP 506P	Installation of High Impedance Fault Detection Relays
AP 506P.1	Typical Installation of Auxiliary Relay Package for High Impedance (HiZ) Fault Detection Relays
AP 507P	Installation of Voltage Abnormal Detection on Energized Radials (VADER) Alarm
AP 507P.1	Typical Installation of VADER Alarm Package
AP 510	Three Phase Overhead Remote Electronic Reclosers with Three Phase Voltage Sensing
AP 510.1	Remote Electronic Recloser Installation Details
AP 510.2	G&W Viper-S Remote Electronic Reclosers with Three Phase Voltage Sensing for 4 kV Installations
AP 510.3	G&W Viper-S Recloser for 4 kV Installations with Neutral Sensing CT
AP 510.4	G&W Viper-S Remote Electronic Reclosers with Three Phase Voltage Sensing for 12/16 kV Installations
AP 510.5	G&W Viper-S Remote Electronic Reclosers with Three Phase Voltage Sensing for 25 kV Installations
AP 510.6	G&W Viper-S Remote Electronic Reclosers with Three Phase Voltage Sensing for 33 kV Installations
AP 510.7	Control Cable and Grounding Connections
AP 515	McGraw-Edison 34.5 kV "CXE" Recloser
AP 515.1	McGraw-Edison 34.5 kV "CXE" Recloser
AP 520P	Typical Installation of Overhead TripSaver [®] II Cutout-Mounted Branch-Line Recloser
AP 520P.1	Typical TripSaver [®] II Cutout-Mounted Branch-Line Recloser Construction for 3Ø Double Dead-End Straight Line Pole on 4/12/16 kV Systems
AP 520P.2	Typical TripSaver [®] II Cutout-Mounted Branch-Line Recloser Construction for 1Ø/3Ø Break-Off Pole on 4/12/16 kV Systems
AP 525P	Typical Installation of Automated Overhead Fusesaver [®] Branch-Line Recloser
AP 525P.1	Typical Automated Fusesaver [®] Branch-Line Recloser Construction for 1Ø/3Ø Break-Off Pole on 4/12/16 kV Systems
AP 525	Customer Windpark Interconnection Generation Facilities with SCE-Owned Equipment
AP 525.1	Customer Windpark Interconnection Generation Facilities with SCE-Owned Equipment

<u>STANDARD</u>	<u>TITLE</u>
AP 600	Installation of Fault Indicators for Overhead Conductors
AP 600.1	Installation of Fault Indicators for Overhead Conductors
AP 603	Installation of Remotely Indicating Faulted Circuit Indicator (FCI) in the Overhead Remotely Controlled Switch (RCS) Operators
AP 603.1	Installation of Fault Indicators for Overhead Conductors
AP 604	Sentient Energy MM3 Remote Fault Indicator (RFI)
AP 604.1	Installation of Sentient Energy MM3 Remote Fault Indicator
AP 605	CHK Fault Indicator
AP 605.1	Application and Installation Procedures for the CHK Overhead Fault Indicator
AP 610	GridSense Remote Fault Indicator (RFI) Line Monitoring System
AP 610.1	Installation of the GridSense LIQ-60 Line Monitoring System
AP 610.2	Installation of the GridSense Line Monitoring System (FOR REFERENCE ONLY)
AP 620P	Cleaveland/Price Linescope Lineprobe Sensor for 12 kV and 16 kV 3-Phase 4-Wire Horizontal Construction Applications
AP 620P.1	Installation Procedure for Cleaveland/Price Linescope Lineprobe Sensor for 12 kV and 16 kV 3-Phase 4-Wire Horizontal Construction Applications
AP 700	NETCOMM Radio — General Information
AP 700.1	Typical Installations of Network Communication (NETCOMM) Radios
AP 700.2	SCE NETCOMM Antenna Assembly for Standpipe Vent Installation
AP 700.3	SCE NETCOMM Antenna Housing for 8" Steel Vent Pipe Installation
AP 700.4	NETCOMM Radio Pedestal Enclosure for 13" × 24" Handhole
AP 700.5	Solar Power Supply for Power to NETCOMM Radios where no AC Power Exists
AP 700.6	Solar Power Supply for Power to Netcomm Radios where No AC Power Exists — with Faulted Circuit Indicators
AP 700.7	Instructions for Mounting the Radome Antenna on Pad-Mounted Equipment
AP 700.8	Typical Installations of Network Communications Packet Routing Radios and Voltage Transformers 12/16 kV with Remote Fault Indicators
AP 700.9	Typical Installations of Network Communications Packet Routing Radios and Voltage Transformers 12/16 kV
AP 700.10	Instructions for Mounting the Maxrad Low Profile Antenna in OH and UG Applications
AP 705	NetComm Over Satellite Assembly — General Information
AP 705.1	Typical Installation for NetComm Over Satellite Assembly
AP 707P	On-Ramp Over Satellite Pilot Assembly — General Information
AP 707P.1	33 kV Installation for On-Ramp Communication Over Satellite Pilot
AP 707P.2	Fault Indicator Installation
AP 710	SmartConnect Range Extender – General Information
AP 710.1	Typical Installation of SmartConnect Range Extender
AP 710.2	Typical Installations of SmartConnect Range Extender Using Voltage Transformers — 12/16 kV

Approved by: <i>ajf</i>	Apparatus Table of Contents	AP
Effective Date: 01-25-2019		Sheet 9 of 10
		DOH

STANDARD	TITLE
AP 712P	Solar Powered Assembly with RRE — General Information
AP 712P.1	Typical Installation for Solar Powered Assembly with RRE on Wood Pole
AP 715	SmartConnect Broadband Global Area Network (BGAN) Satellite Assembly — General Information
AP 715.1	Typical Installation for the Broadband Global Area Network (BGAN) Satellite Assembly with Terminal and OpenWay Cell Relay Units
AP 720	SmartConnect Socket Based Polemounted Cell Relay — General Information
AP 720.1	Typical Method for Installing Single Phase, Socket Based Polemounted Cell Relay
AP 800	SCE Service to Non-Metered Cellular Service
AP 800.1	Typical Wood Pole Riser to Non-Metered Cellular Service
AP 810P	Weather Monitoring System
AP 810P.1	Weather Monitoring System

AP	Apparatus Table of Contents	Approved by: <i>ajf</i>
	Sheet 10 of 10	Effective Date: 01-25-2019
DOH		

AP 106 Transformer Polemounting and Weight Limitations

Scope AP 106.1 Minimum Pole Diameters and Maximum Transformer Weights for Installing Transformers on Wood Poles

Figure AP 106-1: Minimum Pole Diameters and Maximum Transformer Weights for Installing Transformers on Wood Poles

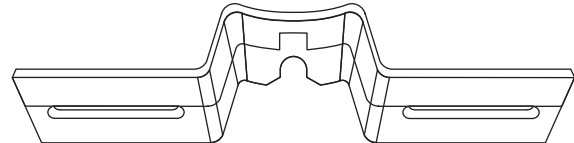
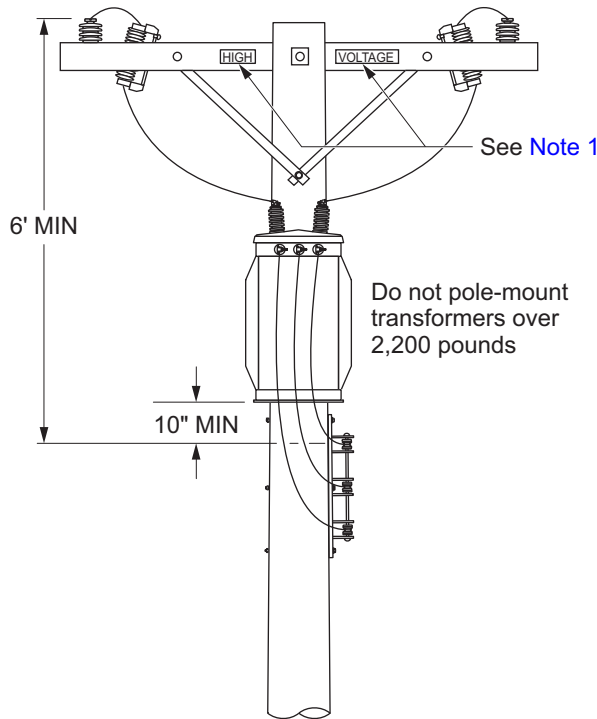

Adapter Plates for Pole-Mounting	SAP
Transformers 1,399 lb and below	10068341
Transformers 1,400 through 2,220 lb (Same upper and lower)	10068342

Note(s):

1. See [PO 120](#) for High Voltage sign installation requirements.

= For Reference Only

Approved by:

ajf

Transformer Polemounting and Weight Limitations

AP 106

Sheet 1 of 6

Effective Date:
01-25-2019

What's Changed? Figure AP 106-1 made "For Reference Only".

DOH

Table AP 106–1: Minimum Pole Diameter at Point of Transformer Attachment for Pole-Mounted Transformer

Maximum Transformer Weight			Minimum Pole Diameter (in)
Single Transformer Pole-Mounted (lb)	Single Transformer Crossarm-Mount per AP 105 (lb)	Total Weight of Transformer Bracket-Mounted per AP 132 (lb)	
1,000	—	1,620	8
1,400	2,250	2,300	9
1,500	3,000	3,150	10
1,850	4,200	4,200	11
2,200	4,200	4,200	12
2,500	4,500	4,500	13

= For Reference Only

FOR REFERENCE ONLY

Table AP 106–2: Minimum Pole Class for New Transformers and Equipment Mounted on Existing or New Wood Poles

Minimum Pole Class for New Transformers and Equipment Mounted on Existing or New Wood Poles		
Equipment Mounting Height Above Ground Line (ft)	Min. Pole Class	Transformer and/or Equipment Weight (lb)
27.5 or Below	4	Up to 1,500
	3	1,501–1,850
	2	1,851–2,500
	1	2,501–3,350
	H1	3,351–4,250
	H2	4,251–4,850
	H3	over 4,851
	H4	over 4,851
27.6–32.0	4	Up to 1,300
	3	1,301–1,700
	2	1,701–2,200
	1	2,201–3,000
	H1	3,001–3,900
	H2	3,901–4,850
	H3	over 4,851
32.1–36.5	4	Up to 1,300
	3	1,301–1,700
	2	1,701–2,200
	1	2,201–3,000
	H1	3,001–4,000
	H2	4,001–4,850
	H3	over 4,851
36.6–41.0	4	Up to 1,200
	3	1,201–1,500
	2	1,501–2,200
	1	2,201–2,500
	H1	2,501–3,350
	H2	3,351–4,250
	H3	4,250–4,850
	H4	over 4,851

Approved by:

ajf

Transformer Polemounting and Weight Limitations

AP 106

Sheet 3 of 6

Effective Date:
01-25-2019

What's Changed? Table updated to align with Pole Loading Manual, Chapter 2, Table 5.

DOH

Table AP 106–2: Minimum Pole Class for New Transformers and Equipment Mounted on Existing or New Wood Poles (Continued)

Minimum Pole Class for New Transformers and Equipment Mounted on Existing or New Wood Poles		
Equipment Mounting Height Above Ground Line (ft)	Min. Pole Class	Transformer and/or Equipment Weight (lb)
41.1–45.5	4	Up to 1,200
	3	1,201–1,500
	2	1,501–1,850
	1	1,851–2,500
	H1	2,501–3,350
	H2	3,351–4,250
	H3	4,251–4,850
	H4	over 4,851
45.6–50.0	2	Up to 1,850
	1	1,851–2,500
	H1	2,501–3,350
	H2	3,351–4,250
	H3	4,251–4,850
	H4	over 4,850

Note(s):

- For new poles, this table should be used to select pole class prior to pole loading. For existing poles with no existing transformers or equipment that are scheduled to have equipment attached, this table should be used prior to pole loading.
- Existing poles with existing transformers or equipment installed to the pole do not need to meet this table criteria, however, a visual inspection is required to ensure that there is no excessive bowing due to the installed apparatus as well as a passing pole load calculation.
- Changing like-for-like transformers or equipment requires a visual inspection and passing pole load calculation.
- This table shall be used if the existing transformers or equipment are being replaced with heavier ones. A passing pole load calculation is required.
- Refer to PLM–2, Table 7: Equipment Weights and Surface Area for equipment weights.
- A pole load calculation is required when any equipment weighing 200 lb or more is installed on a wood pole.
- Choose correct bracket to support the weight of the transformer being mounted. If weight exceeds the mounting bracket capacity, then an overhead platform rack shall be used. Refer to DOH DC 640 for platform rack details. Refer to DOH AP 131 for mounting brackets details.

Table AP 106–3: Weight Limitation of Three-Phase Transformers — Transformer Bracket Mounted on Wood Pole

Transformer Size (kVA) (See Note 3)	Transformer Individual MAX Weight (lb) (See Note 1)	Transformer Weight (Times 3) (lb) (See Note 1)	Transformers & Mounting Bracket Total Weight (See Note 1)
(a)	(b)	(c)	(d)
10	286	858	1,208
15	313	939	1,289
25	450	1,350	1,700
37.5	500	1,500	1,850
50	650	1,950	2,300
75	1,000	3,000	3,350
100	1,300	3,900	4,250
167	1,500	4,500	4,850

= For Reference Only

Note(s):

1. A pole-load calculation must be performed whenever any equipment 200 lb or greater is installed on a wood pole.
2. If a combination of three transformers are used (for example: 2 - 50 kVA and 1 - 100 kVA) which are not shown on this table, add the total weight of the transformers using columns (a) and (b) to determine total weight. Round up to the nearest transformer weight shown in column (d).
3. Transformers (10 kVA and 15 kVA) are not available and not approved for use on new installations or replacements.
4. Choose correct bracket to support the weight of three single-phase transformers. If weight exceeds the mounting bracket capacity, then an overhead platform rack shall be used. See DC 640 for platform rack details.
5. See AP 131 for mounting bracket details.
6. Transformer weights are for 4 kV, 12 kV, and 16 kV, 120/240 and 277/460 V transformers only. For 33 kV primary or above 600 V secondary voltages, contact engineering.

Scope AP 106.2 Transformer Extension Bracket

Figure AP 106-2: Transformer Extension Bracket

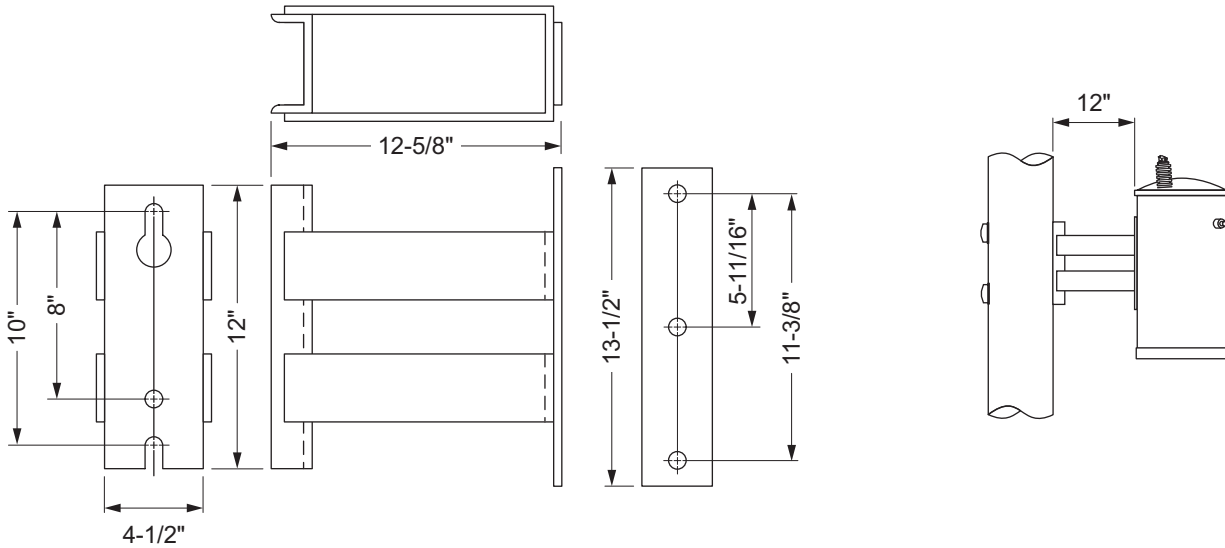

Note(s):

1. The bracket (SAP 10067312) is designed to provide a transformer approximately 12 inches of additional clearance from the pole. It allows mounting a transformer on a switch pole without having to relocate the standard fiberglass operation rod. The switch rod is installed in the center of the extension bracket. Any transformer (1,000 pounds maximum) using 1 OR 2 (11-1/4 inch) mounting brackets may be installed on the extension bracket.

AP 106	Transformer Polemounting and Weight Limitations	Approved by: 
Sheet 6 of 6	What's Changed?	Effective Date:
DOH		01-25-2019

AP 300 Pole-Top Gang-Operated Switches

Scope AP 300.1 Pole-Top Gang-Operated Switches Application

1.0 General Information

1.1 The preferred single-arm, horizontal-mounted, gang-operated overhead switch for 4 kV, 12 kV, and 16 kV systems is the 600 A inverted Omni-Rupter[®] load-break switch. Refer to DDS-10 for criteria to determine appropriate Omni-Rupter[®] construction method. The preferred single-arm, horizontal-mounted, gang-operated overhead switch for 25 kV and 33 kV systems is the 600 A inverted Alduti-Rupter[®] load-break switch.

Per Power Line Fire Prevention Field Guide (published by the California Department of Forestry and Fire Protection), the Omni-Rupter[®] switch is considered exempt equipment. Fire clearing (weed abatement) is not required when the Omni-Rupter[®] switch is installed in fire hazard areas. However, the Alduti-Rupter[®] switch is considered nonexempt equipment. Therefore, fire clearing is required when the Alduti-Rupter[®] switch is installed in fire hazard areas. Refer to the DOM Manual, Section IM-6 for fire clearing procedures.

Omni-Rupter[®] and Alduti-Rupter[®] switches have a maximum dead-ending capability of 8,000 lb per conductor where equal pull-off forces are applied to both sides of the switch and a rating of 700 lb per conductor where pull-off forces are applied to only one side of the switch. Refer to the table titled "Conductor Dead-End Tension" in DDS-10. The Omni-Rupter[®] and/or Alduti-Rupter[®] switches have the following applications:

- A. May be used on riser poles to switch underground systems in place of underground switches (Omni-Rupter[®] Only)
- B. Ability to switch ferroresonant cable and transformer systems
- C. Ability to switch at system parallel locations
- D. Inverted Omni-Rupter[®] switch to be used for wildlife-safe construction.
- E. The Omni-Rupter[®] or Alduti-Rupter[®] switch should not be installed to switch a capacitor bank.

1.2 The Omni-Rupter[®] can switch unloaded cable charging current up to 26 A, approximately equivalent to switching up to 10 miles of unloaded underground 1000 kcmil cable. The Omni-Rupter[®] can switch unloaded overhead line charging current up to 10 A.

1.3 The Alduti-Rupter[®] can switch up to 2.5 A of line charging current.

Approved by: <i>ajf</i>	Pole-Top Gang-Operated Switches	AP 300	
Effective Date: 01-25-2019	What's Changed?	Sheet 1 of 18	DOH

- 1.4 The 600 A line torsion disconnect switches (KPF) are to be generally used for pole top applications when an Omni-Rupter® or Alduti-Rupter® is not applicable. Generally, the 23 kV class switch (two bells) should be used on 12 kV systems. In “A” contamination areas on 12 kV systems and for all 16 kV to 33 kV systems, the 34.5 class switch (three bells) is to be used. These switches are designed for paralleling and sectionalizing only; **they are not designed to interrupt load**. All old 400 A switches removed from service should be salvaged.
- 1.5 All KPF switches used on the 33 kV system should be installed with the quick-break attachment. All existing switches, without this attachment, should have quick breaks installed as soon as practical.
- 1.6 All KPF switches are automatically supplied with standard bell cranks, but 90-degree or 180-degree bell cranks may be purchased separately for any Type “A,” “U,” or “LA” switch. (see [AP 320](#)).
- 1.7 Dead-end type insulators (SAP 10116431) must be installed between the switch dead-end point and dead-end shoe (see [Figure AP 300–1 \[Sheet 2\]](#) for all new KPF Switch installations). Likewise, dead-end type insulators must be installed on existing KPF Switch installations with overheating problems caused by the creation of secondary current path through the switch moving arm as the impedance at the connection between the primary circuit and disconnect switch tap increases. The secondary current path results in the heating of the clevis connection of the dead-end shoe, leading to mechanical failure.

Figure AP 300–1: Polymer Insulator for KPF Switch Installation

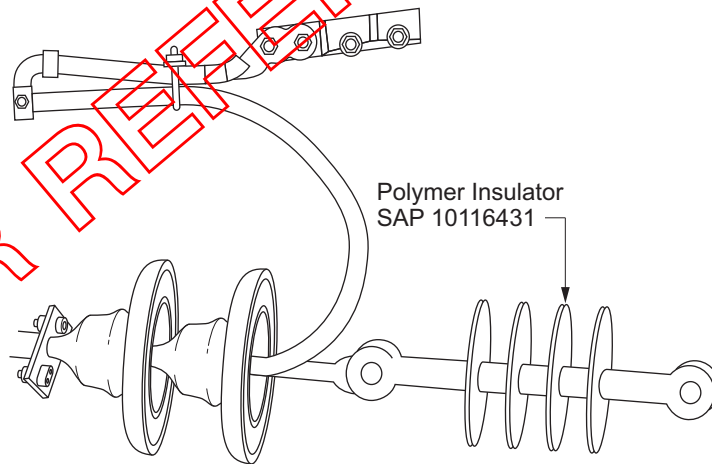

FOR REFERENCE ONLY

- 1.8 The bell crank provided on the previous style upright Omni-Rupter® switches, where the operating rod is oriented on the side of the pole (see Figure AP 300-7), can be replaced with the new toggle mechanism bell crank (SAP 10107174). The toggle mechanism bell crank orients the operating rod on the same face of the pole as the cross-arm of the switch (see Figure AP 300-2).

Figure AP 300-2: Toggle Mechanism Bell Crank

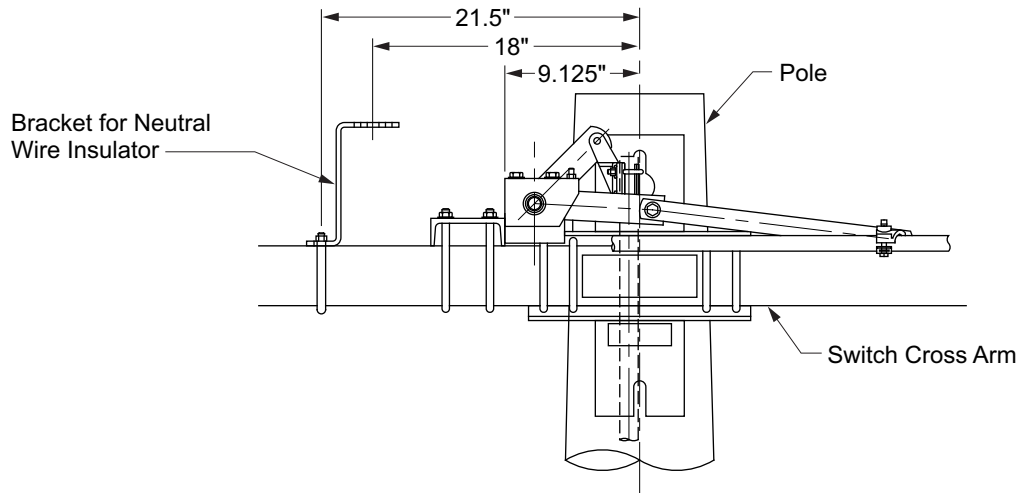

- 1.9 All Omni-Rupter® switches used as bypass switches for Automation Recloser's shall have the toggle mechanism bell crank. (see Section 1.8 for retrofit materials).
- 1.10 For damaged R4-type interrupters, use SAP 10183495 for Omni-Rupter® interrupter replacement. Follow manufacturer's instructions provided with the interrupter. Previous Omni-Rupter® R1, R2, and R3-type interrupters with damage can no longer be replaced, contact Distribution Apparatus and Standards Engineering.

Figure AP 300-3: R4-Type Interrupter for Omni-Rupter® Switch

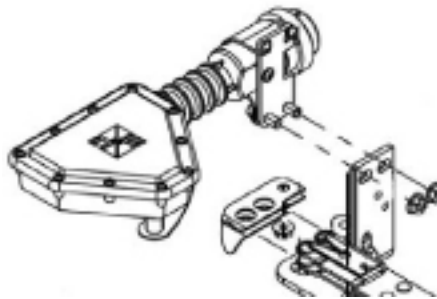

- 1.11 Additional and replacement rod guide assemblies (SAP 10068679) are available. The standard Omni-Rupter® switches are provided with three (3) rod guide assemblies.

Approved by: 	Pole-Top Gang-Operated Switches	AP 300
Effective Date: 01-25-2019	What's Changed?	Sheet 3 of 18 DOH

1.12 The steel interphase rod on the existing vertical Omni-Rupter® switch should be retrofitted and replaced with the fiberglass interphase rod by using the retrofit kit (SAP 10177244). (see Figure AP 300-4 (Sheet 4)).



NOTE
The steel interphase rod should be replaced in conjunction with other work being performed on the pole. Appropriate opportunities would include installing, removing, or reconductoring primary conductors, constructing a new circuit, constructing an underground primary riser, automating or adding a switch to the pole, or installing an overhead transformer or capacitor bank.

Figure AP 300-4: Vertical Omni-Rupter® Switch

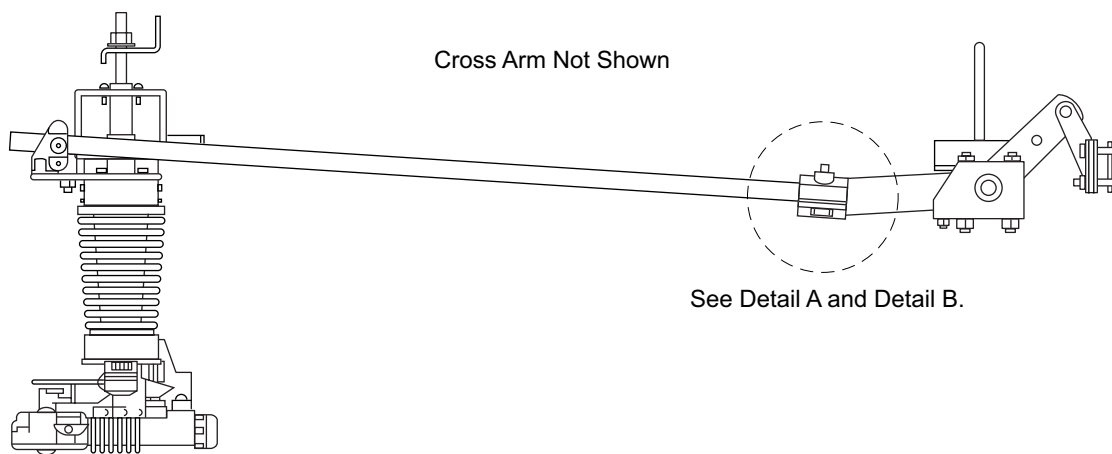

Detail A

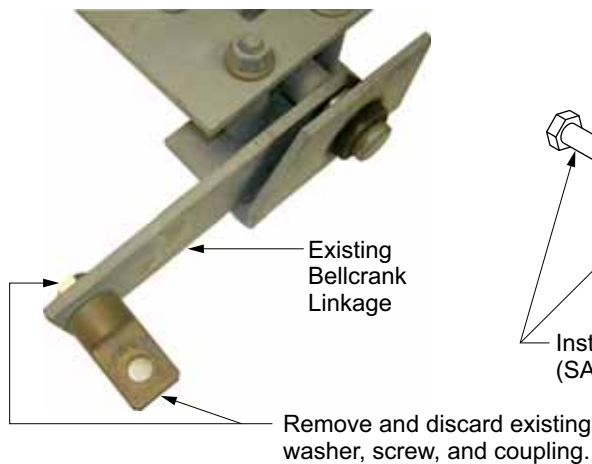

Detail B

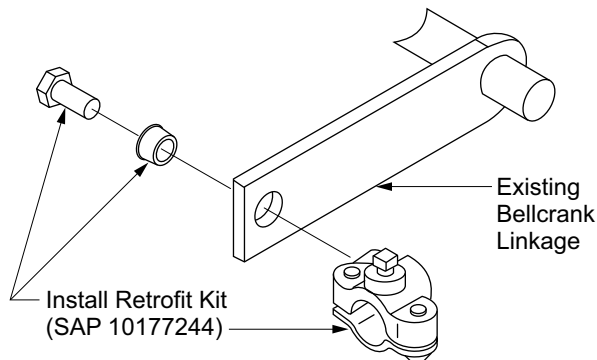

1.13 For replacement Omni-Rupter® handle, use SAP 10107150.

AP 300	Pole-Top Gang-Operated Switches	Approved by: <i>ajf</i>
	Sheet 4 of 18	Effective Date: 01-25-2019
DOH	What's Changed?	

2.0 Standard Crossarm Construction

2.1 Single-arm

- A. Horizontal type Omni-Rupter® and single-arm horizontal type Alduti-Rupter® switches are to be used wherever possible as they are the most economical to install. All other types are designed for special applications. Omni-Rupter® switches can also be used on riser poles to switch underground systems. See [AP 336](#) for typical Omni-Rupter® and [AP 338](#) for typical Alduti-Rupter® switch construction.
- B. Omni-Rupter® load-break switches may be installed in the line for horizontal construction. They can also be installed under a double-line arm for Grade “A” crossings, line angle poles, or on riser poles to switch underground systems.
- C. When utilizing below line arm construction on inverted Omni-Rupter® switches, the Hughes Adapter shall be installed to prevent contact between the jumper wire and interphase rod, and between jumper wires. See [AP 336.2](#) for ordering information and typical Inverted Omni-Rupter® switch below line-arm construction using the Hughes Adapter, and [AP 336.1](#) for typical direct dead-end to switch crossarm construction methods for Inverted Omni-Rupter®.
- D. For retrofit of an existing inverted Omni-Rupter® switch utilizing below line arm construction. Refer to DOM SW-2 for retrofit criteria details.
- E. Horizontal inverted Omni-Rupter® switches are to be installed for wildlife-safe construction (see [DC 535](#) for additional details).

F. KPF Switches are designed for proper operation under line tension and should be installed in the line for vertical construction.

2.2 The Double-Arm KPF Switch can be used where Grade “A” crossings are required with vertical construction. It can also be used for horizontal construction when adequate pole height is not available to install an Omni-Rupter® under a double-line arm. The double-arm KPF does not require tension on either side for satisfactory operation. The stationary side may be used for slack-span dead-ends or underground dips (see [Figure AP 300–11 \(Sheet 7\)](#)).

2.3 The Line-Angle KPF Switch should be installed where the maximum allowable line or elevation angle exceeds those specified for the other types and where there is not adequate pole height to install an Omni-Rupter® under an angle-line arm. The maximum angle permitted for the Line-Angle KPF is 45 degrees. This switch can also be used for underground dips or slack-span application without modification as it is designed for use with tension on the rotating side only (see [Figure AP 300–12 \(Sheet 7\)](#)).

2.4 Tilting insulator type switches are FOR REFERENCE ONLY (see [AP 310](#)).

Approved by:	Pole-Top Gang-Operated Switches	AP 300
Effective Date:	What's Changed?	Sheet 5 of 18
01-25-2019		DOH

Scope AP 300.2 Pole Top Gang-Operated Switches

Figure AP 300-5: Omni-Rupter[®]-Inverted Horizontal-Single (Side-Operating Rod)

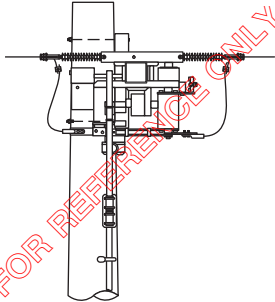

Figure AP 300-6: 17 kV Omni-Rupter[®]-Inverted Horizontal-Single Arm (Face-Operating Rod)

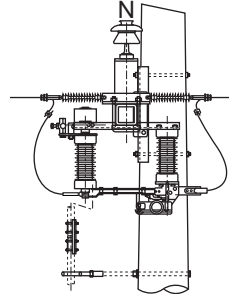

Figure AP 300-7: 17 kV Omni-Rupter[®]-Upright Horizontal-Single Arm (Side-Operating Rod)

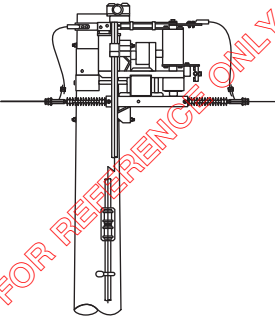

Figure AP 300-8: 17 kV Omni-Rupter[®]-Upright Horizontal-Single Arm (Face-Operating Rod)

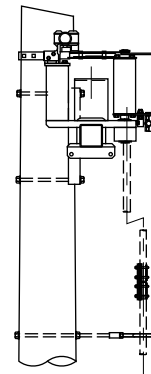

Figure AP 300-9: 38 kV Alduti-Rupter[®]-Upright Horizontal-Single Arm

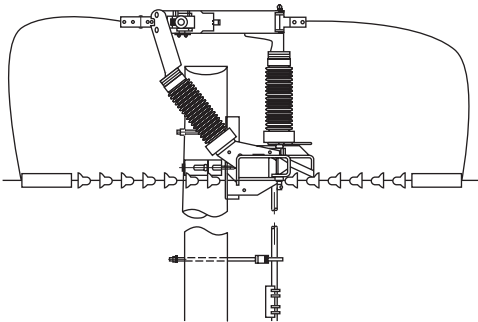
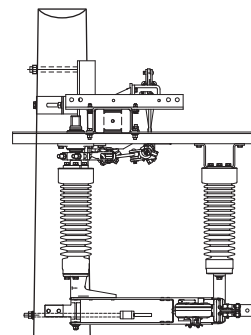
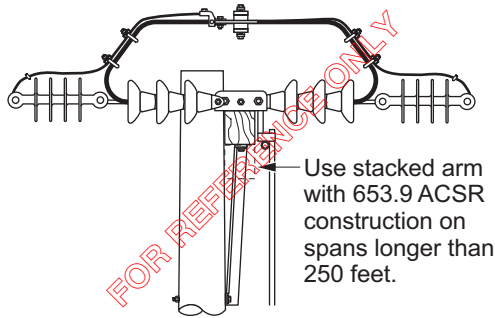

Figure AP 300-10: 38 kV Alduti-Rupter[®]-Inverted Horizontal-Single Wildlife-Safe



**Figure AP 300–11: Horizontal-Single Arm
Vertical-Single Arm**



**Figure AP 300–12: Horizontal-Double
Arm-Slack Side Vertical-Double
Arm-Slack Side**

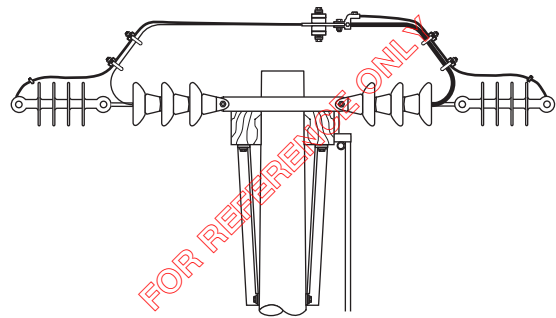

**Figure AP 300–13: Horizontal-Double
Arm-Line Angle**

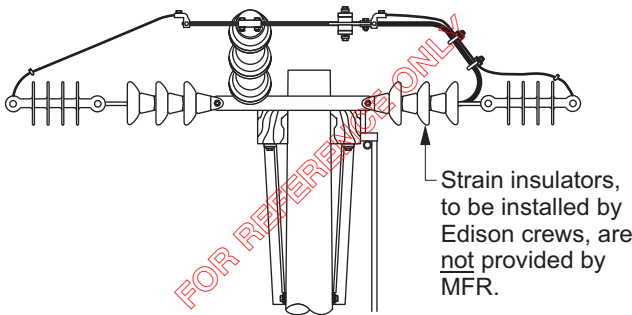

**Figure AP 300–14: Vertical-Single
Circle Line Angle “KPF Type W”**

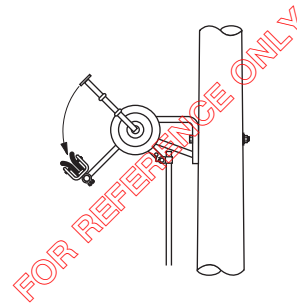

**Figure AP 300–15: Vertical-Double Circle
“KPF Type W”**

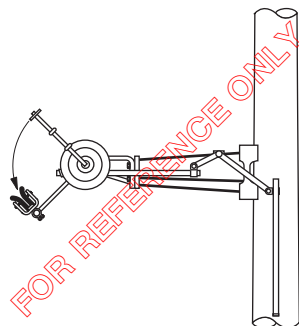

**Figure AP 300–16: Triangular Mounting
“KPF Type W”**

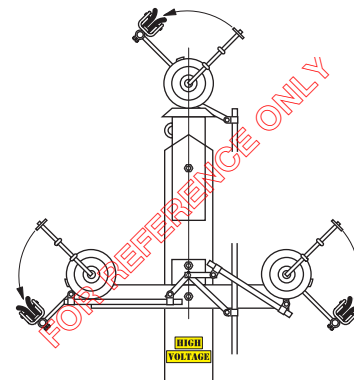

Approved by:

ajt

Pole-Top Gang-Operated Switches

AP 300

Effective Date:
01-25-2019

What's Changed?

Sheet 7 of 18

DOH

Figure AP 300-17: 17 kV Omni-Rupter®-Inverted Vertical-Single Arm (Face-Operating Rod)

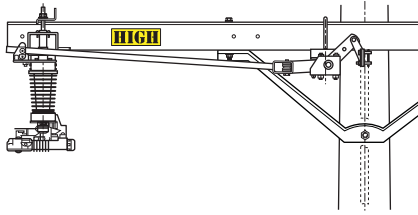

Figure AP 300-18: 17 kV Omni-Rupter® Horizontal-Side Arm-DIP Switch (Side-Operating Rod)

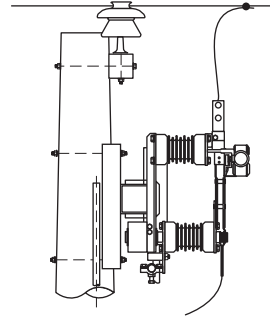
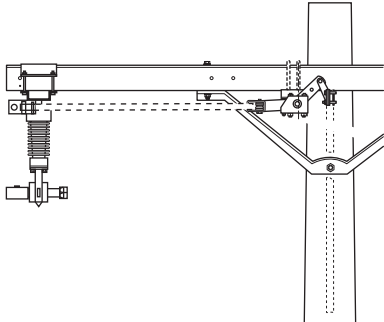
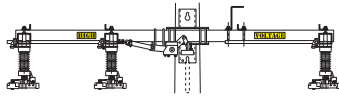
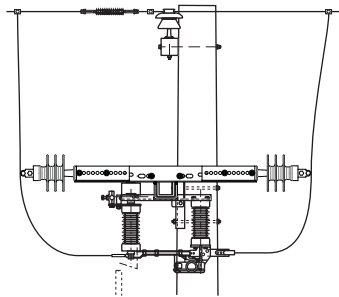
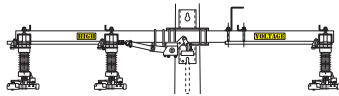
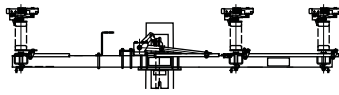
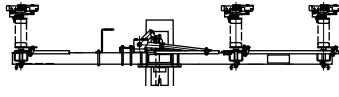
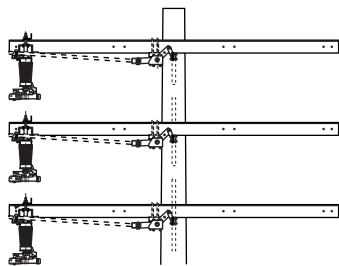

Figure AP 300-19: 38 kV Adulti-Rupter® Inverted Vertical-Double Arm (Face-Operating Rod)



Scope AP 300.3 Pole-Top Gang-Operated Switches Application Table

Table AP 300-1: Pole-Top Gang-Operated Switches Application Table

Circuit Voltage	Switch Rating		Switch Type	Switch Application	Figure Reference	SAP
	kV	A				
4 kV 12 kV 16 kV	17	600	Omni-Rupter [®] (see Note 4 & 5)	Horizontal—Single Arm— Inverted for Dead-End onto Switch Construction	 DOH AP 336-1	10107145
			Omni-Rupter [®] (see Note 4, 5, & 7)	Horizontal—Single Arm— Inverted for Below Line Arm Construction, Includes Hughes Adapter	 (Side View) DOH AP 336-2	10107145
			Omni-Rupter [®] (see Note 4 & 5)	Horizontal-Single 12 foot Arm Inverted Switch for transmission poles or when additional climbing clearance is needed for congested distribution poles.	 DOH AP 300-6	10107186
			Omni-Rupter [®] (see Note 4)	Horizontal-Single Arm-Upright	 DOH AP 336-8	10107118
			Omni-Rupter [®] (see Note 4 & 5)	Horizontal-Single 12 foot Arm-Upright Switch-Transmission Pole Only	 DOH AP 300-8	10107159
			Omni-Rupter [®]	Vertical-Single Arm-Mounted Inverted	 DOH AP 336-5	10107158

Approved by:

ajf

Pole-Top Gang-Operated Switches

Effective Date:
01-25-2019

What's Changed? Revised Transmission Pole style switch application description.

AP 300

Sheet 9 of 18

DOH

Table AP 300-1: Pole-Top Gang-Operated Switches Application Table (Continued)





Circuit Voltage	Switch Rating		Switch Type	Switch Application	Figure Reference	SAP
	kV	A				
4 kV 12 kV 16 kV	17	600	Omni-Rupter®	Horizontal-Side Arm-Primary Overhead to Underground DIP	 DOH AP 300-18	10107119
4 kV	4	600	Omni-Rupter®	Horizontal-Single Arm-Upright 4 Pole Unit for 4 kV Isolated Neutral System Only	 DOH AP 300-8	10107147
			Omni-Rupter® (see Note 4 & 5)	Horizontal-Single Arm-Inverted 4 Pole Unit for 4 kV Isolated Neutral System Only	 DOH AP 300-6	10174421
			Omni-Rupter®	Horizontal-Single Arm-Upright w/ Neutral at End of Crossarm	 DOH AP 300-8	10183278
			Omni-Rupter® (see Note 4 & 5)	Horizontal-Single Arm-Inverted w/ Neutral at End of Crossarm	 DOH AP 300-6	10172425
			Omni-Rupter® (see Note 4 & 5)	Horizontal-Single Arm-Inverted w/ Neutral at End of Crossarm Coastal	 DOH AP 300-6	10173809

Table AP 300-1: Pole-Top Gang-Operated Switches Application Table (Continued)

Circuit Voltage	Switch Rating		Switch Type	Switch Application	Figure Reference	SAP
	kV	A				
4 kV 12 kV 16 kV Contamination Area "A" Only	17	600	Omni-Rupter® (see Note 4 & 5)	Horizontal-Single Arm-Inverted Coastal	 DOH AP 336-1	10172162
			Omni-Rupter®	Vertical-Single Arm-Mounted Inverted Coastal	 DOH AP 336-5	10183277
			Omni-Rupter®	Horizontal-Single Arm-Upright Coastal	 DOH AP 336-8	10107190

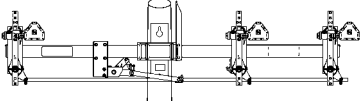
Approved by:

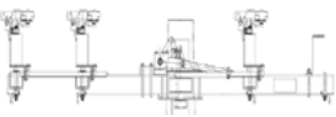
ajf

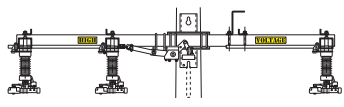
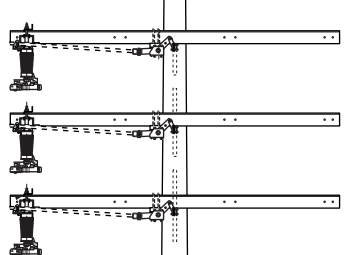
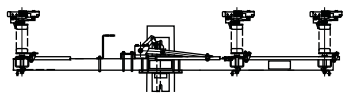
Pole-Top Gang-Operated Switches

AP 300

Effective Date:



01-25-2019

What's Changed?

Sheet 11 of 18

DOH

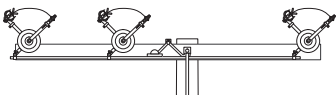
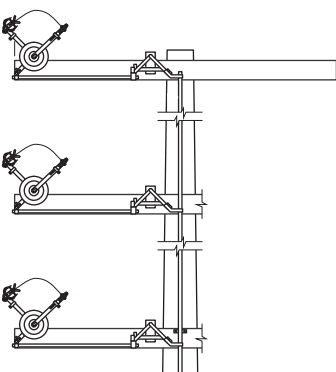
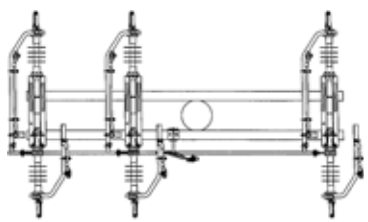
Table AP 300-1: Pole-Top Gang-Operated Switches Application Table (Continued)

Circuit Voltage	Switch Rating		Switch Type	Switch Application	Figure Reference	SAP
	kV	A				
12 kV	23	600	KPF (A-202)	Horizontal-Single Arm (Key 06)	 DOH AP 312-1	10107029
			KPF (A-202)	Vertical-Single Arm-Mounted Preferred (Key 06)	 DOH AP 314-1	10107030
			KPF (U-2)	Horizontal-Double Arm-Slack Side (Key 06)	 DOH AP 300-12	10107042
			KPF (U-2)	Vertical-Double Arm-Slack Side (Key 06)	 DOH AP 300-12	10107044

AP 300

Pole-Top Gang-Operated Switches

Approved by:

ajf

Sheet 12 of 18

What's Changed?

Effective Date:

DOH

01-25-2019

Table AP 300-1: Pole-Top Gang-Operated Switches Application Table (Continued)

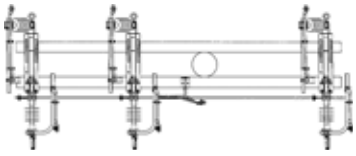
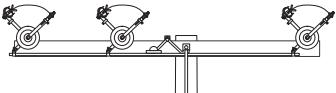
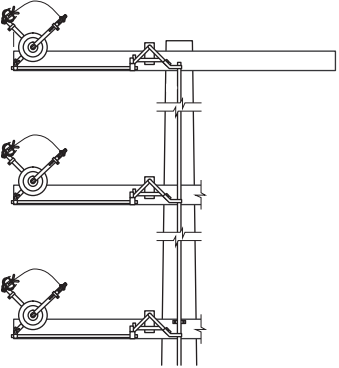
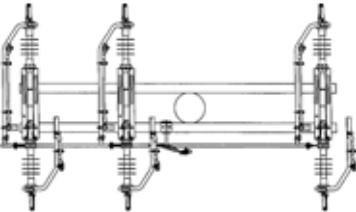
Circuit Voltage	Switch Rating		Switch Type	Switch Application	Figure Reference	SAP
	kV	A				
12 kV	23	600	KPF (LA-202)	Horizontal-Double Arm-Line Angle (Key 06)	 DOH AP 300-13	10107041
			Switch Type KPF (A-202)	Horizontal-Single Arm-Preferred (Key 06)	 DOH AP 300-11	10107031
			KPF (A-202)	Vertical-Single Arm-Mounted Preferred (Key 06)	 DOH AP 300-11	10107032
			KPF (U-2)	Horizontal-Double Arm-Slack Side (Key 06)	 (Plan View) DOH AP 300-12	10107043

Approved by:

ajf

Pole-Top Gang-Operated Switches

AP 300

Sheet 13 of 18

Effective Date:
01-25-2019

What's Changed?

DOH

Table AP 300–1: Pole-Top Gang-Operated Switches Application Table (Continued)

Circuit Voltage	Switch Rating		Switch Type	Switch Application	Figure Reference	SAP
	kV	A				
12 kV	23	600	KPF (U-2)	Vertical-Double Arm-Slack Side (Key 06)	 <p>(Side view) DOH AP 300-12</p>	10107045
12 kV 16 kV Automated	17	600	Omni-Rupter® (see Note 3, 4, 5, & 6)	Horizontal-Single Arm-Inverted for Automation	 <p>DOH AP 337-2</p>	10107075
			Omni-Rupter® (see Note 3, 4, 5, & 6)	Horizontal-Single Arm-Upright for Automation	 <p>DOH AP 337-5</p>	10107080
			Omni-Rupter®	Vertical-Single Arm – Mounted Inverted for Automation	 <p>DOH AP 337-4</p>	10107191

Table AP 300–1: Pole-Top Gang-Operated Switches Application Table (Continued)

Circuit Voltage	Switch Rating		Switch Type	Switch Application	Figure Reference	SAP
	kV	A				
33 kV	38	600	Alduti-Rupter®	Horizontal-Single Arm-Upright Switches	 DOH AP 338-3	10107431
			Alduti-Rupter®	Horizontal-Single Arm-Inverted Switches	 DOH AP 338-1	10107356
			Alduti-Rupter®	Vertical-Double Arm-Mounted Inverted Switches	 DOH AP 338-2	10172190

Approved by:

ajf

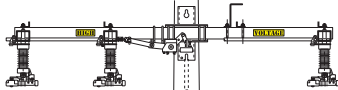
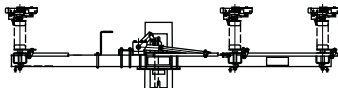
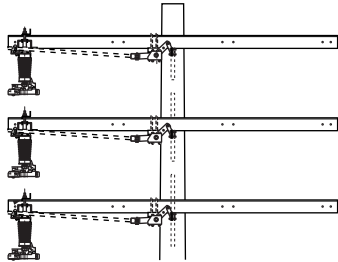
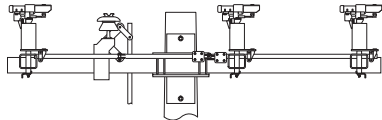
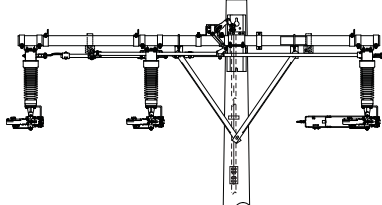
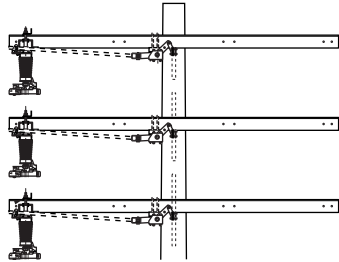
Pole-Top Gang-Operated Switches

AP 300

Effective Date:

01-25-2019

What's Changed?

Sheet 15 of 18

DOH

Table AP 300-1: Pole-Top Gang-Operated Switches Application Table (Continued)

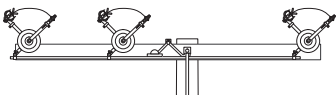
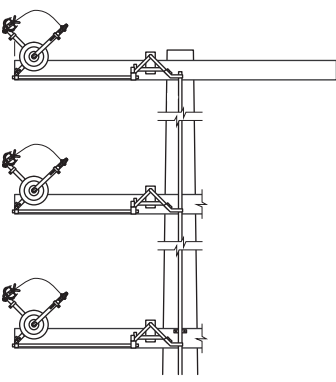
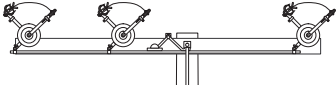
Circuit Voltage	Switch Rating		Switch Type	Switch Application	Figure Reference	SAP
	kV	A				
16 kV 24.9 kV 33 kV 12 kV Contamination Area "A" Only	34.5	600	KPF (A-202)	Horizontal-Single Arm-Preferred 33 kV Only (Key 06)	 DOH AP 300-11	10107035
			KPF (A-202)	Vertical-Single Arm Mounted- Preferred (Key 06)	 DOH AP 300-11	10107037
			KPF (U-2)	Horizontal-Double Arm-Slack Side (Key 06)	 DOH AP 300-12	10107048

AP 300

Pole-Top Gang-Operated Switches

Approved by:

ajf

Sheet 16 of 18

What's Changed?

Effective Date:

DOH

01-25-2019

Table AP 300-1: Pole-Top Gang-Operated Switches Application Table (Continued)

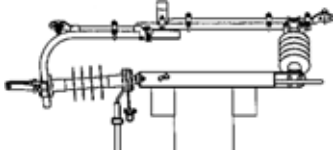
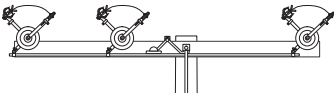
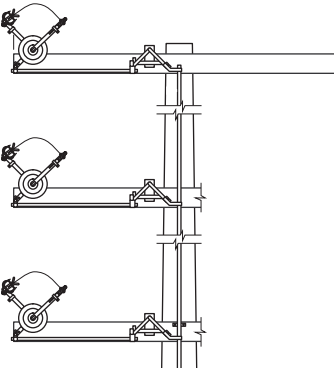
Circuit Voltage	Switch Rating		Switch Type	Switch Application	Figure Reference	SAP	
	kV	A					
16 kV 24.9 kV 33 kV 12 kV Contamination Area "A" Only	34.5	600	KPF (U-2)	Vertical Mount-Double Arm-Slack Side (Key 06)	 (Plan view) DOH AP 300-12	10107049	
			KPF (LA -202)	Horizontal-Double Arm-Line Angle (Key 06)	 (Side view) DOH AP 300-13	10107040	
			400	KPF (A-202)	Horizontal-Single Arm-Preferred (Key 06)	 (Plan view) DOH AP 300-11	10107038
				KPF (A-202)	Vertical-Single Arm-Preferred (Key 06)	 DOH AP 300-11	10107039

Approved by:

ajt

Pole-Top Gang-Operated Switches

AP 300

Effective Date:

01-25-2019

What's Changed?

Sheet 17 of 18

DOH

Table AP 300–1: Pole-Top Gang-Operated Switches Application Table (Continued)

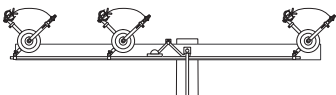
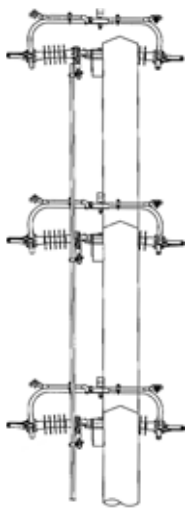
Circuit Voltage	Switch Rating		Switch Type	Switch Application	Figure Reference	SAP
	kV	A				
16 kV 24.9 kV 33 kV 12 kV Contamination Area "A" Only	34.5	400	KPF (U-2)	Horizontal-Double Arm-Slack Side (Key 06)	 DOH AP 300-12	10107046
			KPF (U-2)	Vertical-Double Arm-Slack Side (Key 06)	 DOH AP 300-12	10107047

Note(s):

1. 400 A KPF switches are equipped with 250 kcmil tinned copper leads (0.575 diameter).
2. 600 A KPF switches are equipped with 500 kcmil tinned copper leads (0.855 diameter).
3. All KPF switches are supplied with standard bell cranks. If 90-degrees or 180-degrees bell cranks are required, order separately.
4. The Omni-Rupter® switch can also be installed underneath the line arm because it does not require line tension.
5. Omni-Rupter® switch-inverted configuration, for use in horizontal type wildlife-safe construction.
6. Switches provided for automation are not supplied with manual handles.
7. For new construction, Omni-Rupter® switches mounted below the line arm shall be installed with the Hughes Adapter. Compatible units for Omni-Rupter® below line arm construction include the Hughes Adapter kit.
8. For existing inverted Omni-Rupter® switches mounted below the line arm, refer to DOM SW-2 for Hughes Adapter retrofit criteria.
9. Distribution construction shall contact the Distribution Automation Hotline when installing, relocating, or removing automated equipment at 714-285-4325. Hours: Mon–Fri 7 a.m.–4 p.m. Available after hours/weekends upon request.

= For Reference Only

AP 337 Automated 600 A, 17 kV Omni-Rupter Load-Break Switches

Scope AP 337.1 Automation Equipment Information for 600 A, 17 kV Omni-Rupter Load-Break Switches

Figure AP 337–1: Not Over-Toggled Bell Crank Rocker Arm and Switch Rod

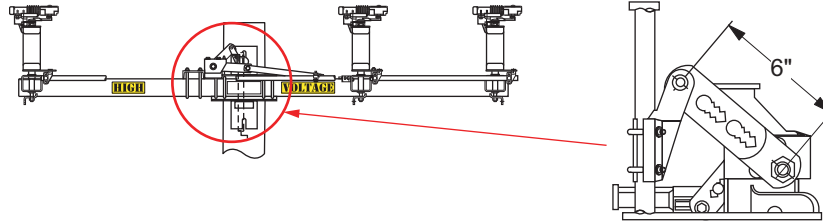

Note(s):

1. See [AP 360](#) for Cleaveland/Price[®] Automated Distribution Motor Operated (ADMO) and joint pole PVC operating rod cover installation.
2. See [AP 336](#) for Omni-Rupter switch and operating rod installation details.
3. See [AP 363](#) for 12/16 kV to 120 V, Dry Type voltage transformer installation details.
4. Verify the switch rocker arm is adjusted to 6 inches (older design) or to its respective hole position (newer design), as shown in [Figure AP 337–1](#).
5. Verify that the ADMO stroke is set to 9-1/8-inches (Hole 2). Refer to DOM SW-11 Section 4.3 for details on stroke adjustment.
6. Verify switch blades are fully closed and the bell crank in over-toggled when installing fiberglass rod assembly.
7. Distribution construction shall contact the Distribution Automation Hotline when installing, relocating, or removing automated equipment at 714-285-4325. Hours: Mon–Fri 7 a.m.–4 p.m. Available after hours/weekends upon request.

Table AP 337–1: SAP Number

Description	SAP
ADMO Control	10107141
12/16 kV to 120 V, 0.5 kVA, Dry Type VT (Vented)	10105091
VT Mounting Bracket	10104923
VT Mounting Bracket Extension	10067312
CLD for 12/16 kV VT	10159438
Fiberglass Rod 1" Diameter	10107285
Dead End Suspension Insulator 25 kV	10116332
33 kV	10116432
Butt Splices (for 120 VAC connections)	10111371

Table AP 337–2: ADMO Mounting Height Criteria

Preferred	8' above ground
Higher Than 8 Feet	<p>At a specified height, as determined by the planner due to the following conditions:</p> <ul style="list-style-type: none"> • Ability to work over fence with bucket • Bus Stop • Communications obstacles • Fences and walls • Parking area • Slopes • Traffic — vehicle and pedestrian • Trees and shrubs <p>Examples:</p> <ul style="list-style-type: none"> • 6' below communication cable (usually 12'–15' above ground) • 4' below communication cable with no junction box (usually 14'–17' above ground) • 13'-6" above ground level to clear truck traffic <p>Note: Contact the responsible Apparatus Foreman if the control is planned to be mounted above 8'.</p>
Lower (4-8 Feet)	<p>4' minimum if the following conditions are met:</p> <ul style="list-style-type: none"> • Away from obstacles - fences and walls • Away from parking area • Away from traffic signals • Away from traffic - vehicle and pedestrian • Rural areas • SCE Substation and locked fence areas

AP 337

Automated 600 A, 17 kV Omni-Rupter Load-Break Switches

Approved by:



Sheet 2 of 15

What's Changed?

Effective Date:

DOH

01-25-2019

Scope AP 337.2 Automated Horizontal Inverted Omni-Rupter Switch, Line Dead-Ended Directly to Switch

Figure AP 337-2: Automated Horizontal Inverted Omni-Rupter Switch, Line Dead-Ended Directly to Switch

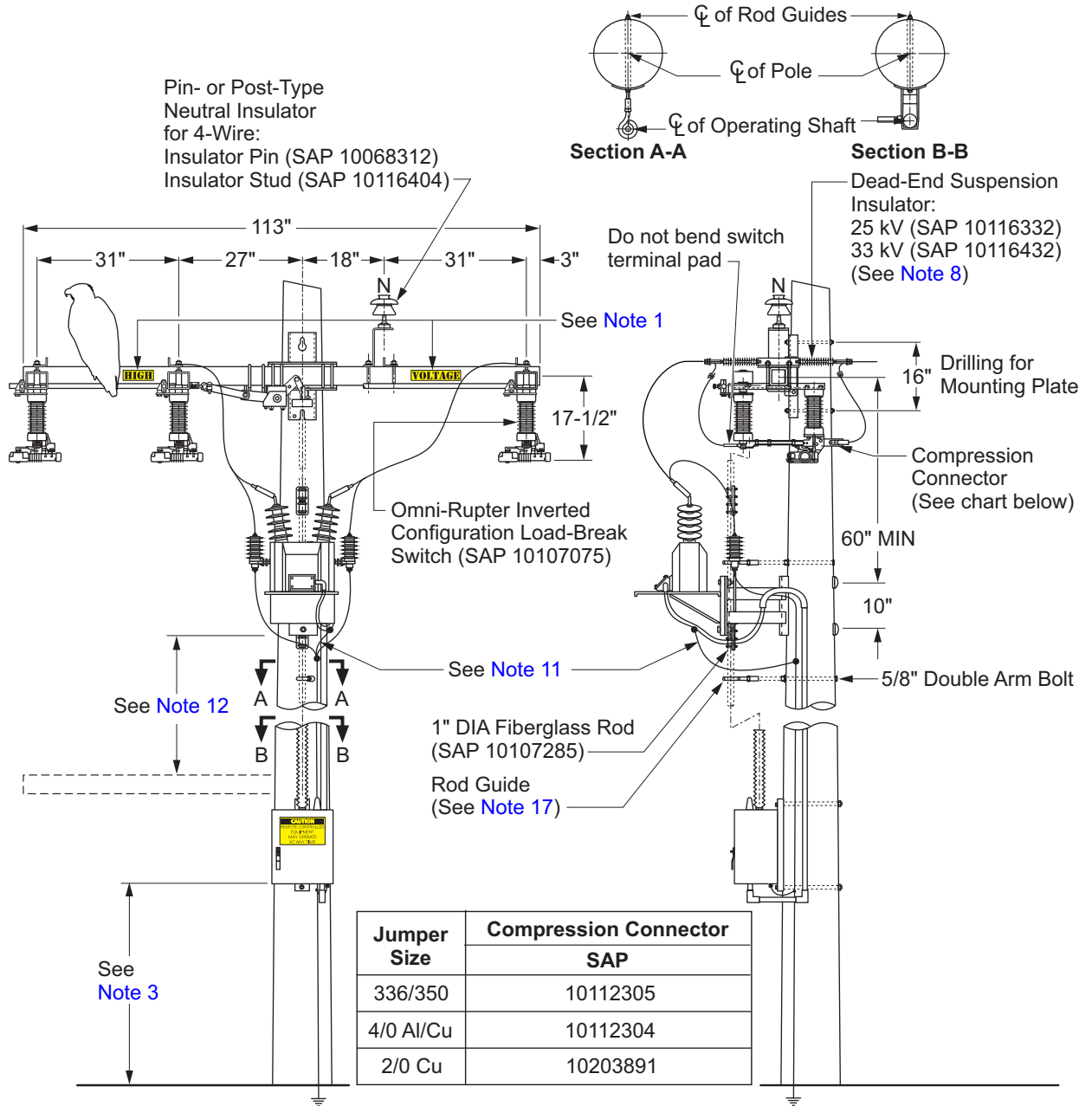

Approved by:

ajf

Automated 600 A, 17 kV Omni-Rupter Load-Break Switches

AP 337

Effective Date:
01-25-2019

What's Changed?

Sheet 3 of 15

DOH

Note(s):

1. See [PO 120](#) for HIGH VOLTAGE sign installation requirements.
2. See [AP 336](#) for Omni-Rupter switch and operating rod installation details.
3. See [Table AP 337-2](#) for ADMO mounting height criteria.
4. See [AP 360](#) for Cleveland Price Automated Motor Operator (ADMO) and joint pole PVC operating rod cover installation.
5. See [AP 363](#) for dry type potential transformer installation details.
6. See [CO 217](#) for Dead Ending and Isolators.
7. Verify switch blades are fully closed and the bell crank over-toggled when installing rod/handle assembly.
8. Do not install 15 kV dead-end suspension insulators; use 25 kV or 33 kV dead-ends.
9. Verify that the switch rocker arm is adjusted to 6 inches (older design) or to its respective hole position (newer design) as shown in [Figure AP 337-1](#).
10. Verify that the ADMO stroke is set to 9-1/8-inches (Hole 2). Refer to DOM SW-11 Section 4.3 for details on stroke adjustment.
11. Surge arrestors, potential transformers secondary neutral, and the ADMO cabinet shall be connected to a common equipment ground to minimize any potential ground differences between the equipment (see [GR 105](#) and [Scope AP 337.5](#)).
12. For secondary maintain a minimum clearance of 10 inches from top of insulator to lowest point of PT bracket. For under built, maintain a minimum clearance of 3 feet from middle of crossarm to lowest point of PT bracket.
13. Use insulated butt-splices (SAP 10111371) to connect the secondary PT, black and white wires (120 VAC) inside the ADMO.
14. Per [DC 535](#), Wildlife Protection shall be constructed and installed as applicable for insulators, taps, leads, arresters, cable terminations, and equipment bushings.
15. Construction crew shall coordinate the installation of new and updated RCS with Distribution Automation Engineering in order to perform an end point test (EPT) and commission unit in service.
16. When primary neutral ground exist on the same pole, it shall be a separately installed ground from that of the common equipment ground.
17. The uppermost rod guide shall be located 5 feet to 6 feet below the underside of the switch crossarm. The lowest rod guide shall be located 6'-11" above the switch handle pivot. Distribute additional rod guides uniformly at 6 feet maximum and maintain at least 10 inches clearance between the upper edge of each rod guide and the lower edge of the straight coupler.

AP 337	Automated 600 A, 17 kV Omni-Rupter Load-Break Switches	Approved by: <i>ajf</i>
Sheet 4 of 15	What's Changed?	Effective Date: 01-25-2019
DOH		

Scope AP 337.3 Automated Vertical Inverted Omni-Rupter Switch

Figure AP 337-3: Automated Vertical Inverted Omni-Rupter Switch

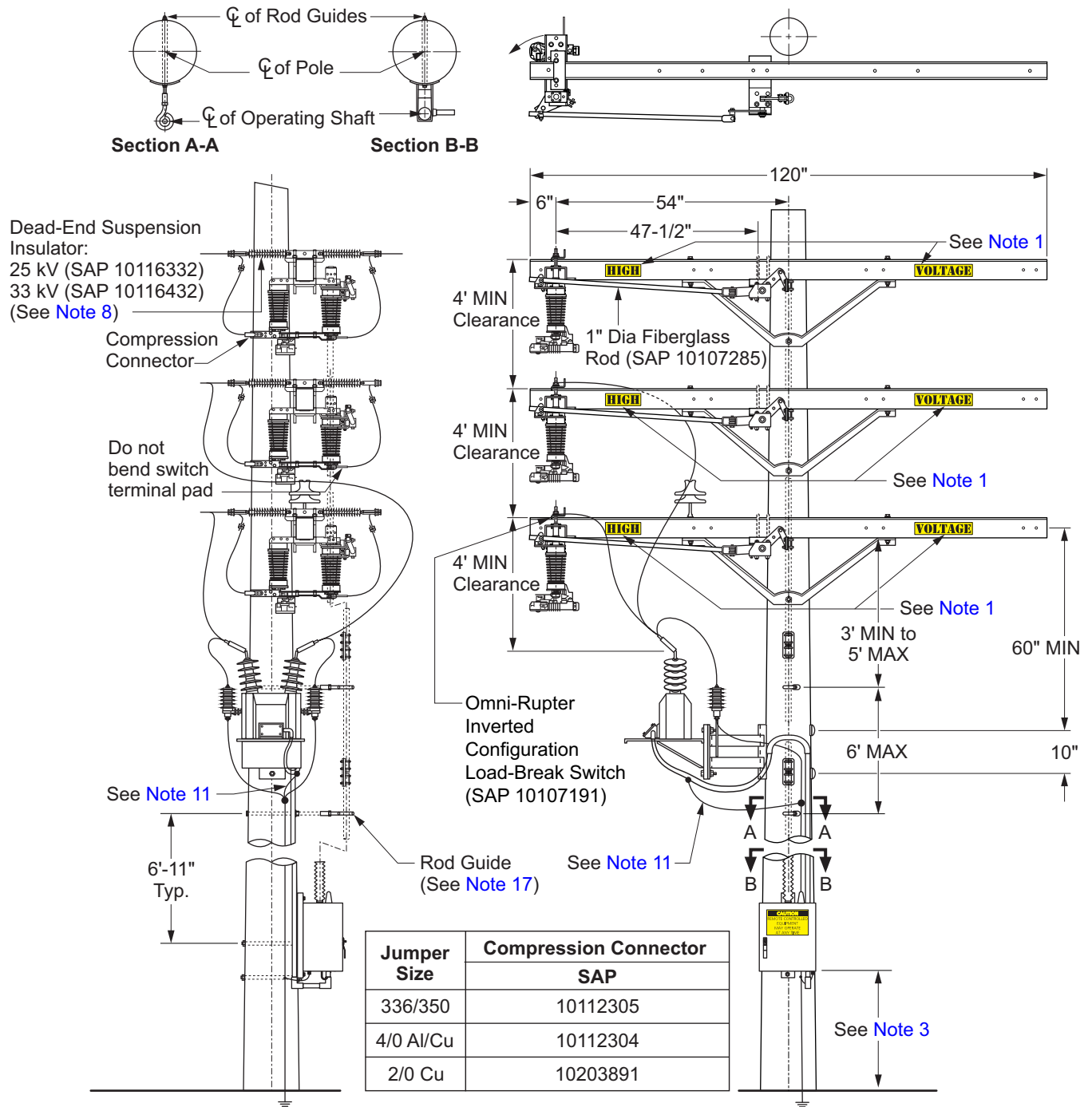

Approved by:

ajf

Automated 600 A, 17 kV Omni-Rupter Load-Break Switches

AP 337

Effective Date:
01-25-2019

What's Changed?

Sheet 5 of 15

DOH

Note(s):

1. See [PO 120](#) for HIGH VOLTAGE sign installation requirements.
2. See [AP 336](#) for Omni-Rupter switch and operating rod installation details.
3. See [Table AP 337-2](#) for ADMO mounting height criteria.
4. See [AP 360](#) for Cleveland Price Automated Motor Operator (ADMO) and joint pole PVC operating rod cover installation.
5. See [AP 363](#) for dry type potential transformer installation details.
6. See [CO 217](#) for Dead Ending and Isolators.
7. Verify switch blades are fully closed and the bell crank over-toggled when installing rod/handle assembly.
8. Do not install 15 kV dead-end suspension insulators; use 25 kV or 33 kV dead-ends.
9. Verify that the switch rocker arm is adjusted to 6 inches (older design) or to its respective hole position (newer design) as shown in [Figure AP 337-1](#).
10. Verify that the ADMO stroke is set to 9-1/8-inches (Hole 2). Refer to DOM SW-11 Section 4.3 for details on stroke adjustment.
11. Surge arrestors, potential transformers secondary neutral, and the ADMO cabinet shall be connected to a common equipment ground to minimize any potential ground differences between the equipment (see [GR 105](#) and [Scope AP 337.5](#)).
12. For secondary maintain a minimum clearance of 10 inches from top of insulator to lowest point of PT bracket. For under built, maintain a minimum clearance of 3 feet from middle of crossarm to lowest point of PT bracket.
13. Use insulated butt-splices (SAP 10111371) to connect the secondary PT, black and white wires (120 VAC) inside the ADMO.
14. Per [DC 535](#), Wildlife Protection shall be constructed and installed as applicable for insulators, taps, leads, arresters, cable terminations, and equipment bushings.
15. Construction crew shall coordinate the installation of new and updated RCS with Distribution Automation Engineering in order to perform an end point test (EPT) and commission unit in service.
16. When primary neutral ground exist on the same pole, it shall be a separately installed ground from that of the common equipment ground.
17. The uppermost rod guide shall be located 3 feet MIN to 5 feet MAX below the underside of the switch crossarm. The lowest rod guide shall be located 6'-11" above the upper mounting bolt of the ADMO cabinet. Distribute additional rod guides uniformly at 6 feet maximum and maintain at least 10 inches clearance between the upper edge of each rod guide and the lower edge of the straight coupler.

AP 337	Automated 600 A, 17 kV Omni-Rupter Load-Break Switches	Approved by: <i>ajf</i>
Sheet 6 of 15	What's Changed?	Effective Date: 01-25-2019
DOH		

Scope AP 337.4 Automated 600 A, 17 kV Omni-Rupter Vertical Dual Circuit Switch

Figure AP 337-4: Automated 600 A, 17 kV Omni-Rupter Vertical Dual Circuit Switch

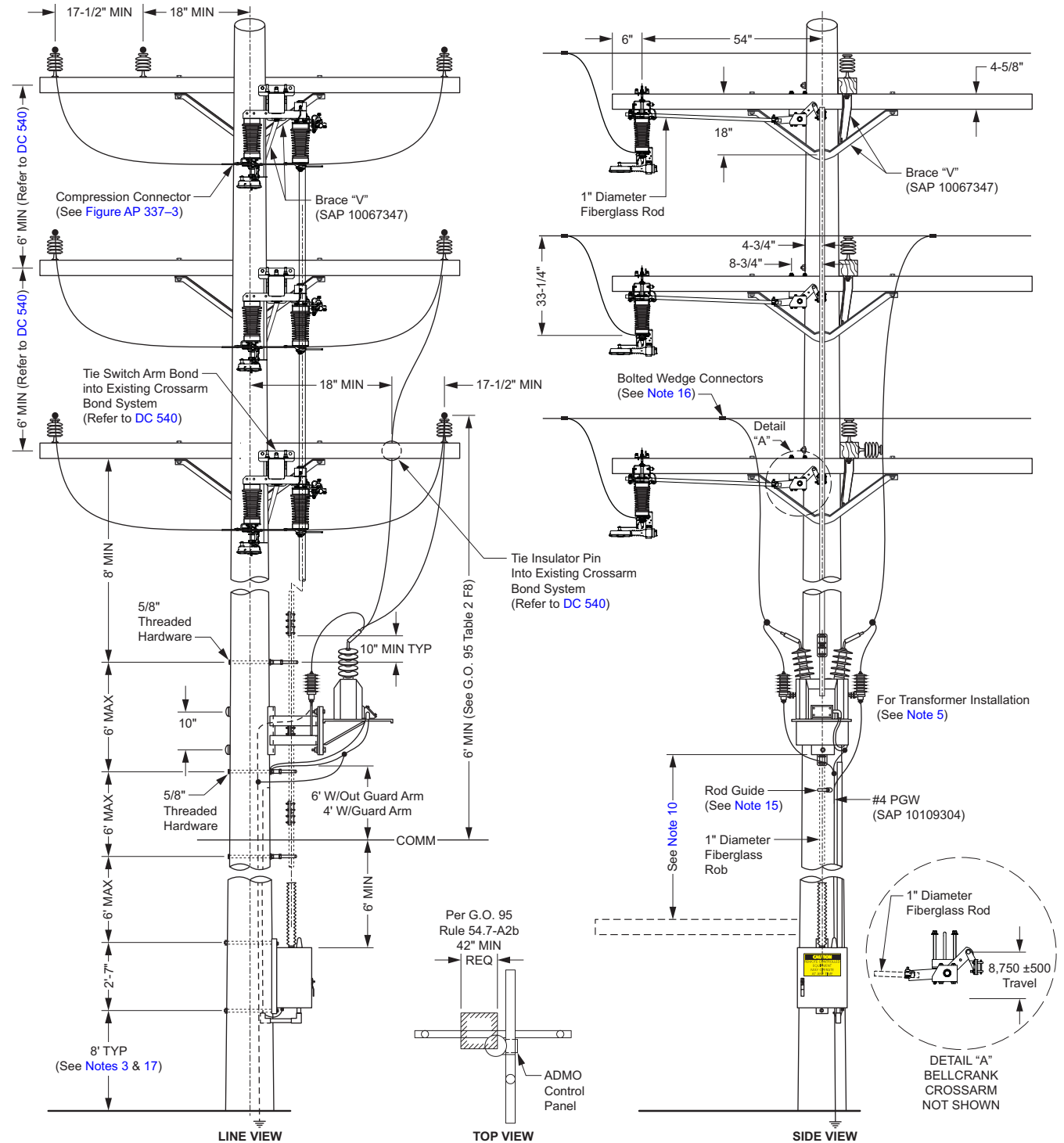

Approved by:

ajf

Automated 600 A, 17 kV Omni-Rupter Load-Break Switches

Effective Date:
01-25-2019

What's Changed? New scope for 600A 17 kV Vertical Dual Circuit switch construction.

AP 337

Sheet 7 of 15

DOH

Note(s):

1. See [PO 120](#) for HIGH VOLTAGE sign installation requirements.
2. See [AP 336](#) for Omni-Rupter switch and operating rod installation details.
3. See [Table AP 337-2](#) for ADMO mounting height criteria.
4. See [AP 360](#) for Cleveland Price Automated Motor Operator (ADMO) and joint pole PVC operating rod cover installation.
5. See [AP 363](#) for dry type potential transformer installation details.
6. Verify switch blades are fully closed and the bell crank over-toggled when installing rod/handle assembly.
7. Verify that the operating rod clamp at the bell crank is connected at the most outward position hole (see Detail A).
8. Verify that the ADMO stroke is set to 9-1/8-inches (Hole 4). Refer to DOM SW-11 Section 4.3 for details on stroke adjustment.
9. Surge arrestors, potential transformers secondary neutral, and the ADMO cabinet shall be connected to a common equipment ground to minimize any potential ground differences between the equipment (see [GR 105](#) and [Scope AP 337.5](#)).
10. For secondary maintain a minimum clearance of 10 inches from top of insulator to lowest point of PT bracket. For under built, maintain a minimum clearance of 3 feet from middle of crossarm to lowest point of PT bracket.
11. Use insulated butt-splices (SAP 10111371) to connect the secondary PT, black and white wires (120 VAC) inside the ADMO.
12. Per [DC 535](#), Wildlife Protection shall be constructed and installed as applicable for insulators, taps, leads, arresters, cable terminations, and equipment bushings.
13. Construction crew shall coordinate the installation of new and updated Remote Control Switch (RCS) with Distribution Automation Engineering in order to perform an end point test (EPT) and commission unit in service.
14. When primary neutral ground exists on the same pole, it shall be a separately installed ground from that of the common equipment ground.
15. The uppermost rod guide shall be located 8 feet MIN below the underside of the switch crossarm. The lowest rod guide shall be located 6'-11" above the upper mounting bolt of the ADMO cabinet. Distribute additional rod guides uniformly at 6 feet maximum and maintain at least 10 inches clearance between the upper edge of each rod guide and the lower edge of the straight coupler.
16. For Bolted Wedge Connector see [CO 420](#). If the cable size exceeds the limits of the Bolted Wedge Connector [CO 300](#) or [CO 305](#) to determine which Hot Line Clamp shall be used.
17. If installing ADMO cabinet over traffic lanes, consult Apparatus Engineering for height requirements.
18. Verify phase of both circuits to ensure suitability of this application. Only identical phase can be joined with this method.

AP 337	Automated 600 A, 17 kV Omni-Rupter Load-Break Switches	Approved by: <i>ajf</i>
Sheet 8 of 15	What's Changed? New notes for new Figure AP 337-4.	Effective Date:
DOH		01-25-2019

Scope AP 337.5 Typical Automation Common Equipment Grounding Connections for 600 A, 17 kV Omni-Rupter Load-Break Switches

Figure AP 337-5: Typical Automation Common Equipment Grounding Connections for 600 A, 17 kV Omni-Rupter Load-Break Switches

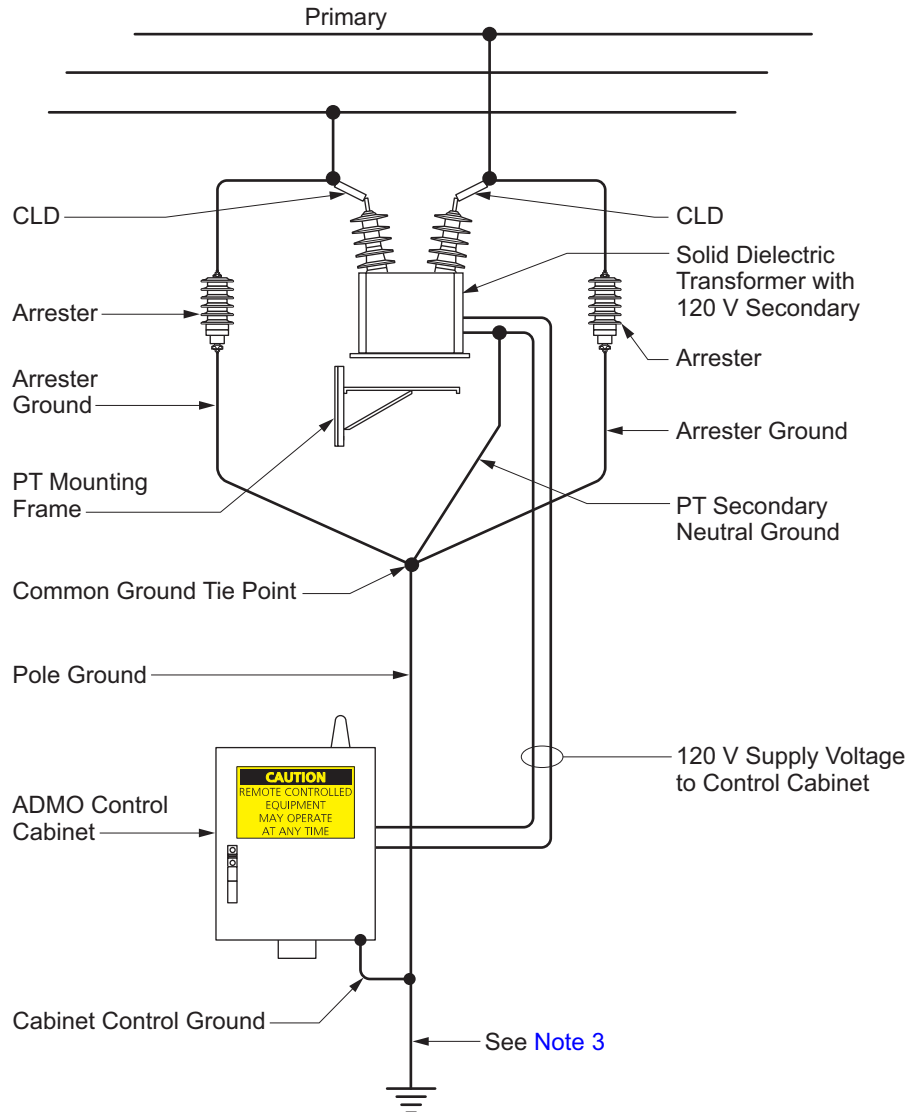

Note(s):

1. The Control PT shall serve no load other than the ADMO control.
2. Surge arresters, potential transformers secondary neutral, and the ADMO cabinet shall be connected to a common equipment ground to minimize any potential ground differences during a surge between the equipment.
3. Preferred method will be to ground with two (2) ground rods per [GR 105](#). If bare copper must be used then it shall be installed in PVC conduit. Maintain proper clearance between the ground and bond or bonded equipment.
4. All Control PT installations shall be protected by surge arresters.
5. When primary neutral ground exists on the same pole, it shall be a separately installed ground from that of the common equipment ground.

Approved by:

ajf

Automated 600 A, 17 kV Omni-Rupter Load-Break Switches

AP 337

Effective Date:
01-25-2019

What's Changed?

Sheet 9 of 15

DOH

Scope AP 337.6 Automated Horizontal-Type Upright Configuration, 600 A, 17 kV, Omni-Rupter Load-Break Switch Dead-Ended on Switch Base

Figure AP 337-6: Automated Horizontal-Type Upright Configuration, 600 A, 17 kV, Omni-Rupter Load-Break Switch Dead-Ended on Switch Base

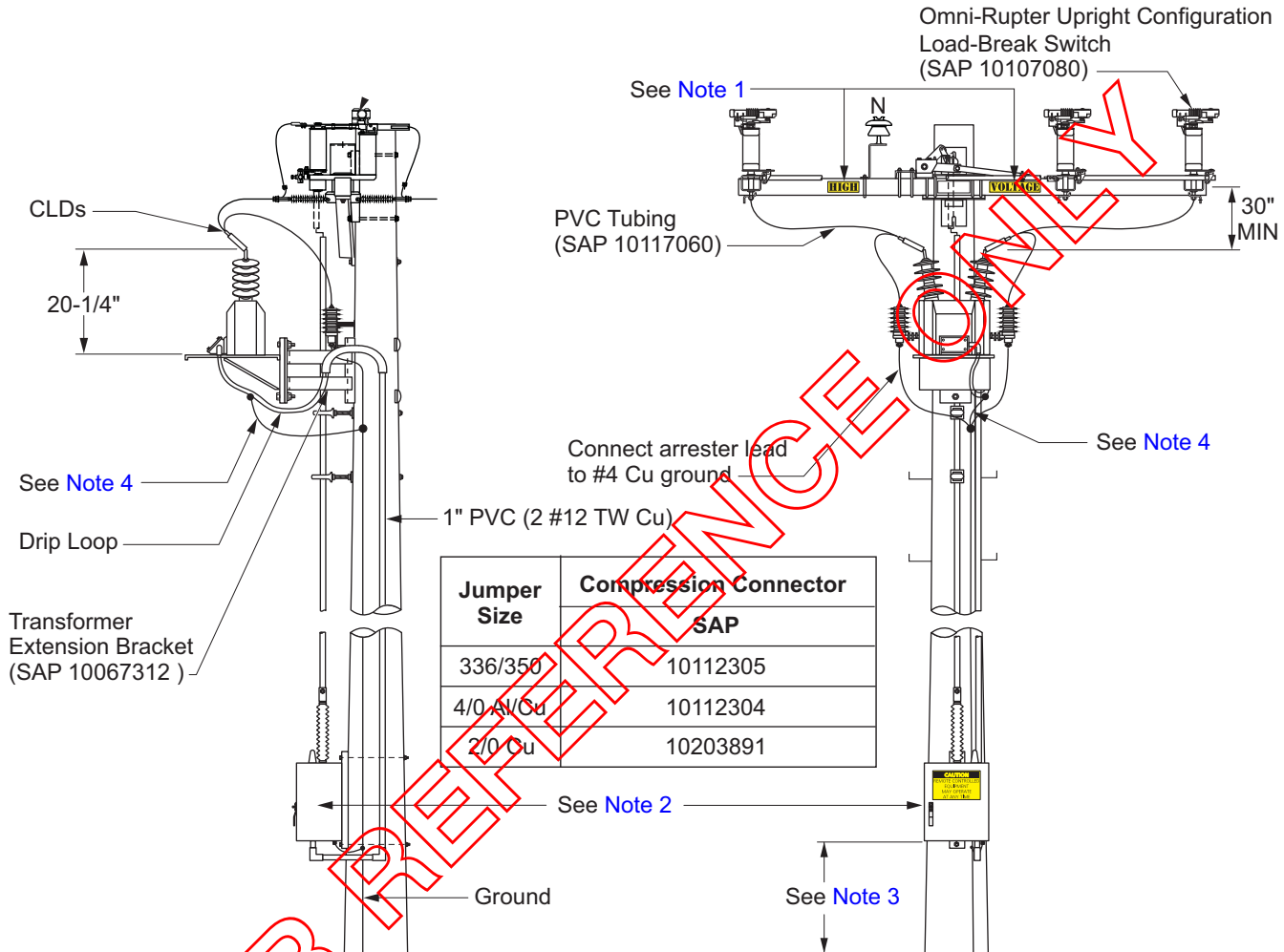

Note(s):

1. See PO 120 for HIGH VOLTAGE sign installation requirements.
2. ADMO SAP 10107141.
3. See Table AP 337-2.
4. Surge arrestors, potential transformers secondary neutral, and the ADMO cabinet shall be connected to a common ground to minimize any potential ground differences between the equipment (see GR 105 and Scope AP 337.5).
5. Use insulated butt-splices (SAP 10111371) to connect the secondary PT, black and white wires (120 VAC) inside the ADMO.
6. Per DC 535, Wildlife Protection shall be constructed and installed as applicable for insulators, taps, leads, arresters, cable terminations, and equipment bushings.

Scope AP 337.7 Automated Horizontal-Type Upright Configuration, 600 A, 17 kV, Omni-Rupter Load-Break Switch Dead-Ended on Switch Base

Figure AP 337-7: Automated Horizontal-Type Upright Configuration, 600 A, 17 kV, Omni-Rupter Load-Break Switch Dead-Ended on Switch Base

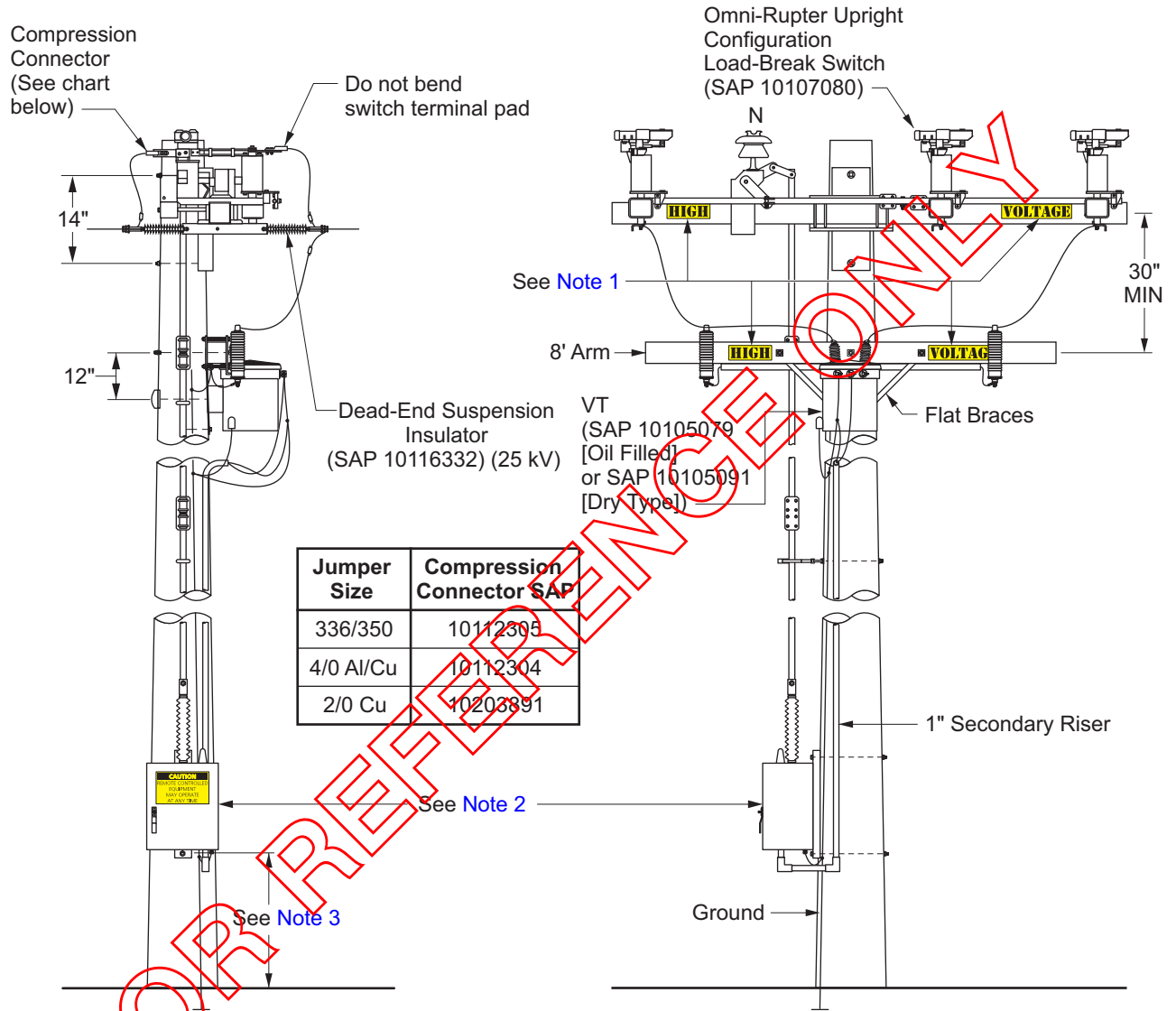

Note(s):

1. See [PC 120](#) for HIGH VOLTAGE sign installation requirements.
2. ADMO (SAP 10107141)
3. See [Table AP 337-2](#).
4. Per [DC 535](#), Wildlife Protection shall be constructed and installed as applicable for insulators, taps, leads, arresters, cable terminations, and equipment bushings.

Approved by:

ajf

Automated 600 A, 17 kV Omni-Rupter Load-Break Switches

AP 337

Effective Date:

01-25-2019

What's Changed?

Sheet 11 of 15

DOH

Scope AP 337.8 Automated Horizontal-Type Upright Configuration, 600 A, 17 kV, Omni-Rupter Switch Below Existing Line Arm, Underbuild

Figure AP 337-8: Automated Horizontal-Type Upright Configuration, 600 A, 17 kV, Omni-Rupter Switch Below Existing Line Arm, Underbuild

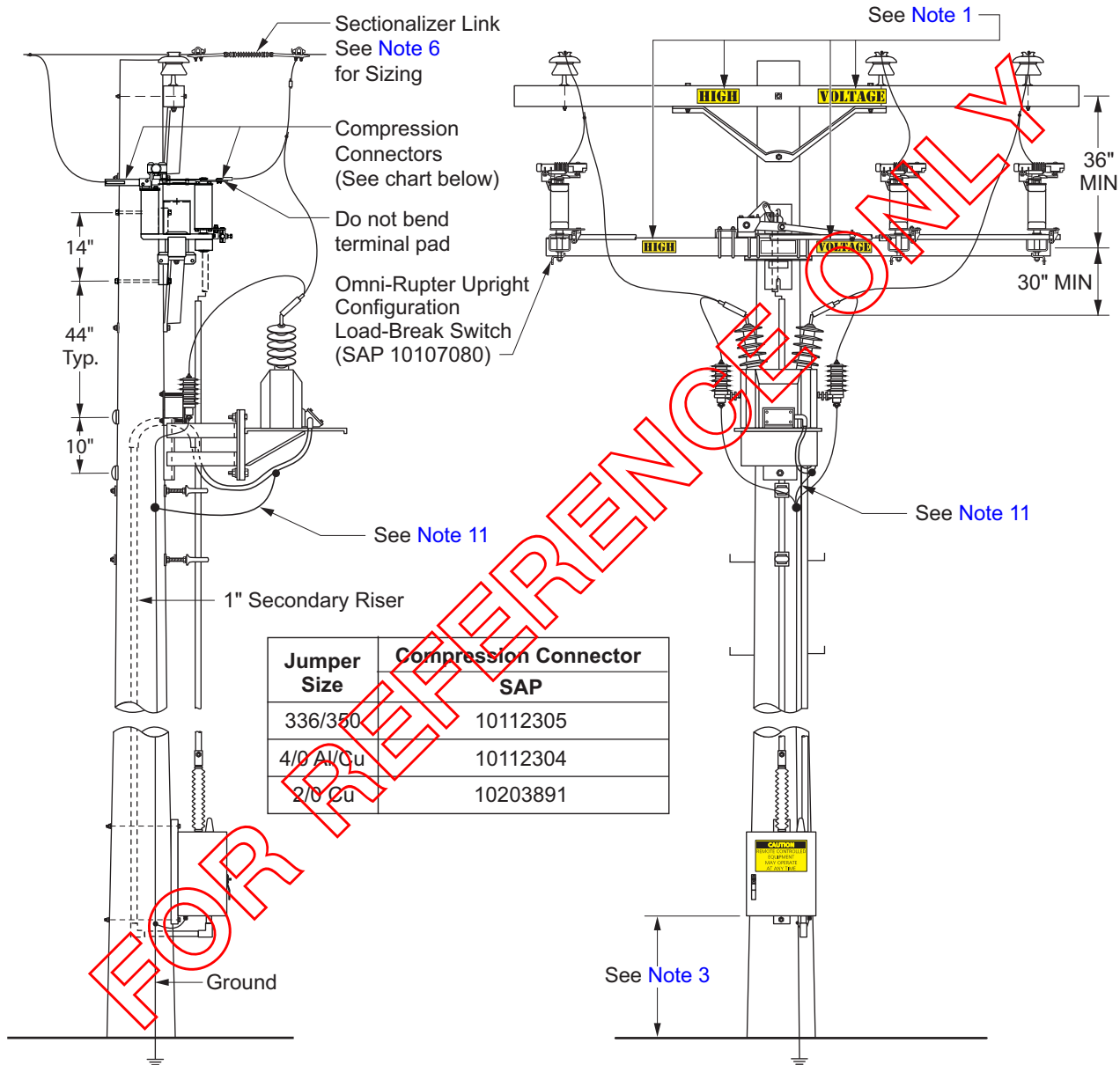

Note(s):

1. See [PO 120](#) for HIGH VOLTAGE sign installation requirements.
2. See [AP 336](#) for Omni-Rupter switch and operating rod installation details.
3. See [Table AP 337-2](#) for ADMO mounting height criteria.
4. See [AP 360](#) for Cleveland Price Automated Motor Operator (ADMO) and joint pole PVC operating rod cover installation.
5. See [AP 363](#) for dry type potential transformer installation details.
6. See [CO 217](#) for Dead Ending and Isolators.
7. Verify switch blades are fully closed and the bell crank over-toggled when installing rod/handle assembly.
8. Do not install 15 kV dead-end suspension insulators; use 25 kV or 33 kV dead-ends.
9. Verify that the switch rocker arm is adjusted to 6 inches (older design) or to its respective hole position (newer design) as shown in [Figure AP 337-1](#).
10. Verify that the ADMO stroke is set to 9-1/8-inches (Hole 2). Refer to DOM SW-11 Section 4.3 for details on stroke adjustment.
11. Surge arrestors, potential transformers secondary neutral, and the ADMO cabinet shall be connected to a common equipment ground to minimize any potential ground differences between the equipment (see [GR 105](#) and [Scope AP 337.6](#)).
12. For secondary maintain a minimum clearance of 10 inches from top of insulator to lowest point of PT bracket. For under built, maintain a minimum clearance of 3 feet from middle of crossarm to lowest point of PT bracket.
13. Use insulated butt-splices (SAP 10111371) to connect the secondary PT, black and white wires (120 VAC) inside the ADMO.
14. Per [DC 535](#), Wildlife Protection shall be constructed and installed as applicable for insulators, taps, leads, arresters, cable terminations, and equipment bushings.
15. Construction crew shall coordinate the installation of new and updated RCS with Distribution Automation Engineering in order to perform an end point test (EPT) and commission unit in service.
16. When primary neutral ground exist on the same pole, it shall be a separately installed ground from that of the common equipment ground.
17. Ensure jumper wire taps will not contact adjacent jumper wire taps. Refer to DOM SW-2 for below line arm construction inspection criteria.

Approved by: 	Automated 600 A, 17 kV Omni-Rupter Load-Break Switches	AP 337
Effective Date: 01-25-2019	What's Changed?	Sheet 13 of 15 DOH

Scope AP 337.9 Automated Horizontal-Type Upright Configuration, 600 A, 17 kV, Omni-Rupter Load-Break Switch Below Existing Line Arm

Figure AP 337-9: Automated Horizontal-Type Upright Configuration, 600 A, 17 kV, Omni-Rupter Load-Break Switch Below Existing Line Arm

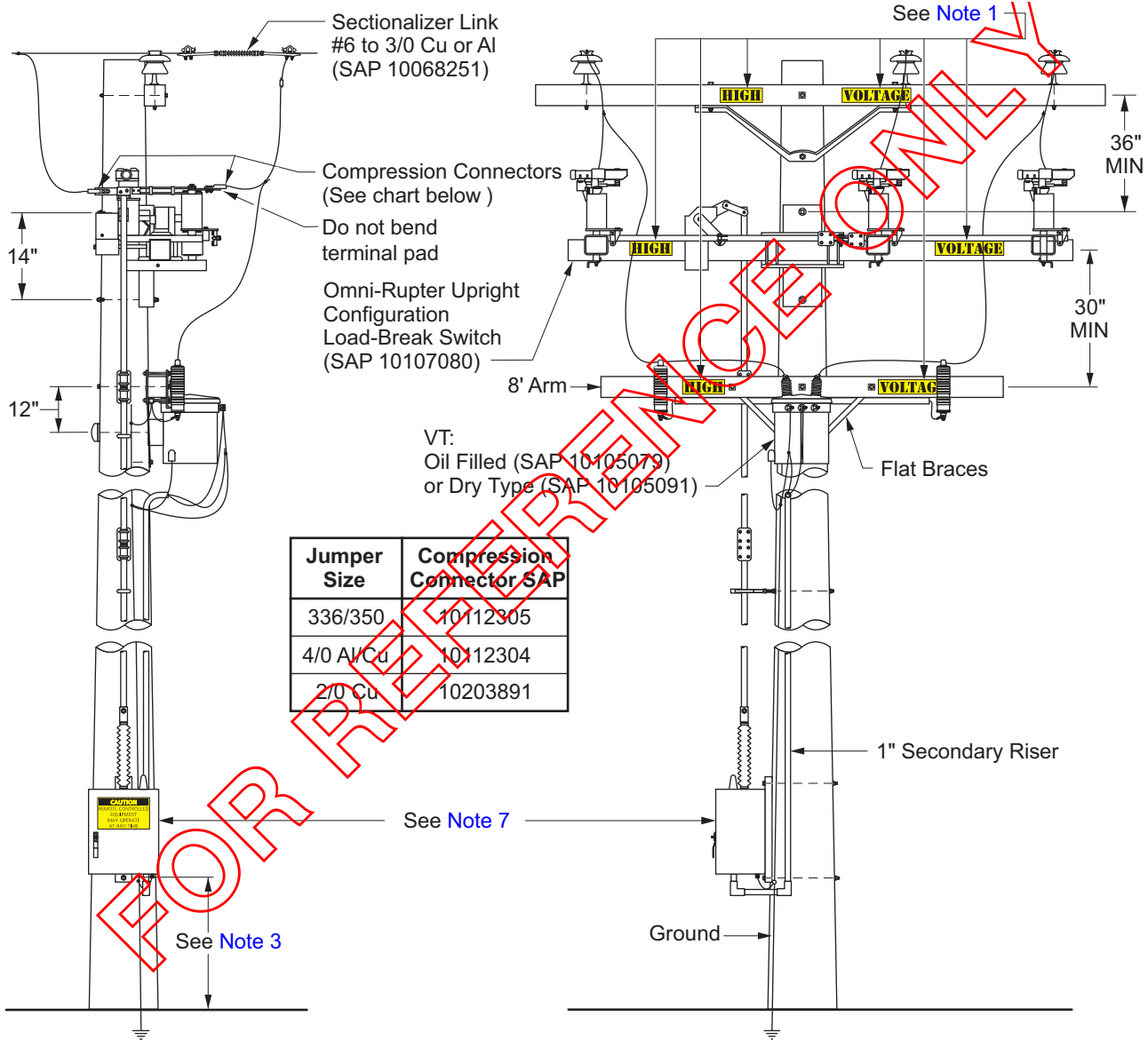

AP 337

Automated 600 A, 17 kV Omni-Rupter Load-Break Switches

Approved by:

a/j

Sheet 14 of 15

What's Changed?

Effective Date:

DOH

01-25-2019

Note(s):

1. See [PO 120](#) for HIGH VOLTAGE sign installation requirements.
2. See [AP 360](#) for Cleaveland/Price® Automated Distribution Motor Operator (ADMO) and joint pole PVC operating rod cover installation.
3. See [Table AP 337-2](#) for ADMO mounting height criteria.
4. See [AP 336](#) for Omni-Rupter switch and operating rod installation details.
5. Switch throw needs to correlate with the Cleaveland/Price® ADMO throw. To accomplish this, the switch rocker arm should be adjusted to 6 inches (see [Figure AP 337-1](#)) and the 9-1/8-inch stroke-hole of the Cleaveland/Price® ADMO should be used (Hole 2).
6. Verify switch blades are fully closed when installing rod assembly.
7. ADMO SAP 10107141.
8. Per [DC 535](#), Wildlife Protection shall be constructed and installed as applicable for insulators, taps, leads, arresters, cable terminations, and equipment bushings.

FOR REFERENCE ONLY

Approved by:	Automated 600 A, 17 kV Omni-Rupter Load-Break Switches	AP 337
Effective Date:		Sheet 15 of 15
01-25-2019		DOH

This page intentionally left blank.

AP 410 Distribution Class Surge Arrester Guide

Scope AP 410.1 Distribution Class Surge Arrester Guide

Figure AP 410-1: Distribution Class Surge Arrester Guide

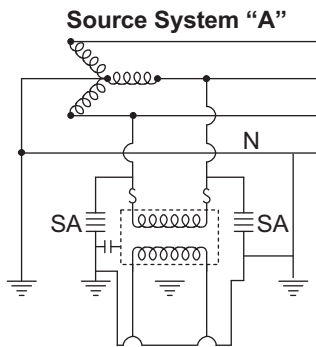

Note: When primary neutral ground exists on transformer pole, it shall be used as the arrester ground.

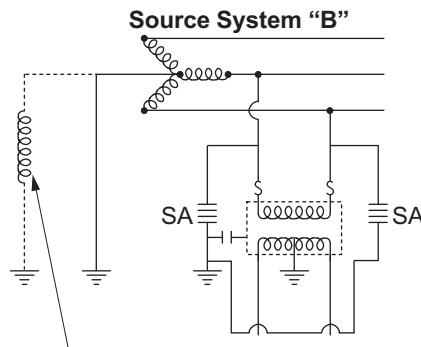

Alternate Source System "C"
(Transformer or Reactor in Series with Ground at Source)

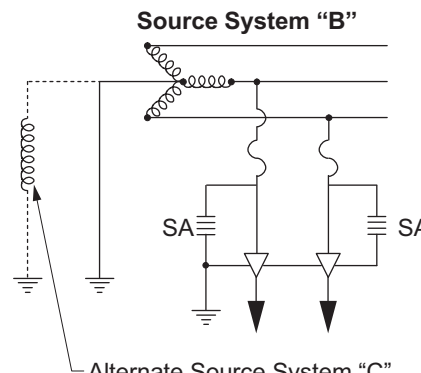
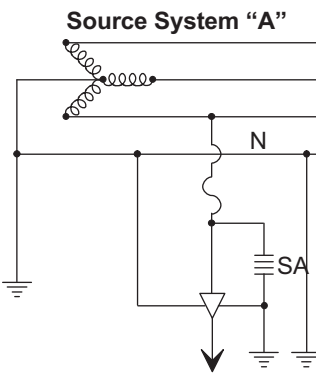
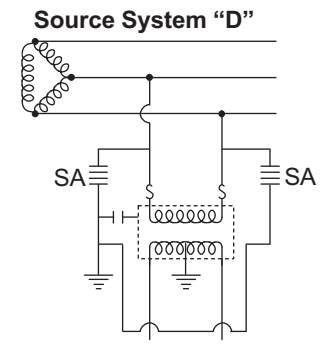

Alternate Source System "C"
(Transformer or Reactor in Series with Ground at Source)

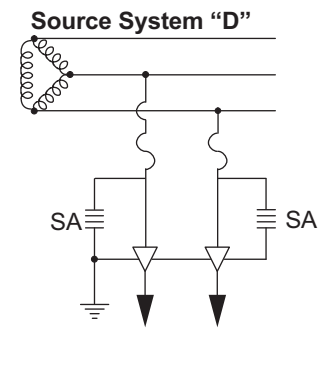

Approved by:

ajf

Distribution Class Surge Arrester Guide

AP 410

Effective Date:
01-25-2019

What's Changed?

Sheet 1 of 3

DOH

Four-Wire Multi-Ground Neutral System (System “A”)

On this type of system only one primary arrester is required on an underground pothead as shown (for 3-phase, one arrester is required per phase). When a single-phase transformer is connected phase-to-phase, two primary arresters are required as shown. The arrester voltage ratings for these applications shall be less than the line-to-line voltage, but greater than the line-to-ground voltage whenever the arresters are installed on a pole where the arrester ground can be connected to the primary neutral. Note that this system may also be grounded at the source by means of a large ground bank or zig-zag ground bank.

Three-Wire Grounded Neutral System (System “B”)

The three-wire grounded neutral system is a wye-connected system with the neutral grounded at the source, either through a reactance as shown or by means of a small ground bank, but with no neutral carried out on the circuit. Such systems require two primary arresters at each single phase transformer or underground pothead (for 3-phase, one arrester is required per phase). The rating of the arresters used with this system should be greater than the line-to-line voltage.

Ungrounded System (System “D”)

An ungrounded system is a delta-connected system which has no connection between neutral and earth. On this type of system the transformers or potheads are connected between phase wires. For effective lightning protection, each single-phase transformer or pothead requires two primary arresters as shown (for 3-phase, one arrester is required per phase) with a voltage rating greater than the line-to-line voltage of the system.

Table AP 410–1: Metal Oxide Type Surge Arresters

Standard Distribution Arresters			
Circuit Voltage (kV)	Nominal Arrester Rating (kV)	MCOV Arrester Rating (kV)	Polymer Housing SAP
2.4 & 4.16/2.4	3	2.6	10109138
4.8	6	5.1	10109139
7.2	9	7.7	10109140
12/6.9 & 12	15	12.7	10109142
16/9.5 & 16 & 24.9/14.4	18	15.3	10109143
33	36	29.0	10109144

Note(s):

1. Metal oxide arresters are supplied with complete NEMA-type crossarm mounting brackets. Discard/salvage the portion of the bracket not required for Edison standard mounting.
2. Use 18 kV rated arresters on the 16/9.5-kV and 16 kV circuits and 15 kV rated arresters on 12/6.9-kV and 12 kV circuits. When arresters are to be mounted on poles where the primary neutral exists, connect arrester grounds to the primary neutral. See example below.
3. Maximum Continuous Operating Voltage (MCOV) applied to a MOV arrester.
4. In animal problem areas (for example, squirrels), use wildlife protector (SAP 10067758).
5. For overhead and underground (riser pole) installations, carry the line and ground connections to the arrester terminals first, and then to the fuseholder, pothead, or other protected equipment (see [AP 434](#)).
6. Keep arrester lead length as short as possible.
7. When arresters are installed back-to-back with a fuseholder or pothead, maximize the distance between the connecting lead and the crossarm to avoid animal contact. Use insulated leads (or covered leads) whenever possible.

Table AP 410–2: Cal-Fire Exempt MOV-Type Surge Arrester for Distribution Applications in Bulletin 322 Areas

Circuit Voltage (kV)	Nominal Arrester Rating (kV)	MCOV Arrester Rating (kV) ^{a/}	Polymer Housing SAP
12/6.9 & 12	15	12.7	10210907

^{a/} MCOV — Maximum Continuous Operating Voltage (Applied to a MOV arrester).

Note(s):

1. This Cal-Fire Exempt Surge Arrester is to be used only if Distribution Apparatus Engineering has first contacted the district manager of Victorville, Barstow, and Yucca.
2. This Cal-Fire Exempt Surge Arrester is installed exactly the same way as standard distribution arresters. All individual surge arrester standards apply to these arresters. Refer to specific construction standards in the DOH and DUG manuals.
3. In animal-problem areas use Wildfire Protector (SAP 10067758).
4. For overhead and underground (riser pole) installations, see [DOH-AP: Apparatus](#), and DUG, Section TP 209.

= PILOT

Figure AP 410–2: Example of Arrester Application on Combination 3-Wire and 4-Wire Distribution Circuit

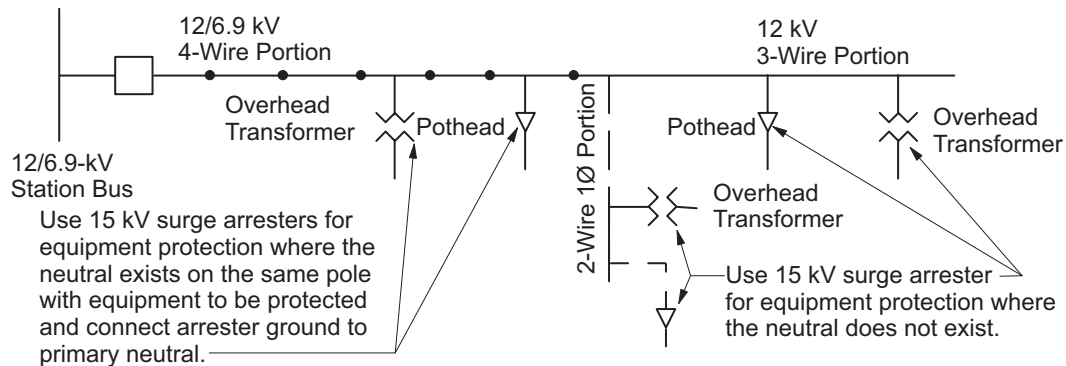

Approved by:

ajf

Distribution Class Surge Arrester Guide

AP 410

Effective Date:
01-25-2019

What's Changed? Table AP 410-2 was added to the standards for the Cal-Fire Exempt Arrester Pilot.

Sheet 3 of 3

DOH

This page intentionally left blank.

AP 505 Three Phase Overhead Electronic Reclosers (FOR REFERENCE ONLY)

Scope AP 505.1 Automatic Circuit Recloser (AR) Installation Details

1.0 General Information

The G&W 27 kV Viper-S AR can be applied on the 4 kV, 12 kV, and 16 kV systems. The G&W 38 kV Viper-S AR can be applied on the 25 kV and 33 kV systems. The G&W Viper-S AR has a continuous current rating of 600 amps and an interrupting rating of 12.5 KA symmetrical. The Viper-S AR utilizes 120 VAC for control power.

2.0 Control Power Transformer (CPT) Fusing

All new AR installations shall be automated with the installation of a NetComm radio. The following fusing practices shall be implemented for the CPT:

2.1 CPT located on the same pole (preferred)

A primary current-limiting device (CLD) and secondary fuse shall be used for protection with the solid dielectric transformers. The secondary fuse is supplied with the CPT.

Current-limiting devices may be installed on existing unfused oil-filled CPT, provided that the associated AR is automated. Modifying existing installations to include fusing is recommended when other work is being performed at the location. The clearance between the bypass switch crossarm and upper buck arm shall be four feet minimum when CLDs are used.

2.2 CPT located on separate pole (alternate)

The Fault Tamer (FT) fuse with 3 amp cartridge shall be applied for protection on 12 kV, 16 kV and 25 kV systems for CPT's rated up to 1 kVA. 33 kV systems will use the 34.5 kV SMU-20 fuse, 3K. For 4 kV CPT fusing, use the 6 amp 8 kV ELF fuse. The secondary leads shall be dead-ended below the AR. The minimum clearance between the bottom of the AR frame and the dead-end connection is ten inches.

Table AP 505-1: Separately Mounted CPT Fuse SAP Numbers

System Voltage	Fuse Type ^{a/}		Fuseholder ^{a/}		Fuse Cartridge
4 kV	8 kV ELF (6 A)	SAP 10108433	15 kV Cutout	SAP 10107450	—
12, 16, 14.4/25 kV	15 kV FT	SAP 10108640	27 kV Cutout	SAP 10107451	(3 A) SAP 10108481
33 kV	34.5 kV SMU-20, 3K	SAP 10108825	34.5 kV SMD-20	SAP 10107516	—

^{a/} See [PR 128](#) Fault Tamer details including an alternate material number for the combined fuse type and fuseholder.

Approved by: <i>ajf</i>	Three Phase Overhead Electronic Reclosers (FOR REFERENCE ONLY)	AP 505
Effective Date: 01-25-2019	What's Changed? Standard made "FOR REFERENCE ONLY".	Sheet 1 of 44
		DOH

3.0 Installation Details

Install wildlife guards (SAP 10067758 or SAP 10067753) on all AR bushings and CPT primary bushings without CLDs. To provide a location for grounding at the disconnect switch terminals; leave six-inches of uncovered conductor on the leads that terminate on the recloser.

Install the wildlife-safe current limiting (CL) fuse cover (SAP 10067793) on CPT's with CLD fusing. Protective ground wire (PGW) (SAP 10109302) may be used for taps for the CPT. Wire covers shall be installed on all bare conductor leads. Use wire cover (SAP 10117061) for #2 AWG bare copper. Use wire cover (SAP 10117062) for 2/0 and 4/0 copper.

The CPT (SAP 10105102) has secondary taps for use on either 12 kV or 16 kV applications. One leg of the secondary shall be grounded. For 12 kV applications, X3 shall be grounded. For 16 kV applications, X2 shall be grounded. DO NOT ground the primary neutral at the recloser installation location.

Surge arresters are required for protection of the AR and CPT. Arresters shall be installed on the line and load sides of the AR (see [Table AP 410-1](#)).

To increase the space for maintenance of the AR, 12-foot crossarms and the use of the outer insulator pin positions are recommended for primary underbuild applications.

Underbuild circuits shall have a minimum four-foot clearance between the conductors and the bottom of the AR frame. Communication conductors shall have a minimum four-foot clearance to the bottom of the AR frame. See [DC 200](#) for clearances between conductors and communication levels.

Hard drawn copper wire is required for AR taps for mechanical strength and to prevent interactions of aluminum with the recloser copper alloy terminals. The AR tap requirements are detailed in [Table AP 505-2](#). The standard AR terminals will accept conductor range between #2-500MCM. For larger wire sizes NEMA style terminals can be attached to the AR terminals, (refer to DOM SW-1 for details on replacement parts).

External Neutral CT taps associated with Sensitive Protection Isolated Neutral 4 kV Systems shall be installed with 2.4 kV insulated cable. Details on ampacity, conduit, and cable sizes for the external CT are included in [Table AP 505-2](#) and [Table AP 505-3](#).

FOR REFERENCE ONLY

AP 505	Three Phase Overhead Electronic Reclosers (FOR REFERENCE ONLY)	Approved by: <i>ajf</i>
Sheet 2 of 44	What's Changed? Standard made "FOR REFERENCE ONLY".	Effective Date: 01-25-2019
DOH		

Table AP 505–2: AR Tap Requirement Chart

Item	Recloser Conductor Requirements	Aluminum Span Conductor			Copper Span Conductor	
		#4 through #2 ACSR	1/0 through 4/0 ACSR	336.4 ACSR	#4 through 2/0 Cu	4/0 Cu
1	Leads between the span conductors and disconnect switches	#2 Cu Hard Drawn SAP 10109330	2/0 Cu Hard Drawn SAP 10109331	4/0 Cu Hard Drawn SAP 10109332	2/0 Cu Hard Drawn SAP 10109331	4/0 Cu Hard Drawn SAP 10109332
2	Leads between the disconnect switches and the AR terminals	2/0 Cu Hard Drawn SAP 10109331	4/0 Cu Hard Drawn SAP 10109332	4/0 Cu Hard Drawn SAP 10109332	4/0 Cu Hard Drawn SAP 10109332	4/0 Cu Hard Drawn SAP 10109332
3	Recommended leads between the Neutral disconnect and the Neutral CT terminals ^{a/} (4 kV isolated neutral only)	2 Runs #6 Insulated Cu Cable SAP 10110173	1 Run 4/0 Insulated Cu Cable SAP 10110187	1 Run 350 kcmil Insulated Cu Cable SAP 10110188	1 Run 4/0 Insulated Cu Cable SAP 10110187	1 Run 350 kcmil Insulated Cu Cable SAP 10110188
4	Maximum Loading (amps) ^{b/ c/}	160-210	280-415	540	195-405	540

- ^{a/} The Recommended CT wiring is based on the largest wire ampacity for the range of the chart. The Neutral conductor capacity is recommended to be 75 percent of the phase conductors, with a minimum capacity of 50 percent. See [Table AP 505–3](#) for alternative conductor options.
- ^{b/} Loading can be limited by the AR ratings, tap sizes, and span wire sizes. The values in the chart assume an AR continuous rating of 630-amperes, the range is based on the available range of the span conductors.
- ^{c/} In some situations the AR minimum trip settings may be required to be higher than the ampacity of the line section to allow for proper coordination.

Table AP 505–3: 2.4 kV Insulated Cable Ampacities and Conduit Recommendations for the AR Neutral CT Conductor

SAP	Size (AWG/kcmil)	Ampacity ^{a/}	MIN Conduit for 1 Run ^{b/}	MIN Conduit for 2 Runs ^{b/}	MIN Conduit for 3 Runs ^{b/}
10110173	#6	75	1-inch	2-inch	2-inch
10110174	#4	97	1-inch	2-inch	2-inch
10110175	#2	130	1.5-inch	2-inch	2.5-inch
10110187	4/0	280	1.5-inch	3-inch	3-inch
10110188	350	385	2-inch	4-inch	4-inch
10110189	500	475	2-inch	4-inch	4-inch

- ^{a/} The ampacity can be doubled or tripled with installation of multiple conductor runs.
- ^{b/} Two-hole stackable lugs may be installed for up to four runs of cable for the CT and disconnect switches. It is best practice to limit the parallel runs to two cables to avoid stacking connectors on both sides of the terminal pads.

4.0 Automatic Recloser prior to Commissioning after Construction

After the installation of the recloser, the equipment needs to be commissioned by Distribution Apparatus Test. The construction crew shall configure the equipment for Distribution Apparatus Test as follows:

- Line and Load disconnects connected to both the source and the recloser.
- Line and Load disconnects in the OPEN position.
- AR breaker in the OPEN position.
- By-pass switch in CLOSED position, unless otherwise indicated on the Work Order.
- PT tapped to the primary circuit (see [Figure AP 505-1](#) for secondary connection details):
 - If the circuit is energized, check for 120 V at the controller and connect the controller battery.
 - If the circuit is not energized, controller battery shall not be connected.
- Release to substation jurisdiction that recloser has been installed and is NOT READY FOR SERVICE, Follow the procedure stated in System Operating Bulletin #25.

Figure AP 505-1: 120 V Control Power Connections in the SEL 351R-2

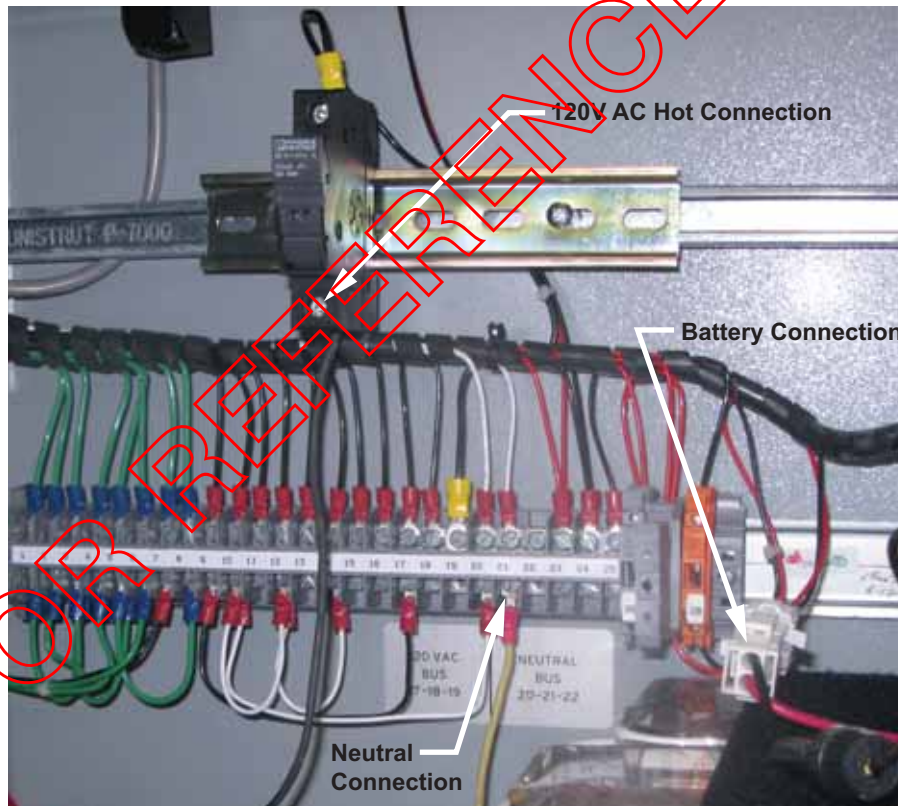

5.0 Controller Mounting Height Requirements

For operations and maintenance access to the recloser controller the preferred mounting height is five feet, only when the mounting height conditions are satisfied. When the site conditions do not allow for the preferred mounting range the controller shall be mounted at eight feet or higher. See [Table AP 505-4](#) for recloser controller mounting height requirements.

Table AP 505-4: Recloser Controller Mounting Height Requirements

Preferred	5' above ground (Lower conditions shall be met, as shown below)
Higher than 8 feet	<p>At a specified height, as determined by the planner, after contacting the responsible Apparatus Foreman due to the following conditions:</p> <ul style="list-style-type: none"> • Ability to work over fence with bucket truck • Bus Stop • Communications obstacles • Fences and walls • Parking area • Slopes • Traffic — vehicle and pedestrian • Trees and shrubs <p>Examples:</p> <ul style="list-style-type: none"> • 6' below communication cable (usually 12'–15' above ground) • 4' below communication cable with no junction box (usually 14'–17' above ground) • 13'-6" above ground level to clear truck traffic <p>Note: Contact the responsible Apparatus Foreman if the control is planned to be mounted above 8'.</p>
Lower (4–8 feet)	<p>All the following conditions shall be met (Usually in Rural Areas):</p> <ul style="list-style-type: none"> • Away from obstacles - fences and walls • Away from parking area • Away from traffic signals • Away from traffic - vehicle and pedestrian <p>Or in SCE Substation and locked fence areas</p>

FOR REFERENCE ONLY

Approved by: 	Three Phase Overhead Electronic Reclosers (FOR REFERENCE ONLY)	AP 505
Effective Date: 01-25-2019	What's Changed? Standard made "FOR REFERENCE ONLY".	Sheet 5 of 44
		DOH

Scope AP 505.2 G&W Viper-S AR for 4 kV Installations

Figure AP 505-2: Typical G&W Viper-S Electronic ARs for 4 kV with the CPT Located on the Same Pole

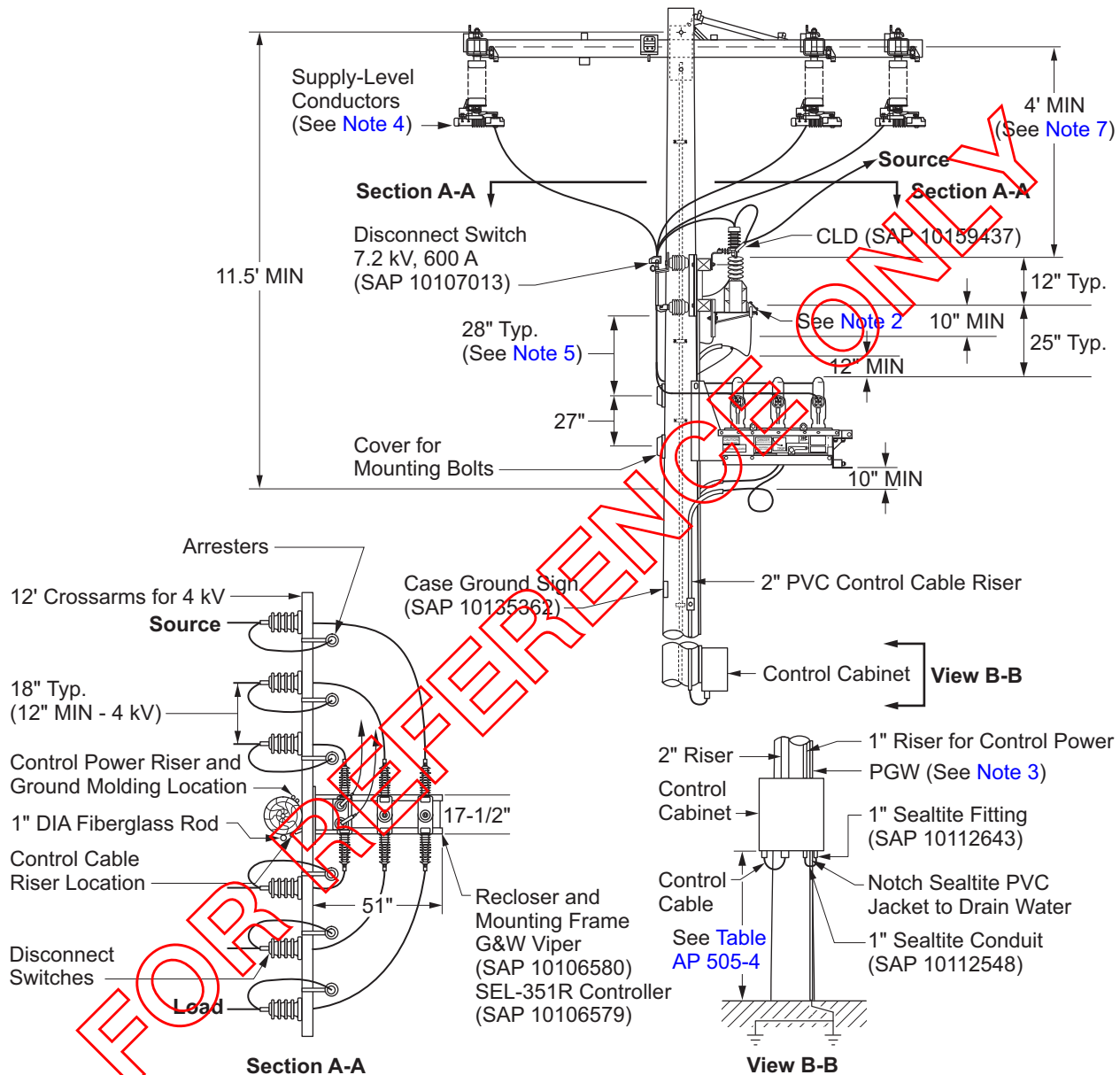

Note(s):

1. The CPT shall serve no load other than the AR and AR controls.
2. Control Power Transformer (CPT) Material Number — 2400 V/120 V CPT (SAP 10177910); 4160 V/120 V CPT (SAP 10177919); 4800 V/120 V (SAP 10177922). Mount the CPT Bracket (SAP 10104923) using the lower cross-arm through-bolt. Install covers on the bolt heads. Do not ground CPT mounting bracket.

AP 505

Sheet 6 of 44

DOH

Three Phase Overhead Electronic Reclosers (FOR REFERENCE ONLY)

What's Changed? Standard made "FOR REFERENCE ONLY".

Approved by:

ajf

Effective Date:

01-25-2019

3. See [Scope AP 505.7](#) for AR, control, and CPT grounding. See [Scope AP 505.8](#) for AR, control, and CPT grounding when the CPT is mounted on an adjacent pole (alternate method). See [GR 105](#) for ground conductor and connection requirements.
4. See [AP 336](#) for installation requirements for Omni-Rupter bypass switch, the supply conductors shall be dead-ended to the switch crossarm.
5. Maintain 12-inch minimum separation between high voltage bushings, and the transformer tank, and all secondary leads.
6. See [AP 410](#) and [GR 107](#) for surge arrester installation requirements.
7. Maintain 18-inch minimum (radial) separation between CPT or arrester leads/bushings and the switch blades.
8. To provide a location for grounding at the disconnect switch terminals; leave 6-inches of uncovered conductor on the leads that terminate on the recloser.
9. Per [DC 535](#), Wildlife Protection shall be constructed and installed as applicable for insulators, taps, leads, arresters, cable terminations, and equipment bushings.

FOR REFERENCE ONLY

Approved by: 	Three Phase Overhead Electronic Reclosers (FOR REFERENCE ONLY)	AP 505
Effective Date: 01-25-2019	What's Changed? Standard made "FOR REFERENCE ONLY".	Sheet 7 of 44 <div style="font-size: 24pt; font-weight: bold; margin-top: 5px;">DOH</div>

Figure AP 505-3: Typical G&W Viper-S Electronic ARs for 4 kV with the CPT Located on the Same Pole (Alternate Method Using Hughes Adapter)



AP 505

Three Phase Overhead Electronic Reclosers (FOR REFERENCE ONLY)

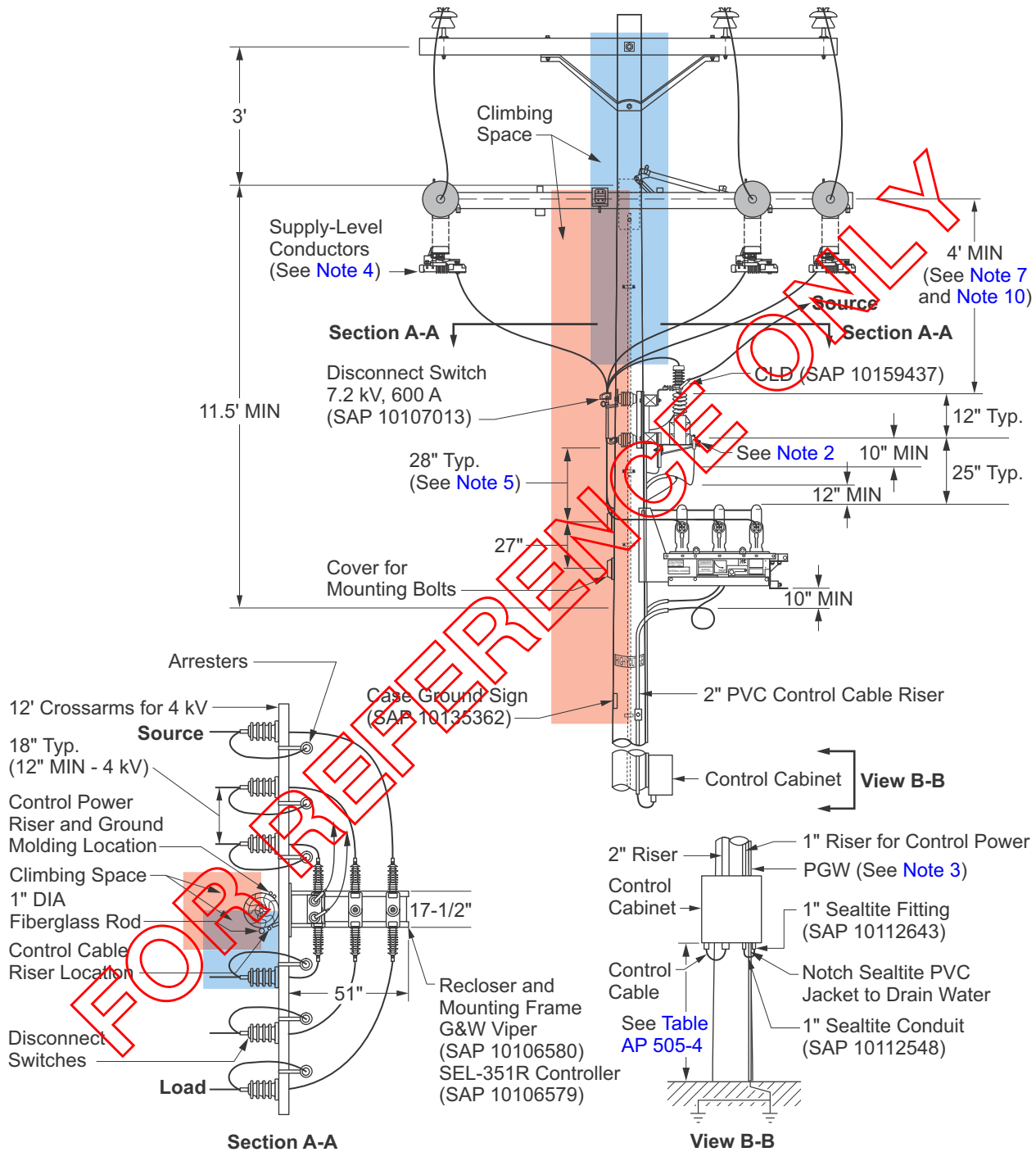
Approved by:

a/j

Sheet 8 of 44

What's Changed? Standard made "FOR REFERENCE ONLY".

Effective Date:

DOH

01-25-2019

Note(s):

1. The CPT shall serve no load other than the AR and AR controls.
2. Control Power Transformer (CPT) Material Number — 2400 V/120 V CPT (SAP 10177910); 4160 V/120 V CPT (SAP 10177919); 4800 V/120 V (SAP 10177922). Mount the CPT Bracket (SAP 10104923) using the lower cross-arm through-bolt. Install covers on the bolt heads. Do not ground CPT mounting bracket.
3. See [Scope AP 505.7](#) for AR, control, and CPT grounding. See [Scope AP 505.8](#) for AR, control, and CPT grounding when the CPT is mounted on an adjacent pole (alternate method). See [GR 105](#) for ground conductor and connection requirements.
4. See [AP 336](#) for installation requirements for Omni-Rupter bypass switch.
5. Maintain 12-inch minimum separation between high voltage bushings, and the transformer tank, and all secondary leads.
6. See [AP 410](#) and [GR 107](#) for surge arrester installation requirements.
7. Maintain 18-inch minimum (radial) separation between CPT or arrester leads/bushings and the switch blades.
8. To provide a location for grounding at the disconnect switch terminals; leave 6-inches of ~~uncovered~~ conductor on the leads that terminate on the recloser.
9. Per [DC 535](#), Wildlife Protection shall be constructed and installed as applicable for insulators, taps, leads, arresters, cable terminations, and equipment bushings.
10. Taps from the Hughes adapters to disconnect switches shall be formed so as not to obstruct the required climbing space. When possible, the inside (closest to the pole) and middle disconnects should be tapped to the Omni-Rupter phases furthest from the climbing space.
11. Climbing Space required — 30" × 30".

FOR REFERENCE ONLY

Approved by: 	Three Phase Overhead Electronic Reclosers (FOR REFERENCE ONLY)	AP 505
Effective Date: 01-25-2019	What's Changed? Standard made "FOR REFERENCE ONLY".	Sheet 9 of 44 <div style="font-size: 24px; font-weight: bold; margin-top: 5px;">DOH</div>

Figure AP 505-4: G&W Viper-S 27 kV Electronic AR



Note(s):

1. Approximate weight of Automatic Recloser is 500 lb.

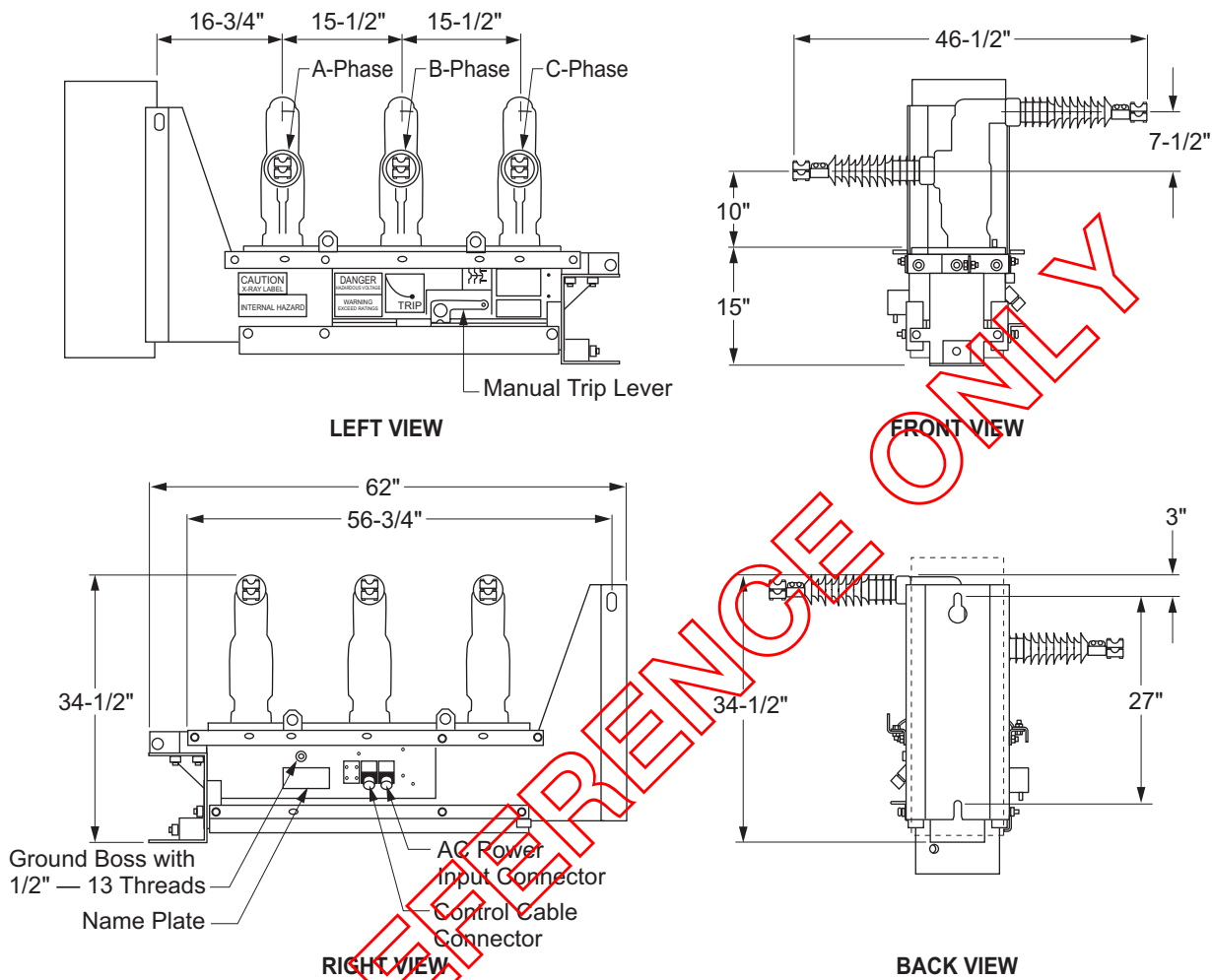
Figure AP 505-5: 4 kV CPT Mounting Bracket Details

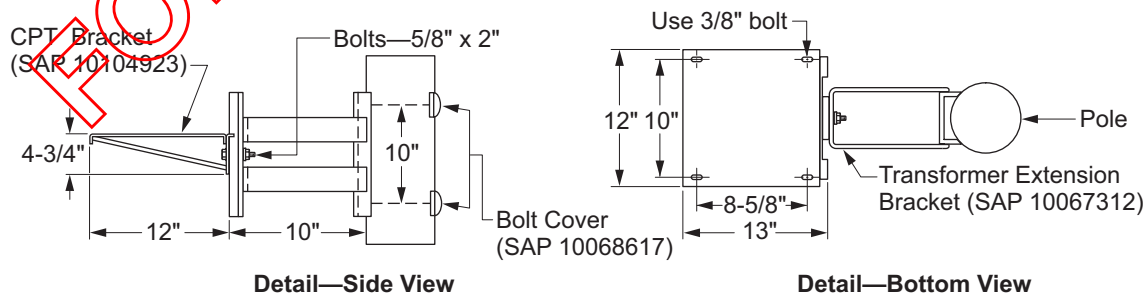

AP 505

Three Phase Overhead Electronic Reclosers (FOR REFERENCE ONLY)

Approved by:

a/j

Sheet 10 of 44

What's Changed? Standard made "FOR REFERENCE ONLY".

Effective Date:

DOH

01-25-2019

Scope AP 505.3 G&W Viper-S AR for 4 kV Installations with Neutral Sensing CT

Figure AP 505-6: Typical G&W Viper-S Electronic ARs for 4 kV with Neutral Sensing CT

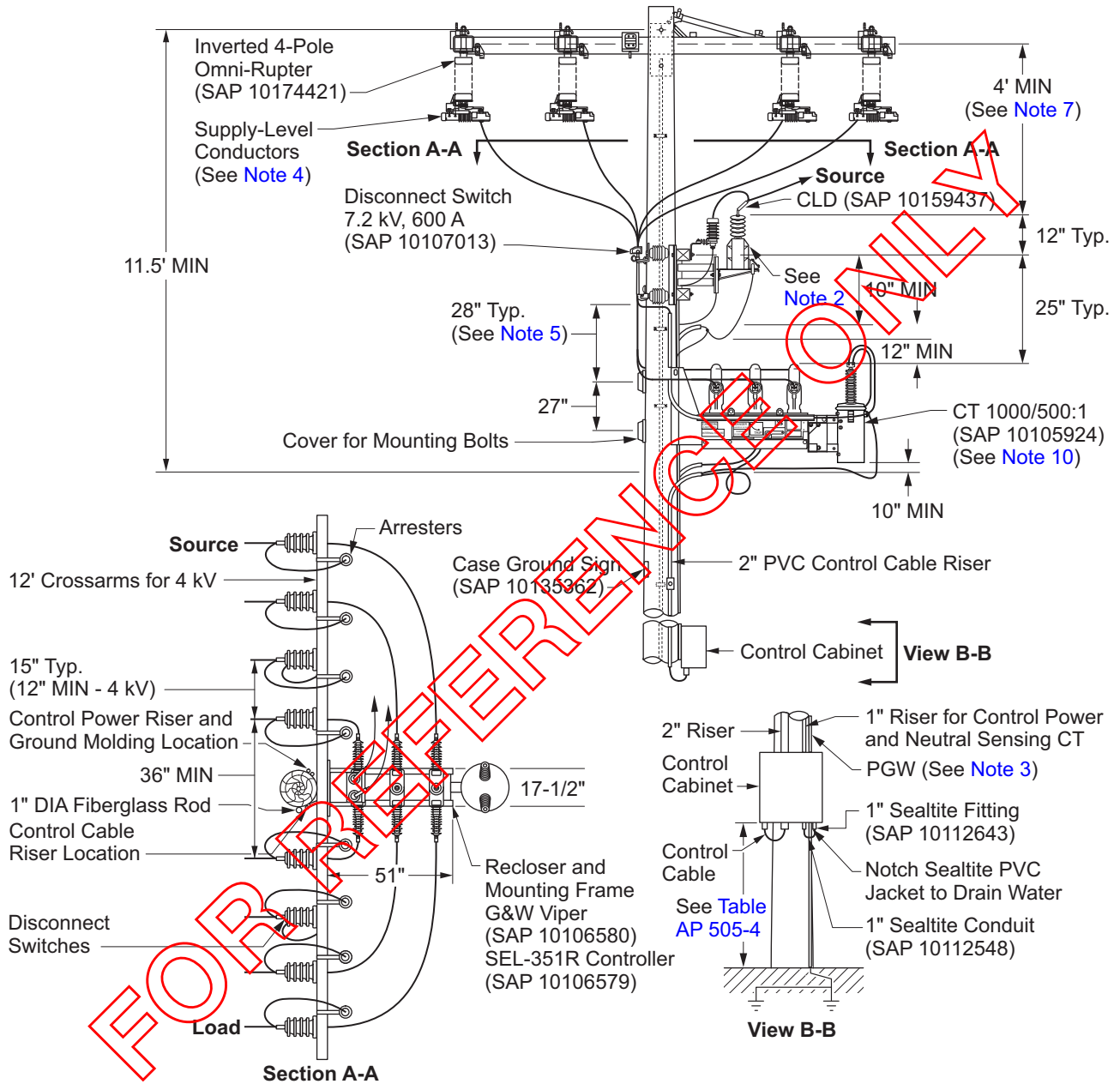

Note(s):

1. The CPT shall serve no load other than the AR and AR controls.
2. Control Power Transformer (CPT) Material Number-2400 V/120 V CPT (SAP 10177910); 4160 V/120 V CPT (SAP 10177919); 4800 V/120 V (SAP 10177922). Mount the CPT Bracket (SAP 10104923) using the lower cross-arm through-bolt. Install covers on the bolt heads. Do not ground CPT mounting bracket.

Approved by: <i>ajf</i>	Three Phase Overhead Electronic Reclosers (FOR REFERENCE ONLY)	AP 505
Effective Date: 01-25-2019	What's Changed? Standard made "FOR REFERENCE ONLY".	Sheet 11 of 44 DOH

3. See [Scope AP 505.7](#) for AR, control, and CPT grounding. See [Scope AP 505.8](#) for AR, control, and CPT grounding when the CPT is mounted on an adjacent pole (alternate method). See [GR 105](#) for ground conductor and connection requirements. The external CT secondary shall be grounded.
4. See [AP 336](#) for installation requirements for Omni-Rupter bypass switch, the supply conductors shall be dead-ended to the switch crossarm.
5. Maintain 12-inch minimum separation between high voltage bushings, the transformer tank, and all secondary leads.
6. See [AP 410](#) and [GR 107](#) for surge arrester installation requirements.
7. Maintain 18-inch minimum (radial) separation between CPT or arrester leads/bushings and the switch blades.
8. To provide a location for grounding at the disconnect switch terminals; leave six-inches of uncovered conductor on the leads that terminate on the recloser.
9. Per [DC 535](#), Wildlife Protection shall be constructed and installed as applicable for insulators, taps, leads, arresters, cable terminations, and equipment bushings.
10. CT primary leads shall be 2.4 kV insulated cable installed in conduit per requirements established in [Scope AP 505.1, Section 3.0](#). The CT is provided with a secondary cable (30-ft. 3C-#16 AWG) with water tight connector that terminates to the CT. The CT secondary cable is installed in the control power riser. CT secondary leads shall be terminated to a shorting test switch in the AR control enclosure.

FOR REFERENCE ONLY

AP 505	Three Phase Overhead Electronic Reclosers (FOR REFERENCE ONLY)	Approved by: <i>ajf</i>
Sheet 12 of 44	What's Changed? Standard made "FOR REFERENCE ONLY".	Effective Date: 01-25-2019
DOH		

Figure AP 505-7: Typical G&W Viper-S Electronic ARs for 4 kV with Neutral Sensing CT (Alternate Method Using Hughes Adapter)

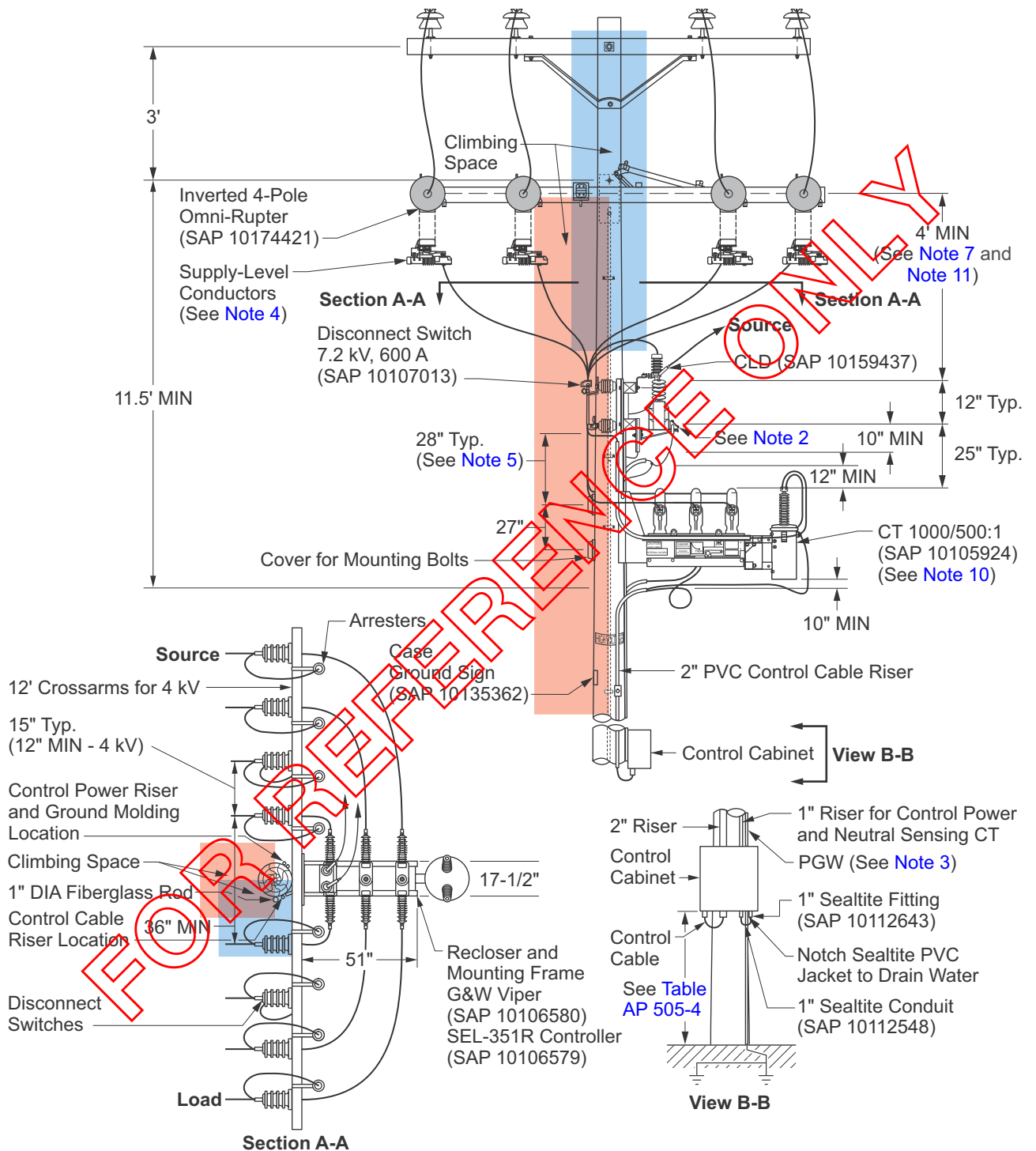

Approved by:

ajf

Three Phase Overhead Electronic Reclosers (FOR REFERENCE ONLY)

AP 505

Effective Date:
01-25-2019

What's Changed? Standard made "FOR REFERENCE ONLY".

Sheet 13 of 44

DOH

Note(s):

1. The CPT shall serve no load other than the AR and AR controls.
2. Control Power Transformer (CPT) Material Number-2400 V/120 V CPT (SAP 10177910); 4160 V/120 V CPT (SAP 10177919); 4800 V/120 V (SAP 10177922). Mount the CPT Bracket (SAP 10104923) using the lower cross-arm through-bolt. Install covers on the bolt heads. Do not ground CPT mounting bracket.
3. See [Scope AP 505.7](#) for AR, control, and CPT grounding. See [Scope AP 505.8](#) for AR, control, and CPT grounding when the CPT is mounted on an adjacent pole (alternate method). See [GR 105](#) for ground conductor and connection requirements. The external CT secondary shall be grounded.
4. See [AP 336](#) for installation requirements for Omni-Rupter bypass switch.
5. Maintain 12-inch minimum separation between high voltage bushings, the transformer tank, and all secondary leads.
6. See [AP 410](#) and [GR 107](#) for surge arrester installation requirements.
7. Maintain 18-inch minimum (radial) separation between CPT or arrester leads/bushings and the switch blades.
8. To provide a location for grounding at the disconnect switch terminals; leave six-inches of uncovered conductor on the leads that terminate on the recloser.
9. Per [DC 535](#), Wildlife Protection shall be constructed and installed as applicable for insulators, taps, leads, arresters, cable terminations, and equipment bushings.
10. CT primary leads shall be 2.4 kV insulated cable installed in conduit per requirements established in [Scope AP 505.1, Section 3.0](#). The CT is provided with a secondary cable (30-ft. 3C-#16 AWC) with water tight connector that terminates to the CT. The CT secondary cable is installed in the control power riser. CT secondary leads shall be terminated to a shorting test switch in the AR control enclosure.
11. Taps from the Hughes adapters to disconnect switches shall be formed so as not to obstruct the required climbing space. When possible, the inside (closest to the pole) and middle disconnects should be tapped to the Omni-Rupter phases furthest from the climbing space.
12. Climbing Space required - 30" x 30".

FOR REFERENCE ONLY

AP 505	Three Phase Overhead Electronic Reclosers (FOR REFERENCE ONLY)	Approved by: <i>ajf</i>
Sheet 14 of 44	What's Changed? Standard made "FOR REFERENCE ONLY".	Effective Date: 01-25-2019
DOH		

Figure AP 505-8: CT Equipment Dimensions

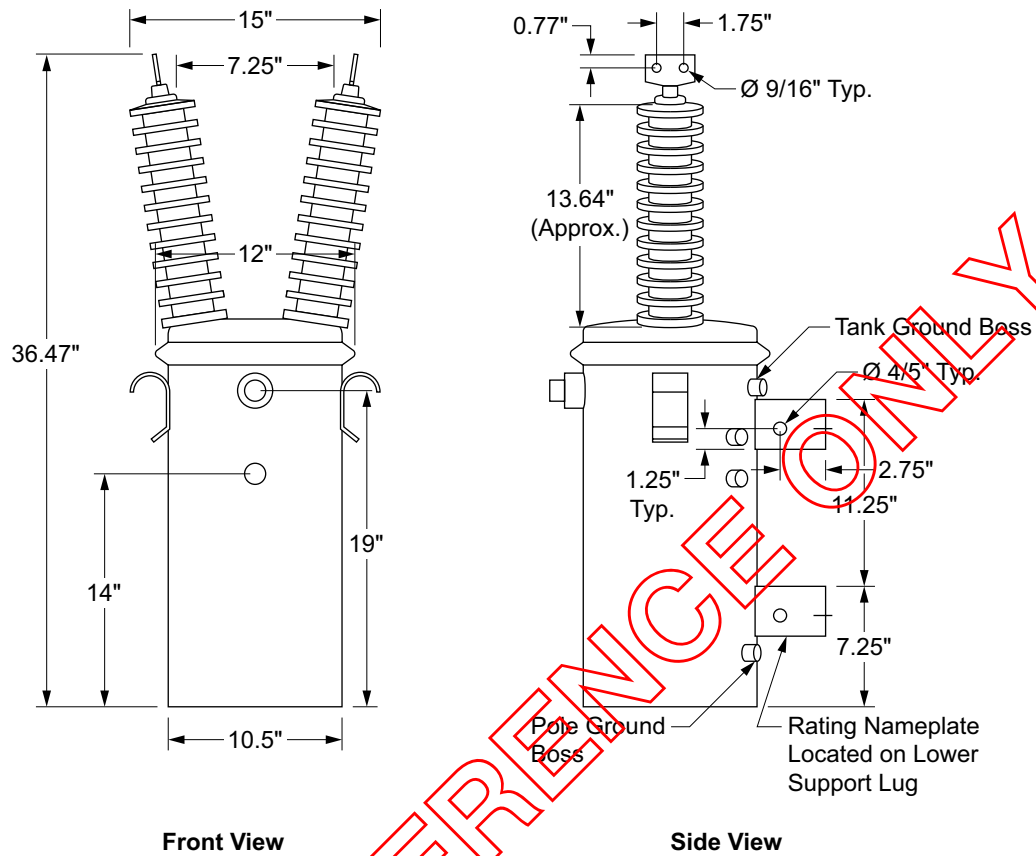

Note(s):

1. Approximate weight of CT is 125 lb.

FOR REFERENCE ONLY

Approved by: 	Three Phase Overhead Electronic Reclosers (FOR REFERENCE ONLY)	AP 505
Effective Date: 01-25-2019	What's Changed? Standard made "FOR REFERENCE ONLY".	Sheet 15 of 44 DOH

Figure AP 505-9: CT Secondary Connection Details



FOR REFERENCE ONLY

Figure AP 505-10: G&W Viper-S 27 kV Electronic AR

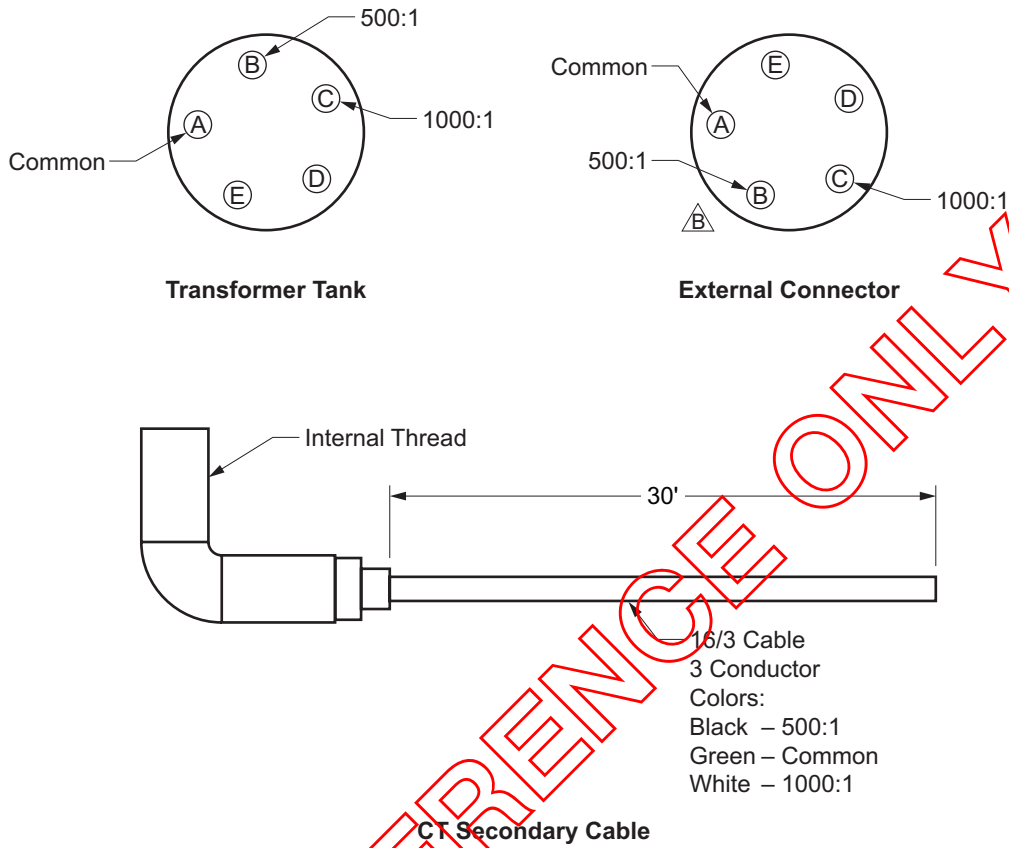
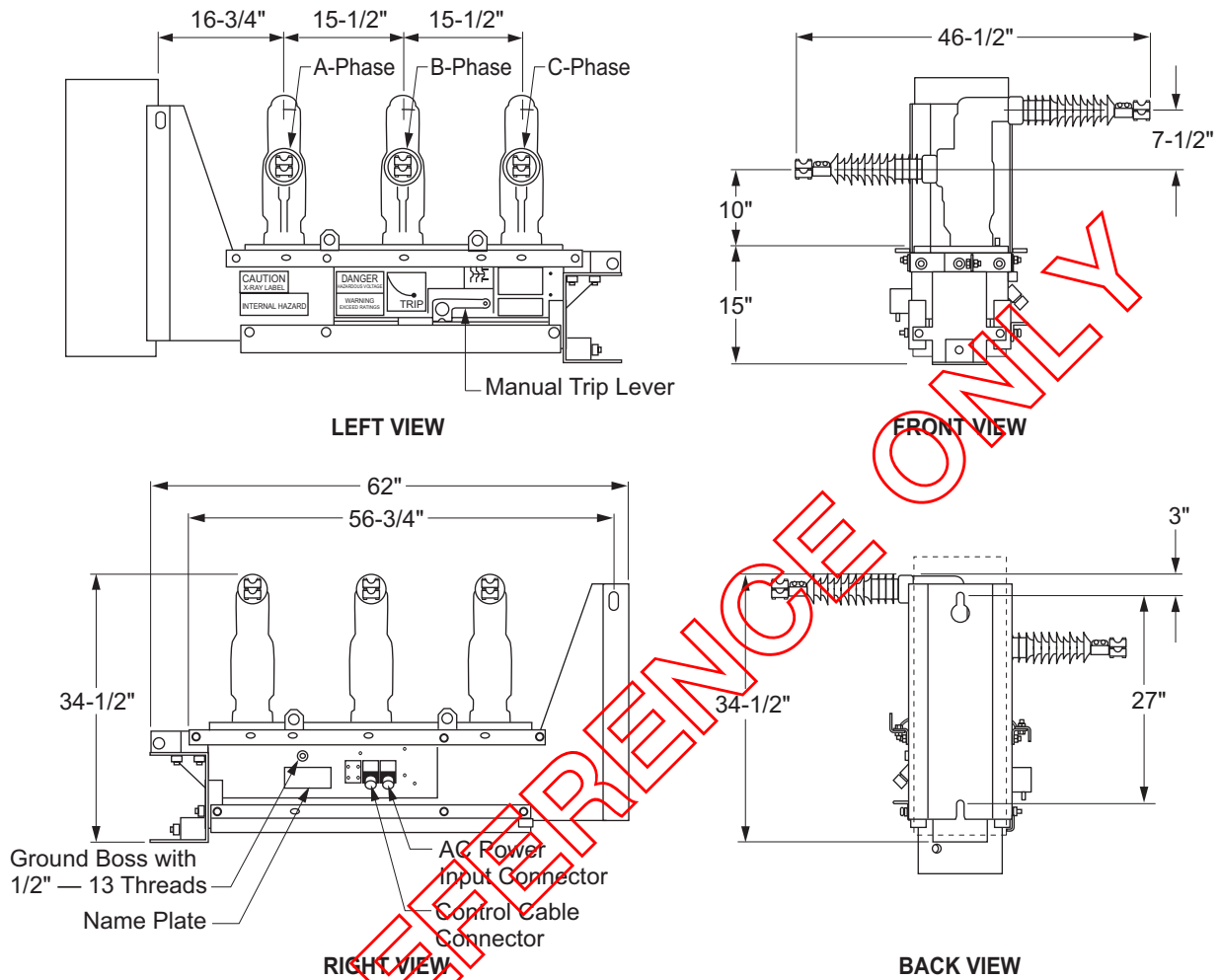

Note(s):

1. Approximate weight of Automatic Recloser is 500 lb.

Figure AP 505-11: 4 kV CPT Mounting Bracket Details

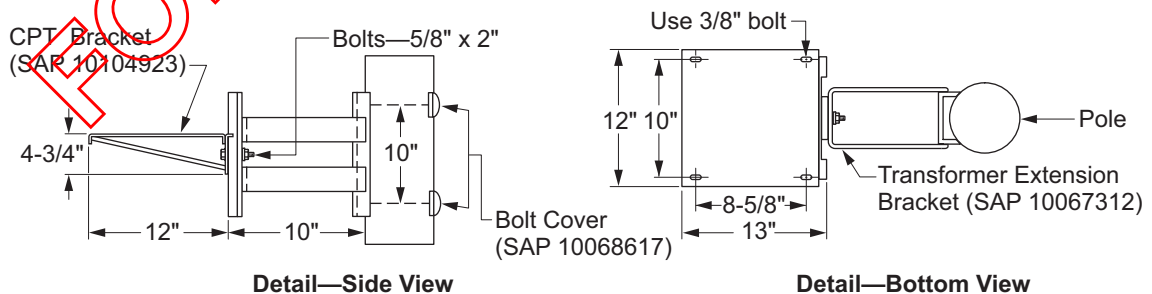

Approved by:

ajf

Three Phase Overhead Electronic Reclosers (FOR REFERENCE ONLY)

AP 505

Effective Date:
01-25-2019

What's Changed? Standard made "FOR REFERENCE ONLY".

Sheet 17 of 44

DOH

Scope AP 505.4 G&W Viper-S AR for 12/16 kV Installations

Figure AP 505-12: Typical G&W Viper-S Electronic ARs for 12/16 kV with the CPT Located on the Same Pole

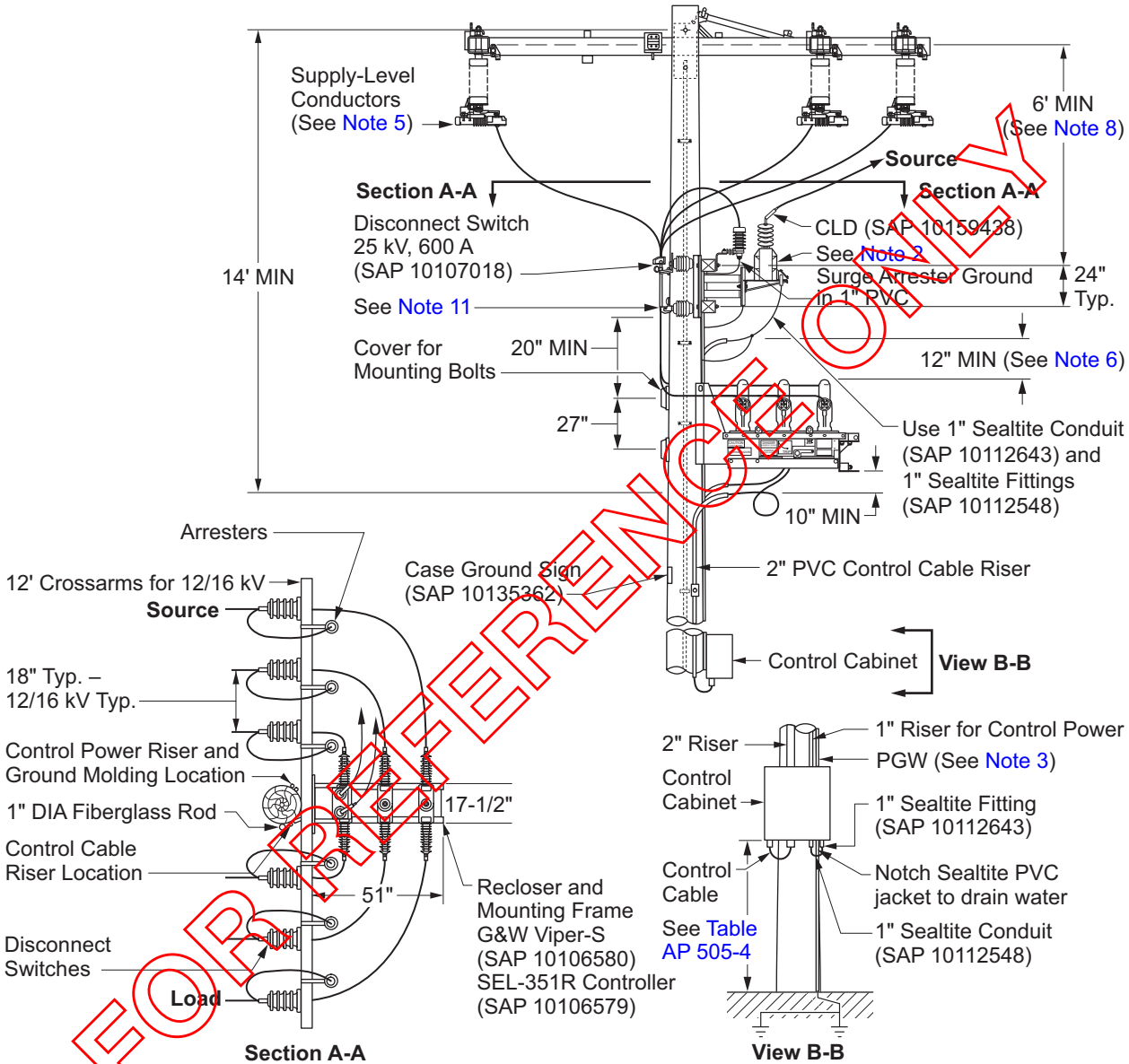

Note(s):

1. The CPT shall serve no load other than the AR and AR controls.
2. CPT to be rated 980 VA solid dielectric with 120 V fused secondary. CPT (SAP 10105102); CPT bracket (SAP 10104923) and transformer extension bracket (SAP 10067312). Do not ground the CPT bracket. See Figure AP 505-15 for details.
3. See Scope AP 505.7 for AR, control, and CPT grounding. See Scope AP 505.8 for AR, control, and CPT grounding when the CPT is mounted on an adjacent pole (alternate method). See GR 105 for ground conductor and connection requirements.

AP 505

Three Phase Overhead Electronic Reclosers (FOR REFERENCE ONLY)

Approved by:

ajf

Sheet 18 of 44

What's Changed? Standard made "FOR REFERENCE ONLY".

Effective Date:

DOH

01-25-2019

4. Install wildlife guards on all bushings and leads.
5. See [AP 336](#) for installation requirements for Omni-Rupter bypass switch, the supply conductors shall be dead-ended to the switch crossarm.
6. Maintain 12-inch minimum separation between high voltage bushings and the CPT mounting bracket, and all secondary leads.
7. See [AP 410](#) and [GR 107](#) for surge arrester installation requirements.
8. Maintain 18-inch minimum (radial) separation between CPT or arrester leads/bushings and the switch blades.
9. To provide a location for grounding at the disconnect switch terminals; leave 6-inches of uncovered conductor on the leads that terminate on the recloser.
10. Per [DC 535](#), Wildlife Protection shall be constructed and installed as applicable for insulators, taps, leads, arresters, cable terminations, and equipment bushings.
11. Use two T-Bolt connectors (2/0 AWG - 350 kcmil SAP 10110830; #6 AWG - 2/0 AWG SAP 10110829) per terminal pad to make connections at disconnect switches.
12. See [PO 120](#) for High Voltage sign installation requirements.

FOR REFERENCE ONLY

Approved by: 	Three Phase Overhead Electronic Reclosers (FOR REFERENCE ONLY)	AP 505
Effective Date: 01-25-2019	What's Changed? Standard made "FOR REFERENCE ONLY".	Sheet 19 of 44 <div style="font-size: 24px; font-weight: bold; margin-top: 5px;">DOH</div>

Figure AP 505-13: Typical G&W Viper-S Electronic ARs for 12/16 kV with the CPT Located on the Same Pole (Alternate Method Using Hughes Adapter)



AP 505

Three Phase Overhead Electronic Reclosers (FOR REFERENCE ONLY)

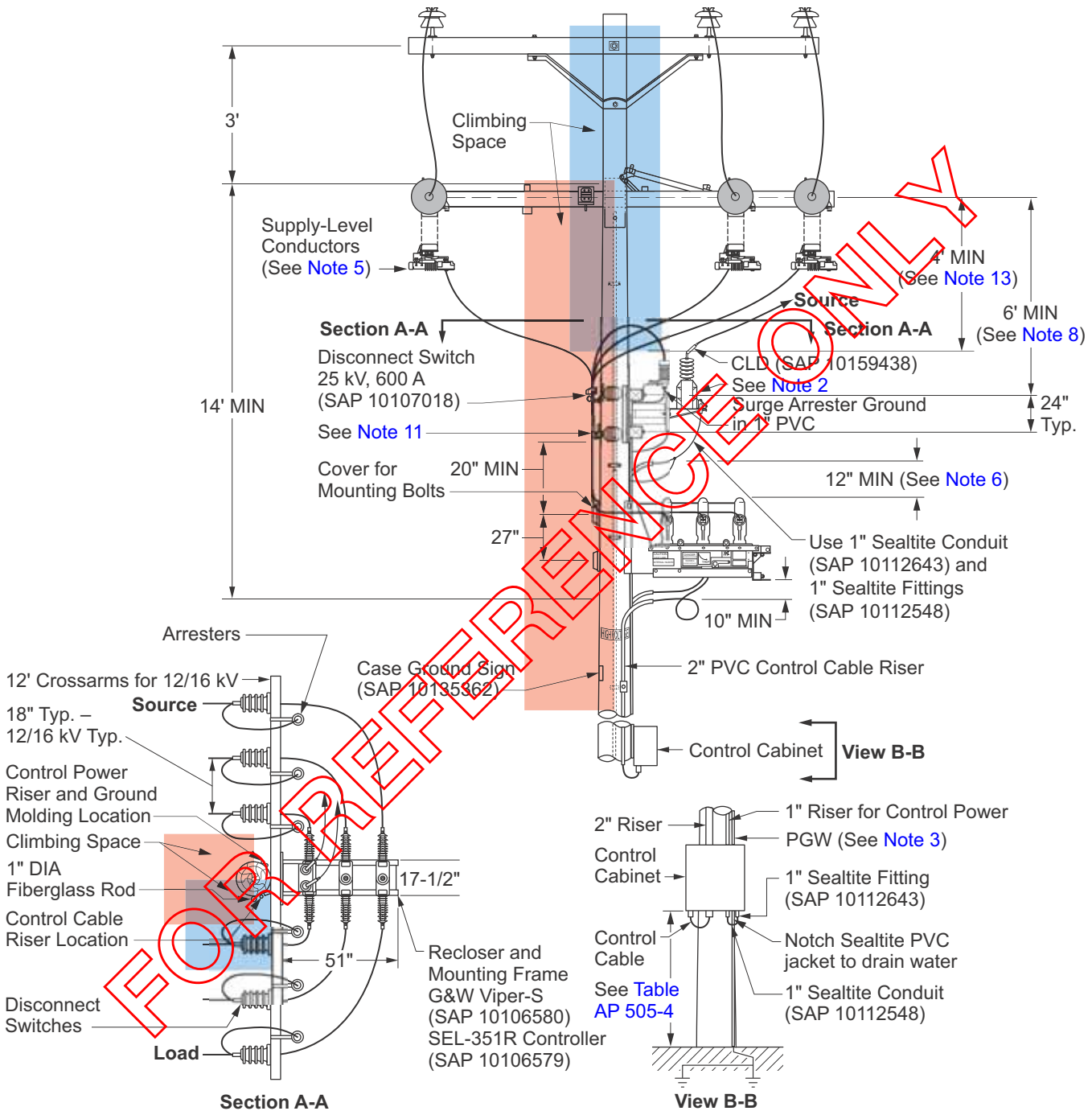
Approved by:

ajf

Sheet 20 of 44

What's Changed? Standard made "FOR REFERENCE ONLY".

Effective Date:

DOH

01-25-2019

Note(s):

1. The CPT shall serve no load other than the AR and AR controls.
2. CPT to be rated 980 VA solid dielectric with 120 V fused secondary. CPT (SAP 10105102); CPT bracket (SAP 10104923) and transformer extension bracket (SAP 10067312). Do not ground the CPT bracket. See [Figure AP 505-15](#) for details.
3. See [Scope AP 505.7](#) for AR, control, and CPT grounding. See [Scope AP 505.8](#) for AR, control, and CPT grounding when the CPT is mounted on an adjacent pole (alternate method). See [GR 105](#) for ground conductor and connection requirements.
4. Install wildlife guards on all bushings and leads.
5. See [AP 336](#) for installation requirements for Omni-Rupter bypass switch.
6. Maintain 12-inch minimum separation between high voltage bushings and the CPT mounting bracket, and all secondary leads.
7. See [AP 410](#) and [GR 107](#) for surge arrester installation requirements.
8. Maintain 18-inch minimum (radial) separation between CPT or arrester leads/bushings and the switch blades.
9. To provide a location for grounding at the disconnect switch terminals; leave 6-inches of uncovered conductor on the leads that terminate on the recloser.
10. Per [DC 535](#), Wildlife Protection shall be constructed and installed as applicable for insulators, taps, leads, arresters, cable terminations, and equipment bushings.
11. Use two T-Bolt connectors (2/0 AWG - 350 kcmil SAP 10110830; #6 AWG - 2/0 AWG SAP 10110829) per terminal pad to make connections at disconnect switches.
12. See [PO 120](#) for High Voltage sign installation requirements.
13. Taps from the Hughes adapters to disconnect switches shall be formed so as not to obstruct the required climbing space. When possible, the inside (closest to the pole) and middle disconnects should be tapped to the Omni-Rupter phases furthest from the climbing space.
14. Climbing Space required — 36" × 36".

FOR REFERENCE ONLY

Approved by: 	Three Phase Overhead Electronic Reclosers (FOR REFERENCE ONLY)	AP 505
Effective Date: 01-25-2019	What's Changed? Standard made "FOR REFERENCE ONLY".	Sheet 21 of 44 <div style="font-size: 24px; font-weight: bold; margin-top: 5px;">DOH</div>

Figure AP 505-14: G&W Viper-S 27 kV Electronic AR



Note(s):

1. Approximate weight of Automatic Recloser is 500 lb.

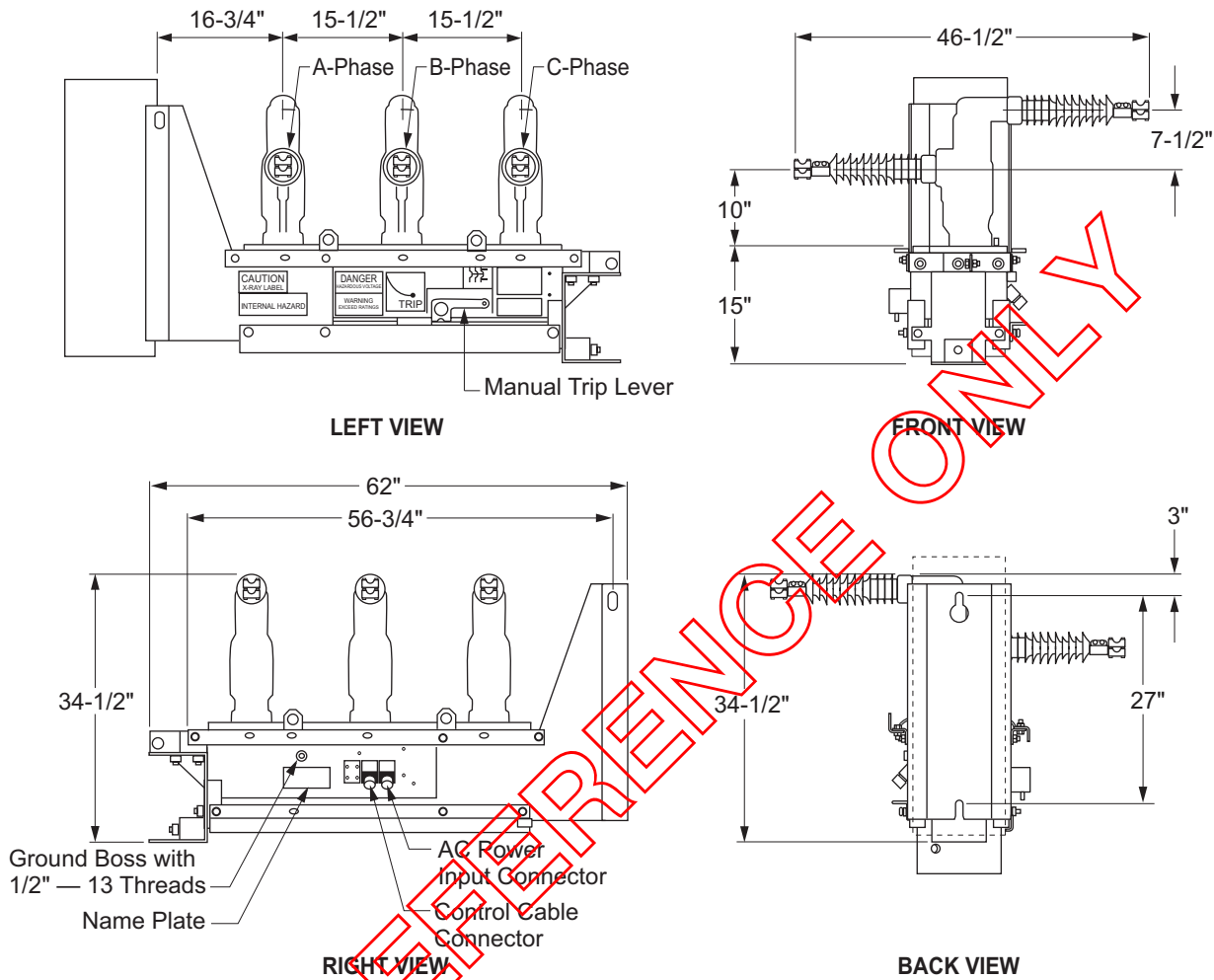
Figure AP 505-15: 12/16 kV CPT Mounting Bracket Details

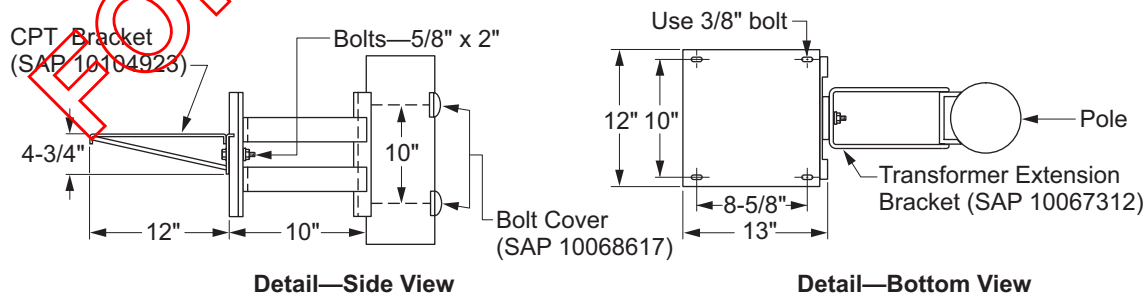

AP 505

Three Phase Overhead Electronic Reclosers (FOR REFERENCE ONLY)

Approved by:

a/j

Sheet 22 of 44

What's Changed? Standard made "FOR REFERENCE ONLY".

Effective Date:

01-25-2019

DOH

Scope AP 505.5 G&W Viper-S AR for 25 kV Installations

Figure AP 505-16: Typical G&W Viper-S Electronic ARs for 25 kV with the CPT Located on the Same Pole

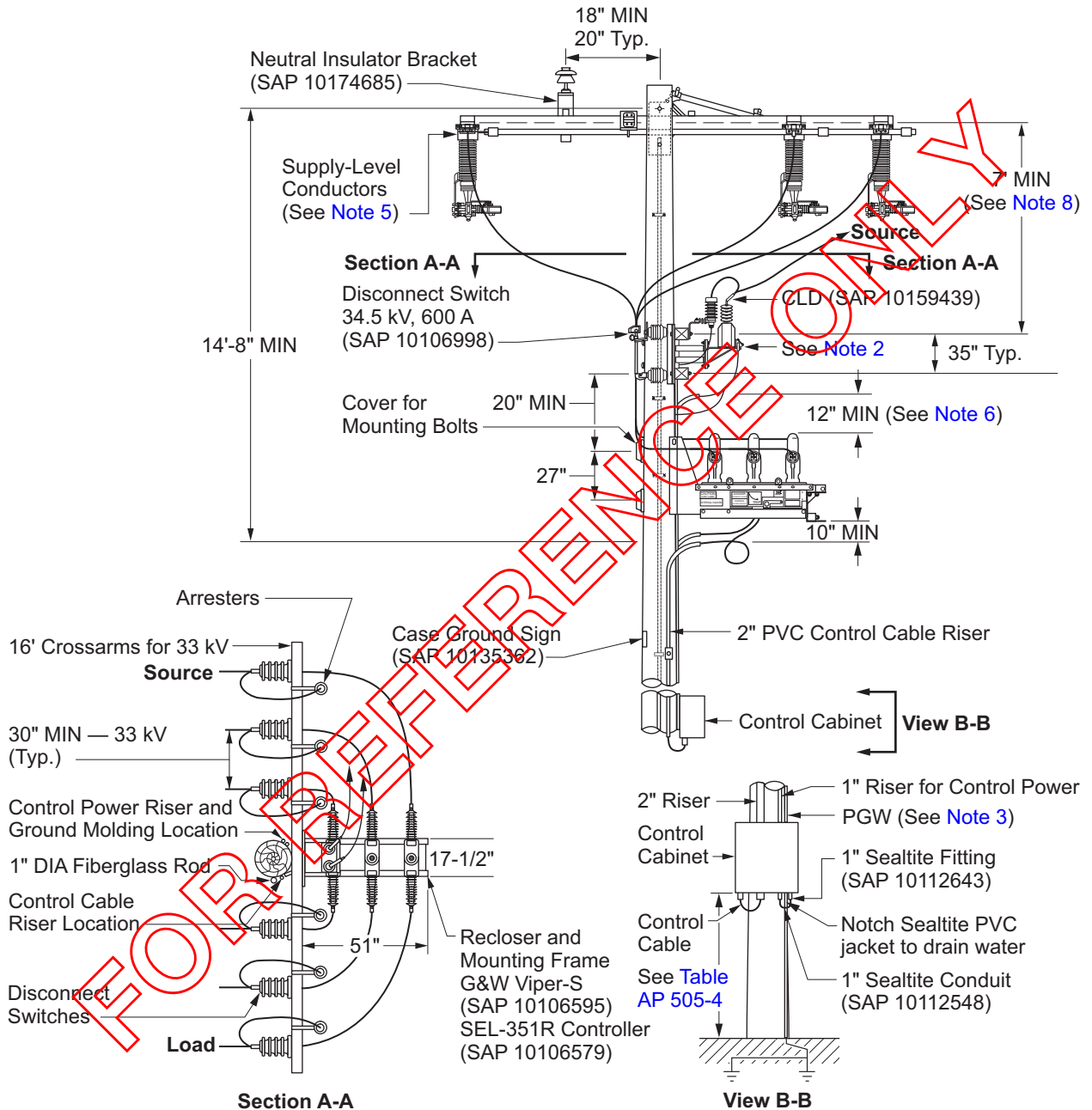

Note(s):

1. The CPT shall serve no load other than the AR and AR controls.
2. CPT to be a 1 kVA -solid dielectric with 120 V secondary (SAP 10105069); CPT (SAP 10174769) bracket and transformer extension bracket (SAP 10067312). Do not ground the CPT bracket. See Figure AP 505-18 for detail dimensions.

Approved by:

ajf

Three Phase Overhead Electronic Reclosers (FOR REFERENCE ONLY)

AP 505

Effective Date:
01-25-2019

What's Changed? Standard made "FOR REFERENCE ONLY".

Sheet 23 of 44

DOH

3. See [Scope AP 505.7](#) for AR, control, and CPT grounding. See [Scope AP 505.8](#) for AR, control, and CPT grounding when the CPT is mounted on an adjacent pole (alternate method). See [GR 105](#) for ground conductor and connection requirements.
4. Install wildlife guards on all bushings and leads.
5. See [AP 338](#) for installation requirements for Alduti-Rupter bypass switch, the supply conductors shall be dead-ended to the switch crossarm.
6. Maintain 12-inch minimum separation between high voltage bushings and the CPT mounting bracket, and all secondary leads.
7. See [AP 410](#) and [GR 107](#) for surge arrester installation requirements.
8. Maintain a 24-inch minimum (radial) separation between CPT or arrester leads/bushings and the switch blades.
9. To provide a location for grounding at the disconnect switch terminals; leave 6-inches of uncovered conductor on the leads that terminate on the recloser.
10. Per [DC 535](#), Wildlife Protection shall be constructed and installed as applicable for insulators, taps, leads, arresters, cable terminations, and equipment bushings.

Figure AP 505-17: G&W Viper-S 38 kV Electronic AR

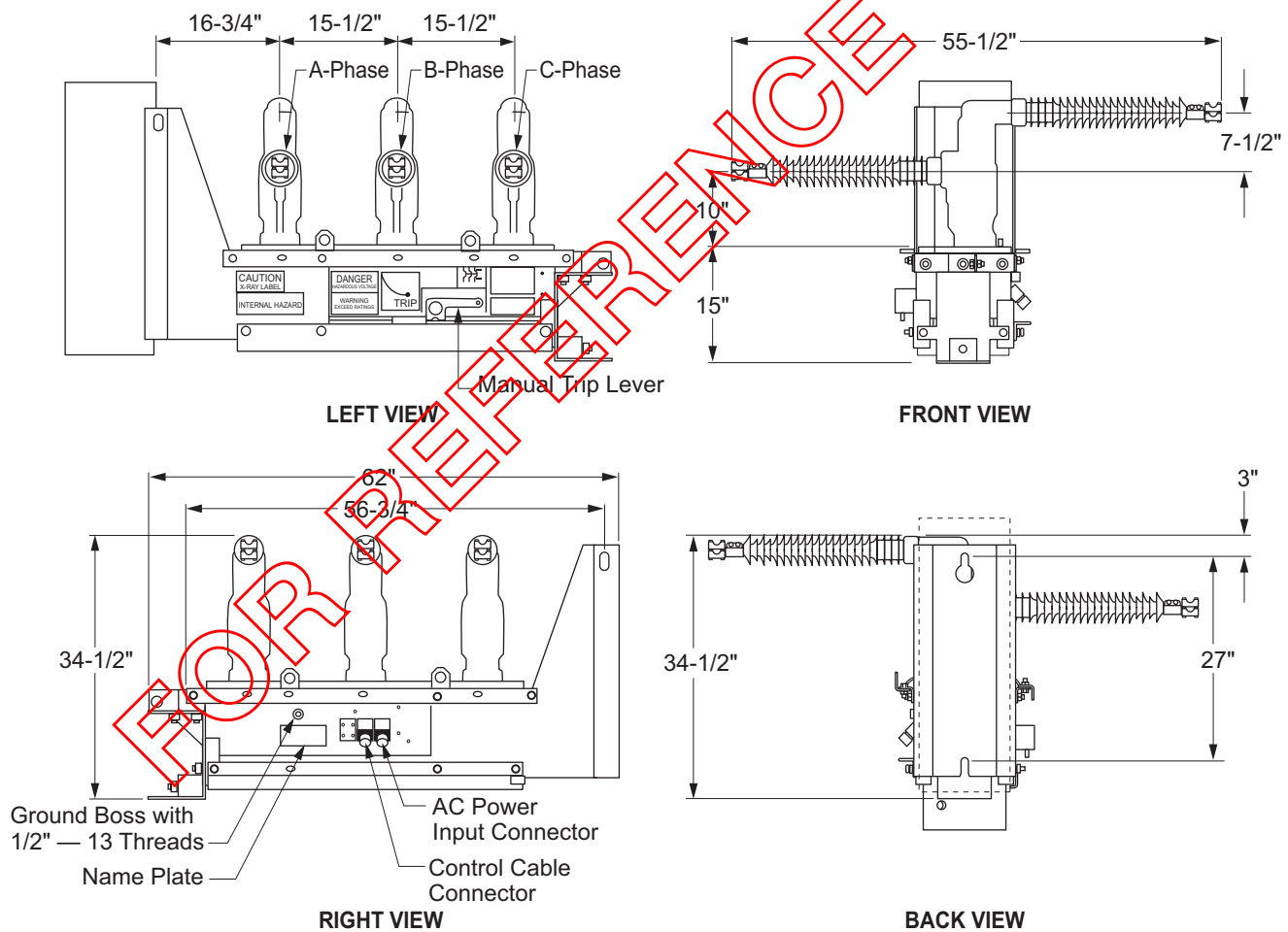

Note(s):

1. Approximate weight of Automatic Recloser is 600 lb.

AP 505

Three Phase Overhead Electronic Reclosers (FOR REFERENCE ONLY)

Approved by:

a/j

Sheet 24 of 44

What's Changed? Standard made "FOR REFERENCE ONLY".

Effective Date:

DOH

01-25-2019

Figure AP 505-18: 25 kV CPT Mounting Bracket Details

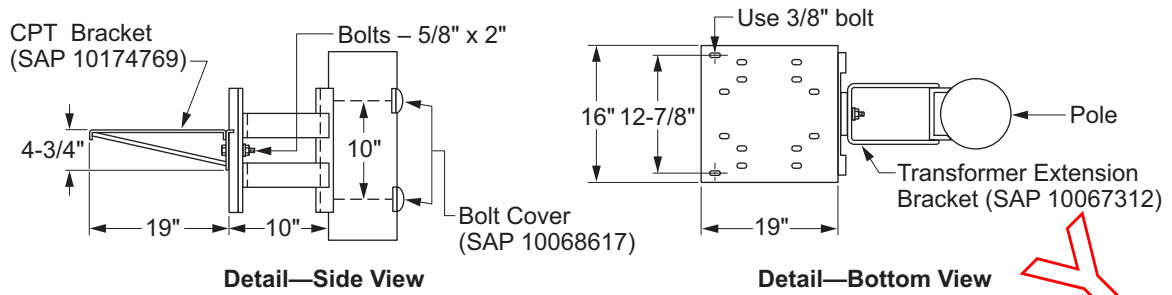
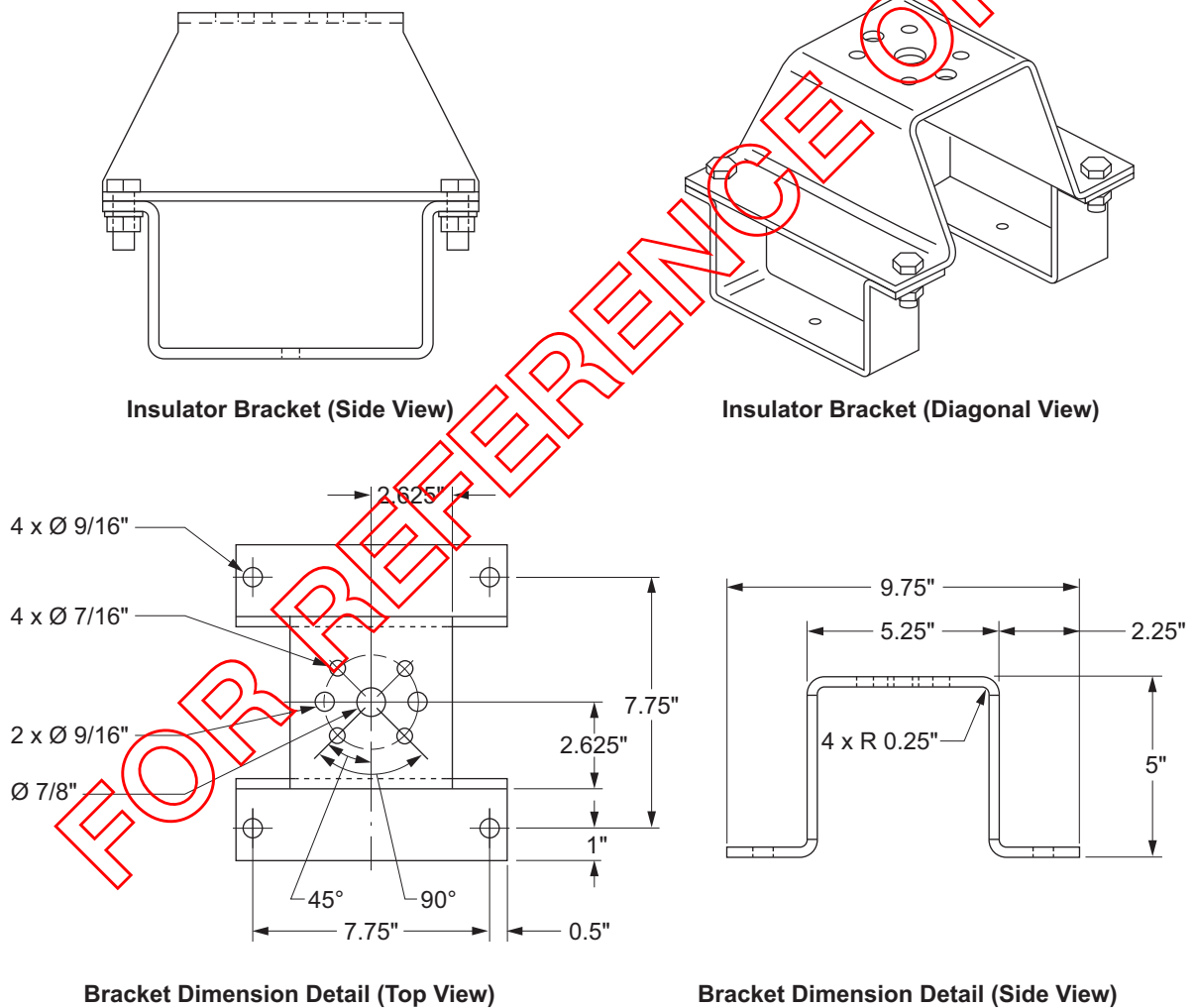

Figure AP 505-19: Insulator Mounting Bracket for 25 kV Installations



FOR REFERENCE ONLY

Approved by:

ajf

Three Phase Overhead Electronic Reclosers (FOR REFERENCE ONLY)

AP 505

Effective Date:

01-25-2019

What's Changed? Standard made "FOR REFERENCE ONLY".

Sheet 25 of 44

DOH

Scope AP 505.6 G&W Viper-S AR for 33 kV Installations

Figure AP 505-20: Typical G&W Viper-S Electronic ARs for 33 kV with the CPT Located on the Same Pole

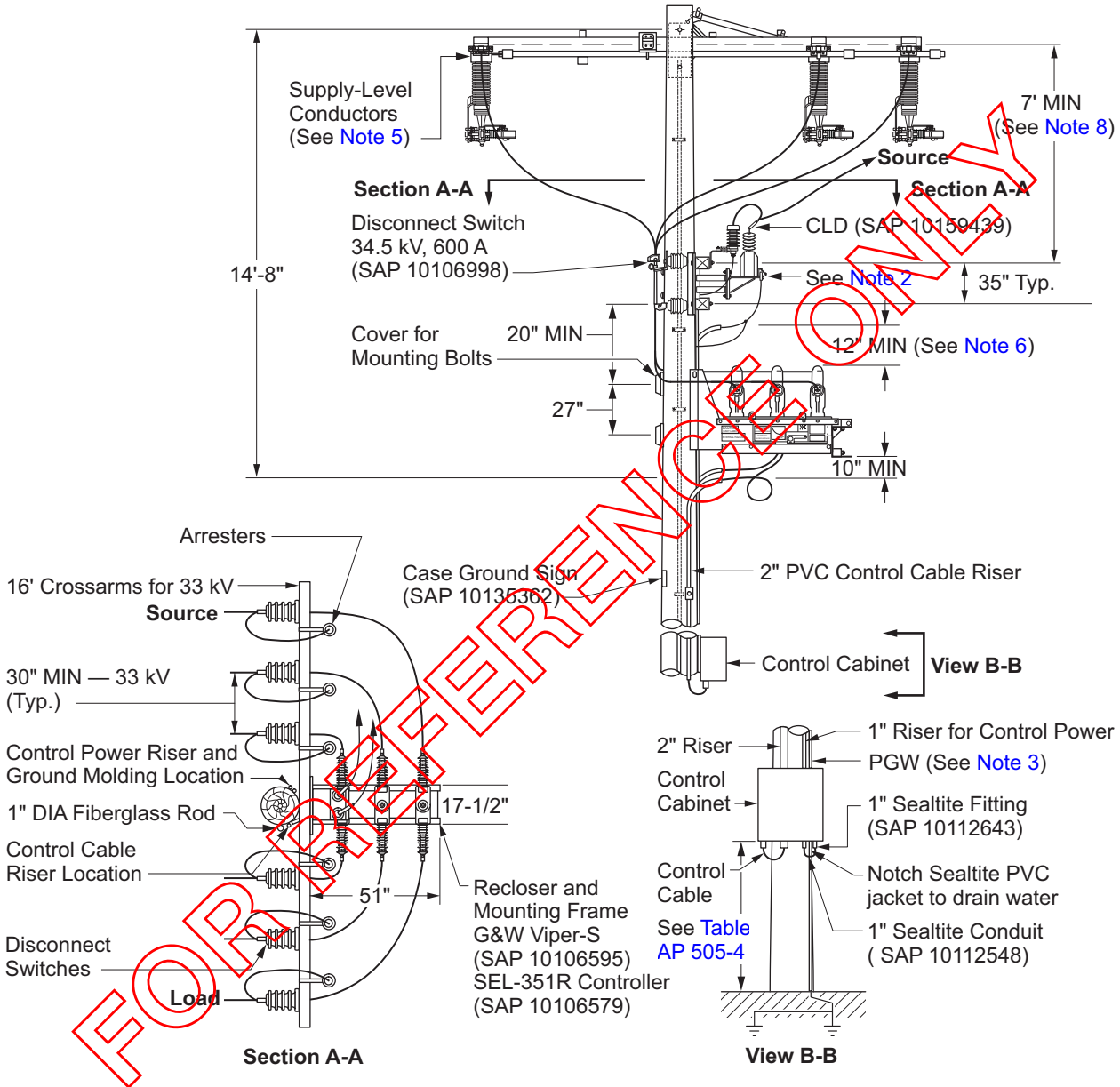

Note(s):

1. The CPT shall serve no load other than the AR and AR controls.
2. CPT to be a 1 kVA -solid dielectric with 120 V fused secondary. CPT (SAP 10167672), CPT bracket (SAP 10067317), CPT extension bracket (SAP 10067312).
3. See [Scope AP 505.7](#) for AR, control, and CPT grounding. See [Scope AP 505.8](#) for AR, control, and CPT grounding when the CPT is mounted on an adjacent pole (alternate method). See [GR 105](#) for ground conductor and connection requirements.

AP 505

Three Phase Overhead Electronic Reclosers (FOR REFERENCE ONLY)

Approved by:

a/j

Sheet 26 of 44

What's Changed? Standard made "FOR REFERENCE ONLY".

Effective Date:

DOH

01-25-2019

4. Install wildlife guards on all bushings and leads.
5. See AP 338 for installation requirements for Alduti-Rupter bypass switch, the supply conductors shall be dead-ended to the switch crossarm.
6. Maintain 12-inch minimum separation between high voltage bushings and the CPT mounting bracket, and all secondary leads.
7. See AP 410 and GR 107 for surge arrester installation requirements.
8. Maintain a 24-inch minimum (radial) separation between CPT or arrester leads/bushings and the switch blades.
9. To provide a location for grounding at the disconnect switch terminals; leave 6-inches of uncovered conductor on the leads that terminate on the recloser
10. Per DC 535, Wildlife Protection shall be constructed and installed as applicable for insulators, taps, leads, arresters, cable terminations, and equipment bushings.

Figure AP 505-21: G&W Viper-S 38 kV Electronic AR

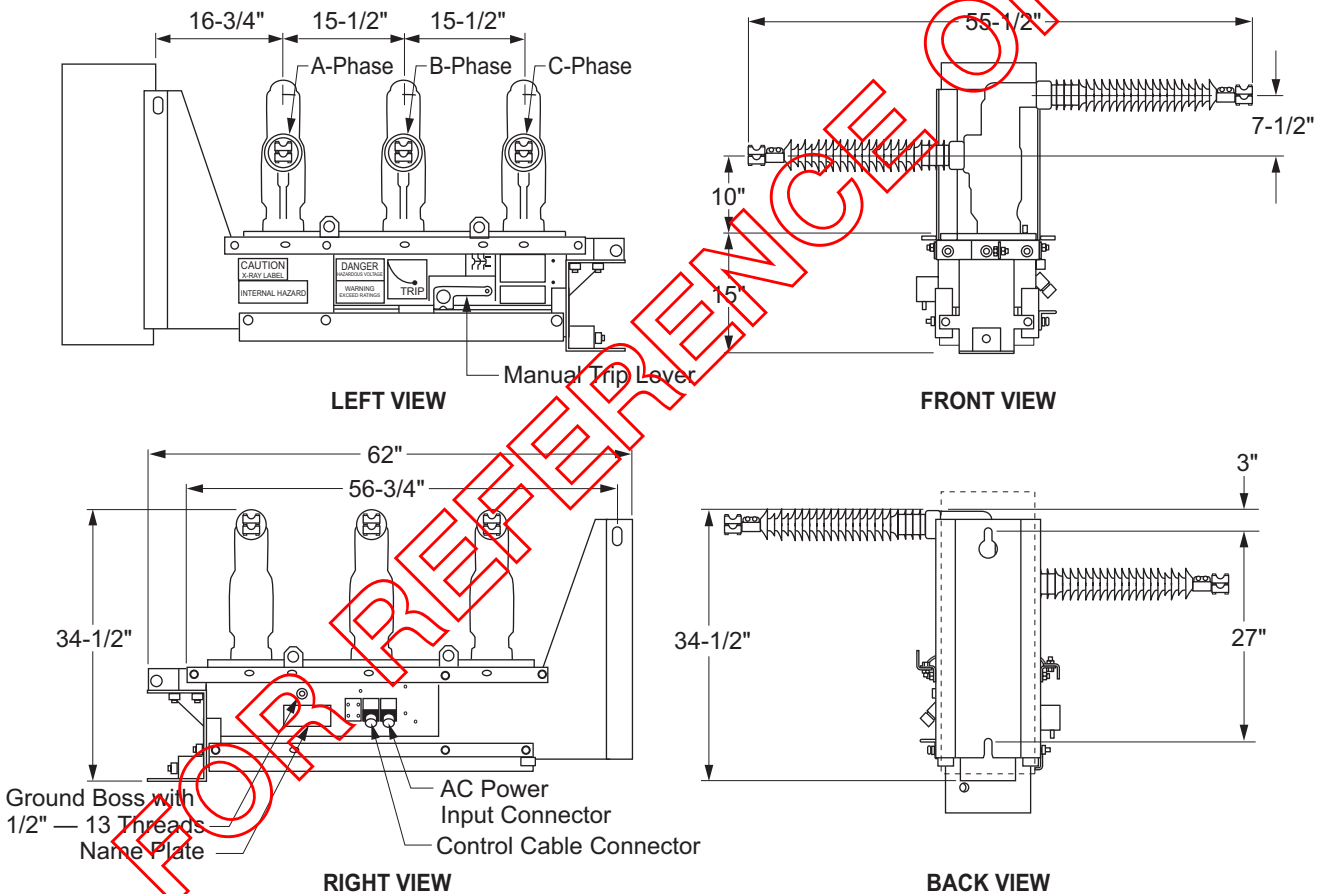

Note(s):

1. Approximate weight of Automatic Recloser is 600 lb.

Approved by: <i>ajf</i>	Three Phase Overhead Electronic Reclosers (FOR REFERENCE ONLY)	AP 505
Effective Date: 01-25-2019	What's Changed? Standard made "FOR REFERENCE ONLY".	Sheet 27 of 44
		DOH

Figure AP 505–22: 33 kV CPT Mounting Bracket Details

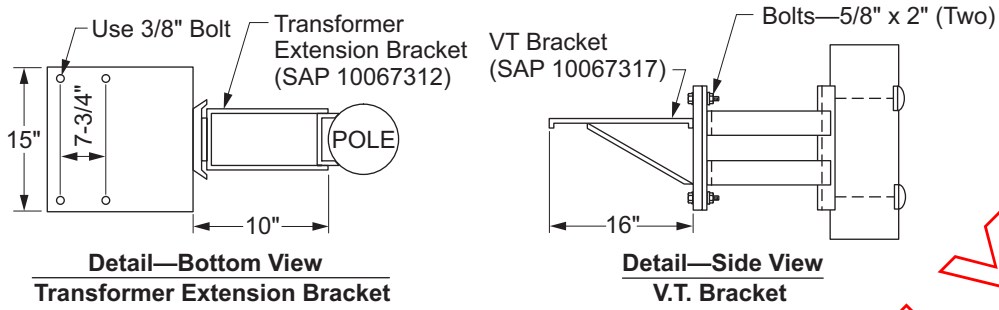

FOR REFERENCE ONLY

Scope AP 505.7 Typical AR Connections with the CPT Located on the Same Pole (Preferred Method)

Figure AP 505-23: Typical Connections for G&W Viper-S, McGraw-Edison Type WE, NOVA, and WVE38X Electronic ARs with the CPT Located on the Same Pole (Preferred Method)

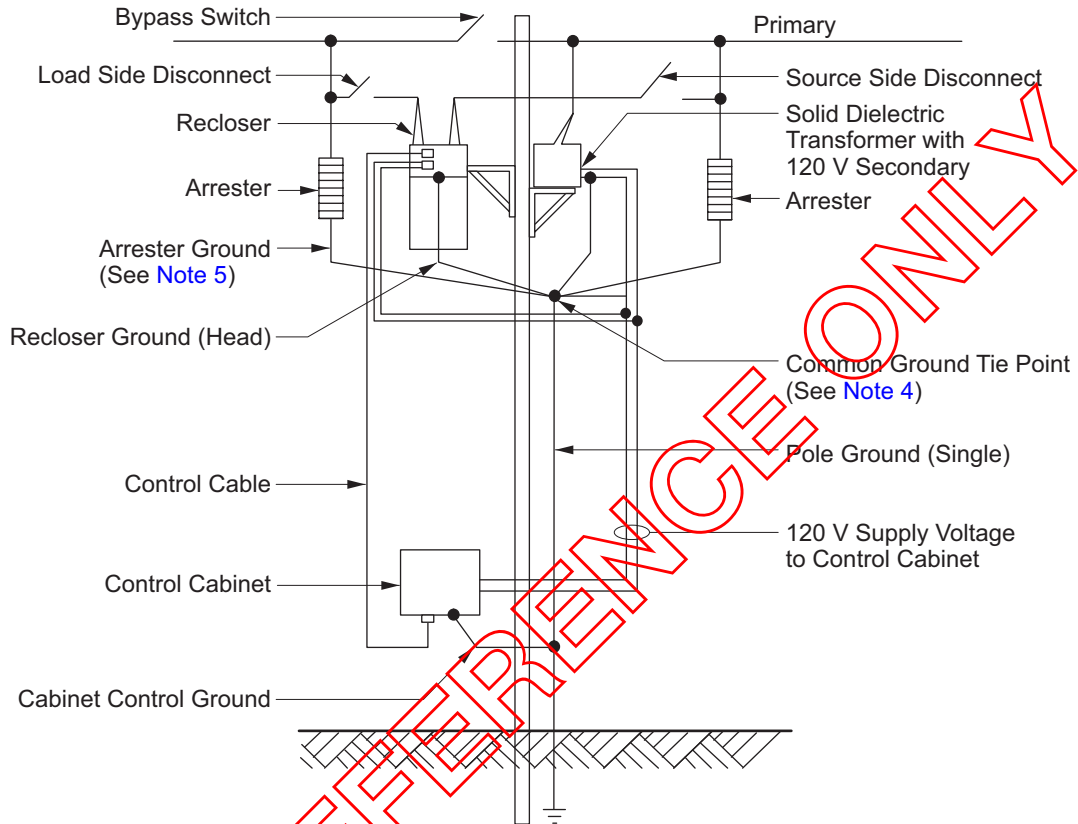

Note(s):

1. The CPT shall serve no load other than the AR and AR control.
2. Control cable shielding shall be grounded to the AR head and to the control cabinet.
3. AR primary bushings are denoted "line" and "load". This is only applicable to ARs with high voltage closing coils. Either side can be used for source or load with WE ARs, NOVA ARs, and Viper ARs.
4. Surge arresters, transformer tank discharge gap, secondary neutral, AR tank and frame, and control cabinet shall be connected to the same ground to minimize any potential ground differences between equipment.
5. Each surge arresters ground lead shall be connected to a bare copper ground wire in PVC on the bottom of the mounting crossarm. Notch the PVC to allow room for the Kearny connector for the arrester ground lead connection. Protected Ground Wire (PGW) may be applied as the arrester ground without the use of PVC conduit on the pole, see [GR Section](#) for details. Bare copper ground wires must be installed in PVC conduit. Maintain proper clearance between the ground and bond or bonded equipment.
6. Depending on the vintage of the installation, the CPT may be a solid dielectric transformer or conventional oil-filled transformer with 120/240 V secondary. All CPT installations shall be protected by surge arresters. Conventional oil-filled transformers shall be protected by a tank discharge gap (SAP 10109298).
7. Per [DC 535](#), Wildlife Protection shall be constructed and installed as applicable for insulators, taps, leads, arresters, cable terminations, and equipment bushings.

Approved by: <i>ajf</i>	Three Phase Overhead Electronic Reclosers (FOR REFERENCE ONLY)	AP 505
Effective Date: 01-25-2019	What's Changed? Standard made "FOR REFERENCE ONLY".	Sheet 29 of 44 DOH

Scope AP 505.8 Typical AR Connections with the Solid Dielectric CPT Located on a Separate Pole (Alternate Method)

Figure AP 505-24: Typical Connections for G&W Viper-S, McGraw-Edison Type WE, NOVA, and WVE38X Electronic ARs with the CPT Located on a Separate Pole (Alternate Method)

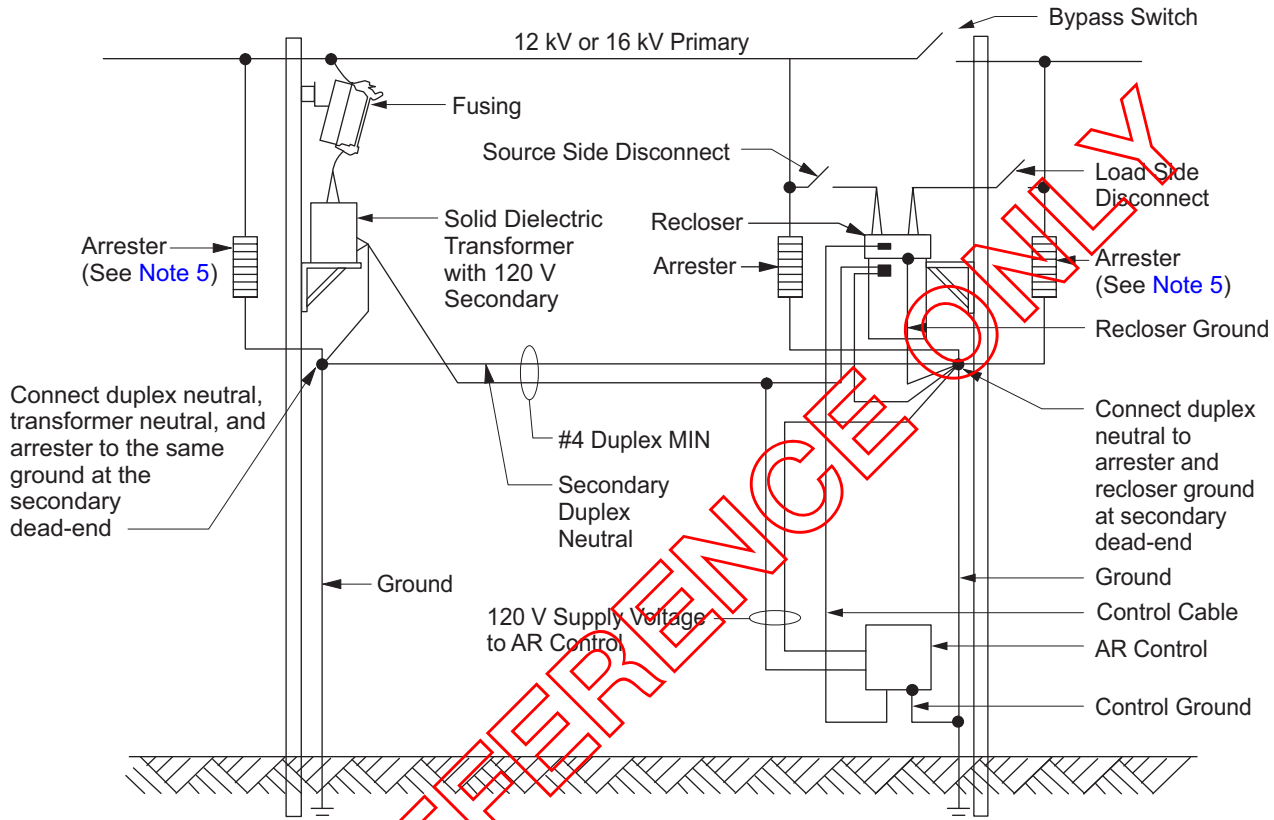

Note(s):

1. The CPT shall serve no load other than the AR and AR control.
2. Control cable shielding shall be grounded to the AR head and to the control cabinet.
3. AR primary bushings are denoted "line" and "load". This is only applicable to ARs with high voltage closing coils. Either side can be used for source or load with WE ARs, NOVA ARs, and Viper ARs.
4. Surge arresters, transformer tank gap, AR tank and frame, and control cabinet grounds shall be connected through the secondary neutral to minimize and potential ground differences between equipment.
5. Each surge arresters ground lead shall be connected to a bare copper ground wire in PVC on the bottom of the mounting crossarm. Notch the PVC to allow room for the Kearny connector for the arrester ground lead connection. Protected Ground Wire (PGW) may be applied as the arrester ground without the use of PVC conduit on the pole, see [GR Section](#) for details. Bare copper ground wires must be installed in PVC conduit. Maintain proper clearance between the ground and bond or bonded equipment.
6. Depending on the vintage of the installation, the CPT may be a solid dielectric transformer or conventional oil-filled transformer with 120/240 V secondary. All CPT installations shall be protected by surge arresters. Conventional oil-filled transformers shall be protected by a tank discharge gap (SAP 10109298).
7. Per [DC 535](#), Wildlife Protection shall be constructed and installed as applicable for insulators, taps, leads, arresters, cable terminations, and equipment bushings.

AP 505

Three Phase Overhead Electronic Reclosers (FOR REFERENCE ONLY)

Approved by:

a/j

Sheet 30 of 44

What's Changed? Standard made "FOR REFERENCE ONLY".

Effective Date:

DOH

01-25-2019

Scope AP 505.9 Wiring Diagram for Titan 75LC Surge Suppressor for SEL351R

Figure AP 505–25: Wiring Diagram for Titan 75LC Surge Suppressor for SEL351R

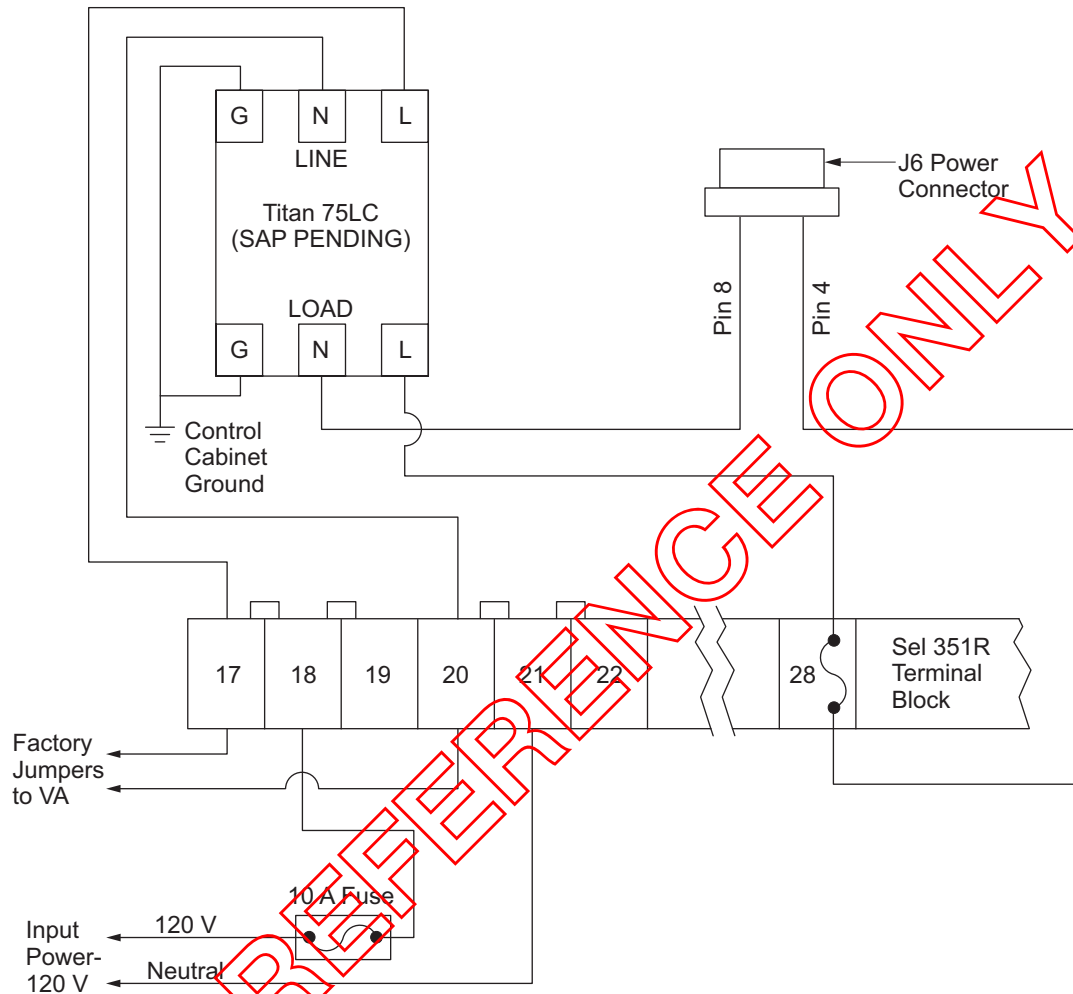

Note(s):

1. The Titan 75LC Surge Suppressor may be used to prevent nuisance operations of the battery charger fuse located at Terminal Block (TB) 28.

Approved by:

ajf

Three Phase Overhead Electronic Reclosers (FOR REFERENCE ONLY)

AP 505

Effective Date:
01-25-2019

What's Changed? Standard made "FOR REFERENCE ONLY".

Sheet 31 of 44

DOH

Scope AP 505.10 Typical G&W Viper 12/16 kV Electronic ARs with the CPT Located on the Same Pole (Preferred Method)

Figure AP 505-26: Typical G&W Viper 12/16 kV Electronic ARs with the CPT Located on the Same Pole (Preferred Method)

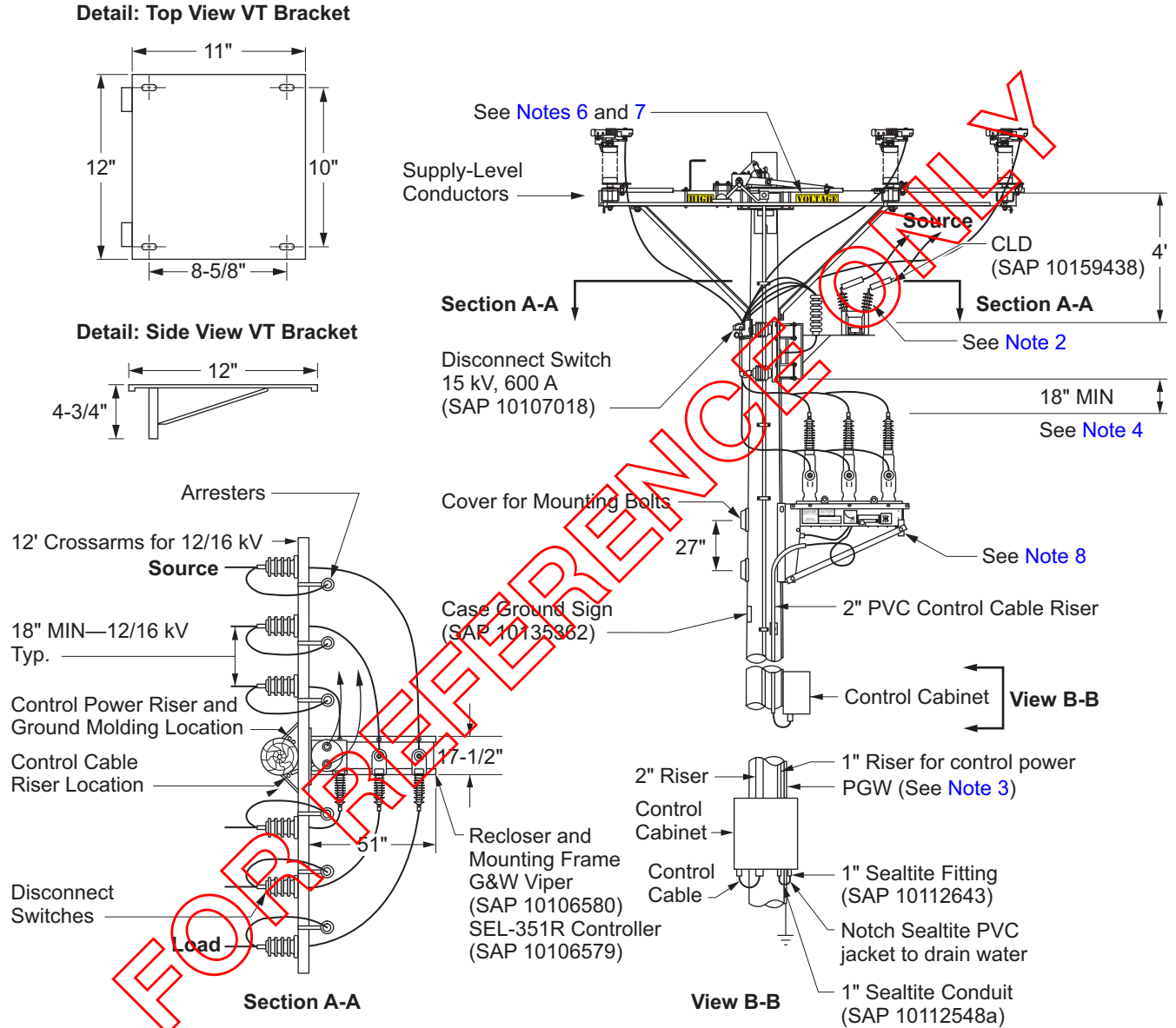

Note(s):

1. The CPT shall serve no load other than the AR and AR controls.
2. CPT to be a 980 VA-fused solid dielectric transformer with 120 V secondary. Transformer to be protected by surge arresters—transformer (SAP 10105102); transformer bracket (SAP 10104923).
3. See [Scope AP 505.9](#) for recloser, control, and transformer grounding. See [Scope AP 505.11](#) for recloser, control, and transformer grounding when the transformer is mounted on an adjacent pole (alternate method). See [GR 105](#) for ground conductor and connection requirements.

4. When replacing an existing AR the conventional oil-filled transformer and crossarms may not need to be disturbed. In these cases, this dimension shall be set to maintain a 12-inch clearance between the high voltage bushings and leads with the transformer tank and secondary leads.
5. Install wildlife guards on all bushings and leads.
6. HIGH VOLTAGE signs mounted on crossarms are for existing installations only. For new or replacement of HIGH VOLTAGE sign installations, see [PO 120](#).
7. For maintenance purposes, deteriorated HIGH VOLTAGE signs on crossarms shall be removed when work permits. Refer to Distribution Operations Maintenance Policies and Procedures (DOM) Manual, Chapter IM-2.
8. See [Figure AP 505-27](#) for dimensions of the 12/16 kV Viper AR.
9. Per [DC 535](#), Wildlife Protection shall be constructed and installed as applicable for insulators, taps, leads, arresters, cable terminations, and equipment bushings.

Figure AP 505-27: G&W Viper 12/16 kV Electronic AR

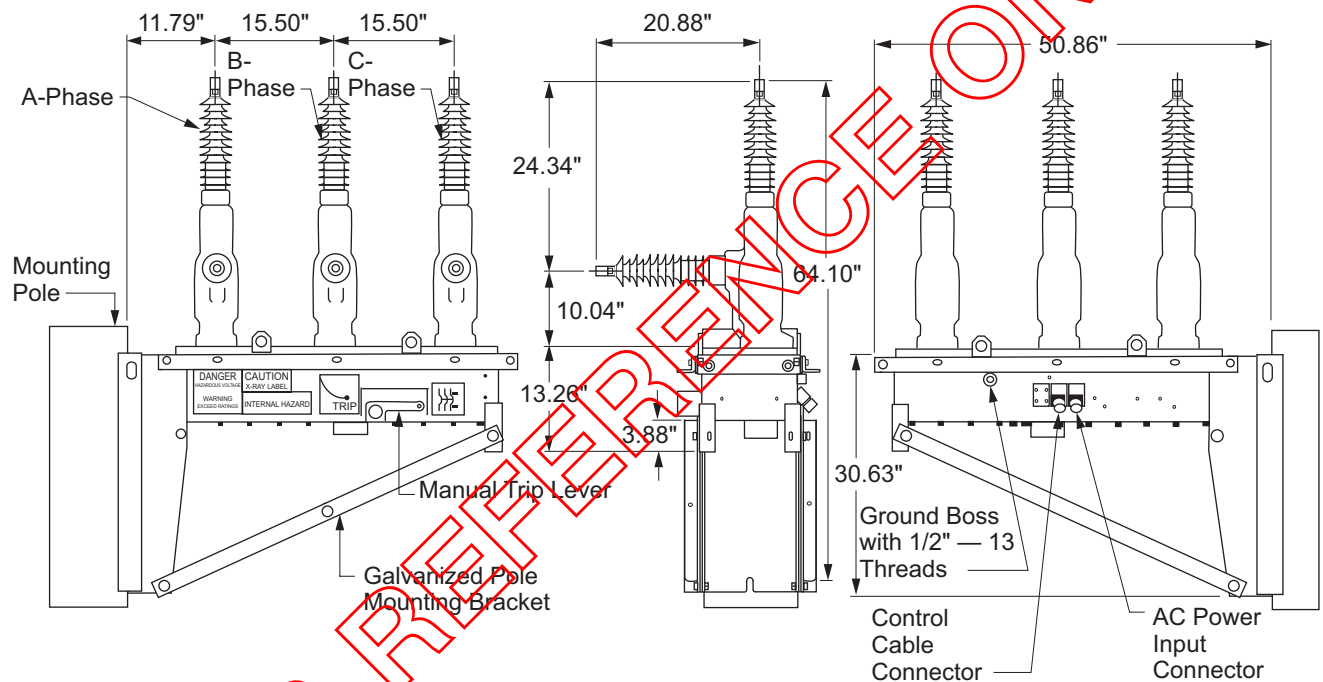

Note(s):

1. G&W Viper 12/16 kV Electronic AR (SAP 10106580).

Approved by: <i>ajt</i>	Three Phase Overhead Electronic Reclosers (FOR REFERENCE ONLY)	AP 505
Effective Date: 01-25-2019	What's Changed? Standard made "FOR REFERENCE ONLY".	Sheet 33 of 44 DOH

Scope AP 505.11 Typical Cooper (McGraw-Edison) Type WE and NOVA 12/16 kV Electronic ARs with the CPT Located on the Same Pole

Figure AP 505-28: Typical Cooper (McGraw-Edison) Type WE and NOVA 12/16 kV Electronic ARs with the CPT Located on the Same Pole

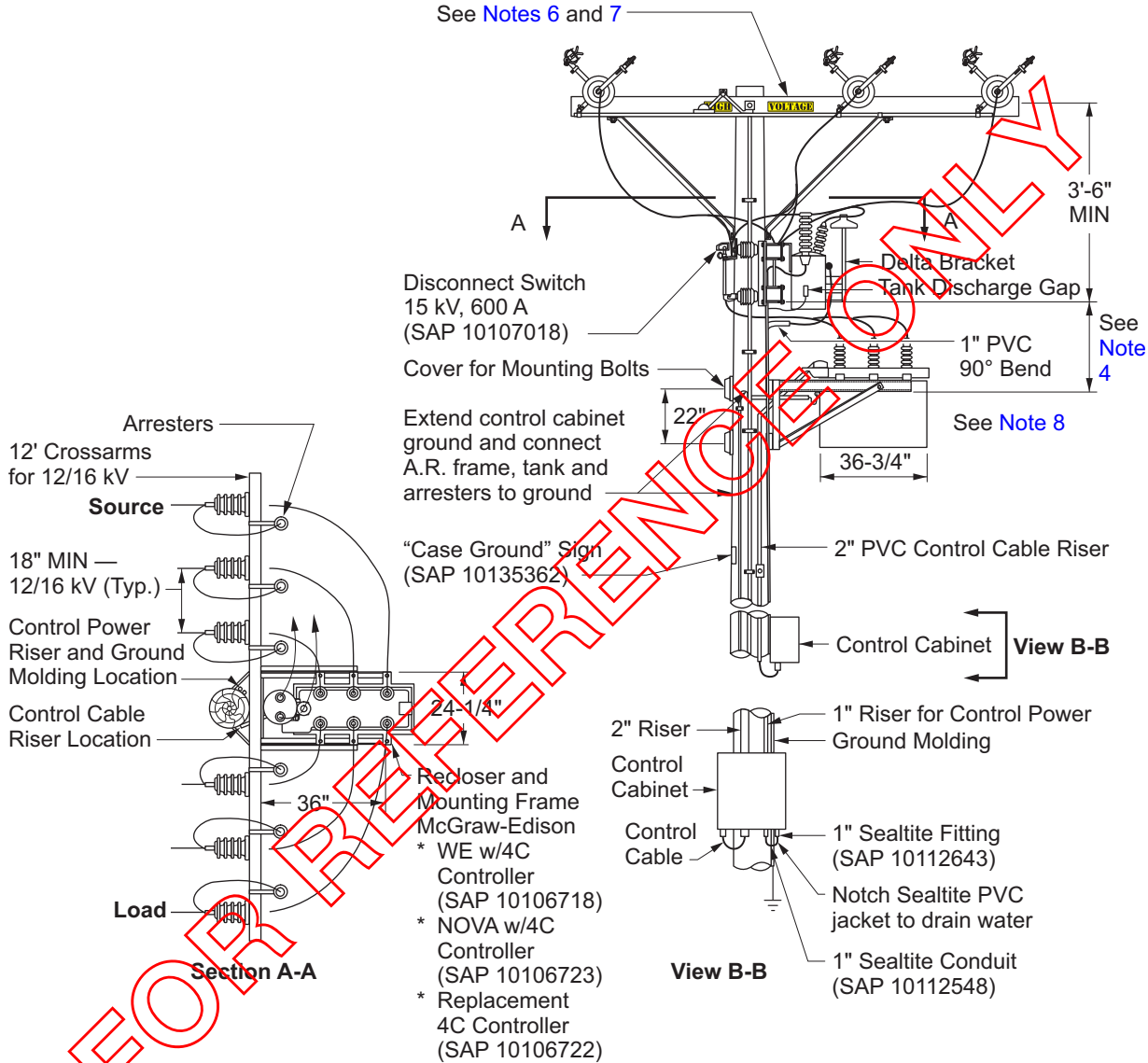

Note(s):

1. The CPT shall serve no load other than the AR and AR controls.
2. CRT to be a 5 kVA nonfused conventional transformer with 120/240 V secondary. Transformer to be protected by surge arresters and tank discharge gap. A 980 VA solid dielectric transformer may be used for replacing the conventional transformer. See AP 505.1 for specific requirements.
3. See Scope AP 505.9 for AR, control, and transformer grounding. See Scope AP 505.11 for AR, control, and transformer grounding when the transformer is mounted on an adjacent pole (alternate method). See GR 105 for ground conductor and connection requirements.

AP 505

Three Phase Overhead Electronic Reclosers (FOR REFERENCE ONLY)

Approved by:

ajf

Sheet 34 of 44

What's Changed? Standard made "FOR REFERENCE ONLY".

Effective Date:

DOH

01-25-2019

4. Set this dimension to maintain a 12-inch minimum between high voltage bushings and leads, and the transformer tank and secondary leads.
5. Install wildlife guards on all bushings and leads.
6. HIGH VOLTAGE signs mounted on crossarms are for existing installations only. For new or replacement of HIGH VOLTAGE sign installations, see [PO 120](#).
7. For maintenance purposes, deteriorated HIGH VOLTAGE signs on crossarms shall be removed when work permits. Refer to DOM, Chapter IM-2.
8. See [Figure AP 505-14](#) for NOVA dimensions.
9. Per [DC 535](#), Wildlife Protection shall be constructed and installed as applicable for insulators, taps, leads, arresters, cable terminations, and equipment bushings.

Figure AP 505-29: Cooper NOVA 12/16 kV Electronic AR

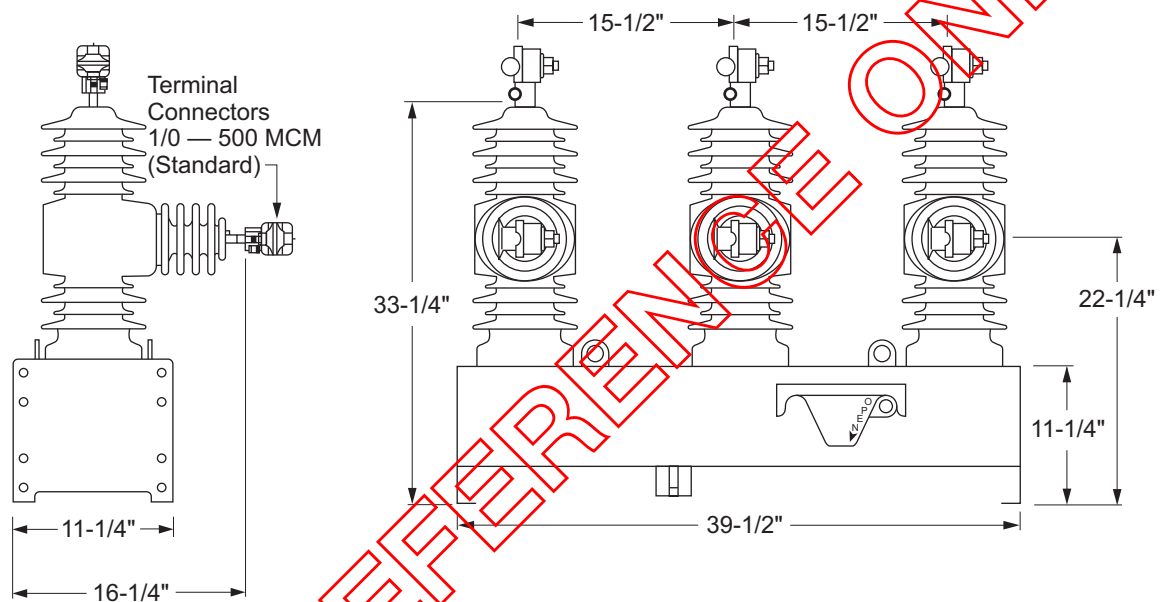

Note(s):

1. Cooper NOVA 12/16 kV Electronic AR and control (SAP 10106723).
2. Cooper NOVA 12/16 kV Electronic AR (SAP 10159244).

Approved by: <i>ajf</i>	Three Phase Overhead Electronic Reclosers (FOR REFERENCE ONLY)	AP 505
Effective Date: 01-25-2019	What's Changed? Standard made "FOR REFERENCE ONLY".	Sheet 35 of 44
		DOH

Scope AP 505.12 Typical G&W Viper 38 kV Electronic AR with the CPT Located on the Same Pole (Preferred Method)

Figure AP 505-30: Typical G&W Viper 38 kV Electronic AR with the CPT Located on the Same Pole (Preferred Method)

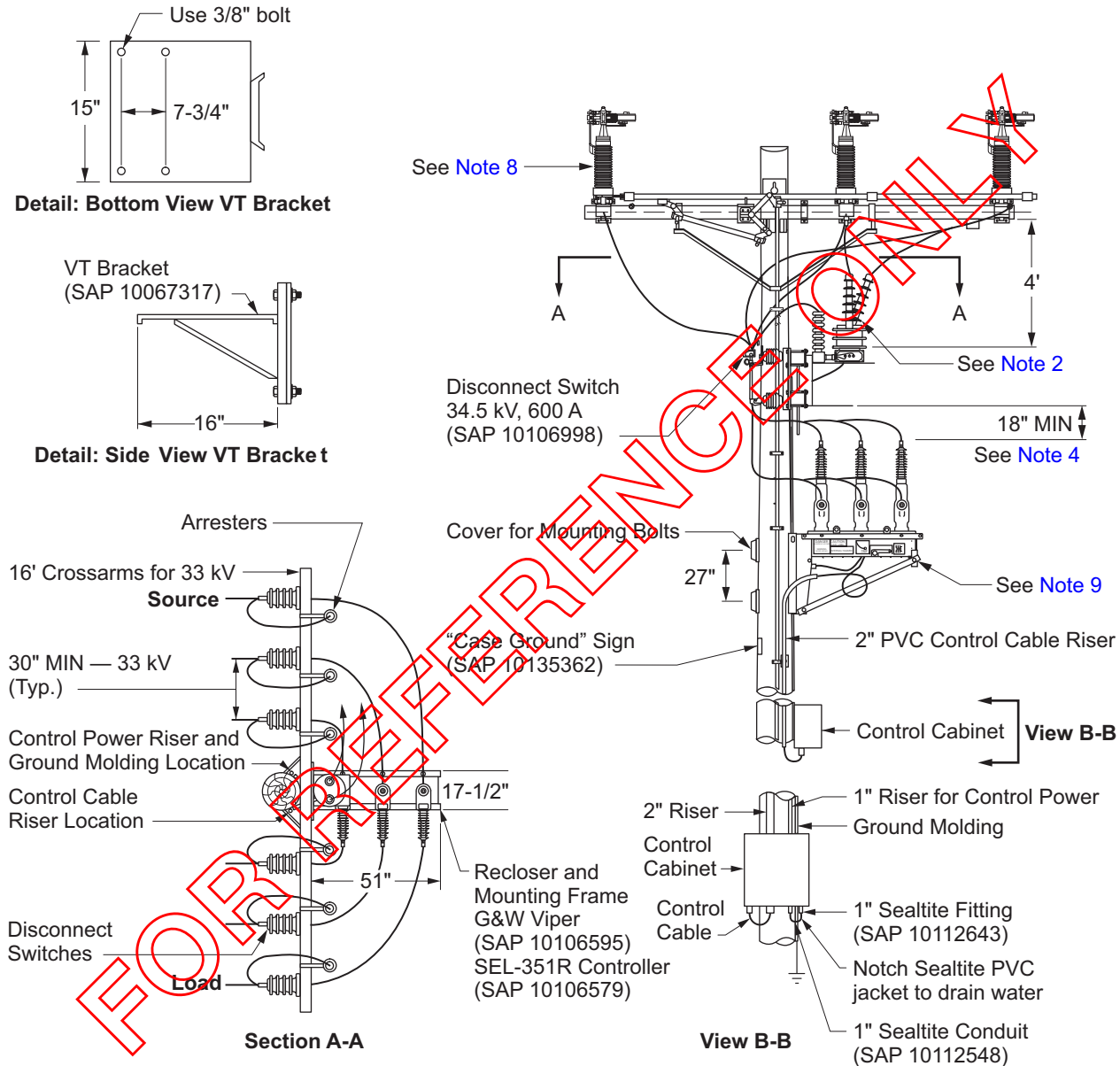

Note(s):

1. The CPT shall serve no load other than the AR and AR controls.
2. CRT for the Viper is a 1 kVA solid dielectric VT with a 120 V secondary (SAP 10167672).
3. See [Scope AP 505.9](#) for AR, control, and transformer grounding. See [Scope AP 505.11](#) for AR, control, and transformer grounding when the transformer is mounted on an adjacent pole (alternate method). See [GR 105](#) for ground conductor and connection requirements.

AP 505

Three Phase Overhead Electronic Reclosers (FOR REFERENCE ONLY)

Approved by:

ajf

Sheet 36 of 44

What's Changed? Standard made "FOR REFERENCE ONLY".

Effective Date:

DOH

01-25-2019

4. When replacing an existing AR the conventional oil-filled transformer and crossarms may not need to be disturbed. In these cases this dimension shall be set to maintain a 12-inch clearance between the high voltage bushings and leads with the transformer tank and secondary leads.
5. Install wildlife guards on all bushings and leads.
6. HIGH VOLTAGE signs mounted on crossarms are for existing installations only. For new or replacement of HIGH VOLTAGE sign installations, see [PO 120](#).
7. For maintenance purposes, deteriorated HIGH VOLTAGE signs on crossarms shall be removed when work permits. Refer to DOM, Chapter IM-2.
8. See [AP 338](#) for installation requirements for the Alduti-Rupter bypass switch.
9. See [Figure AP 505-24](#) for dimensions of the 38 kV Viper AR.
10. Per [DC 535](#), Wildlife Protection shall be constructed and installed as applicable for insulators, taps, leads, arresters, cable terminations, and equipment bushings.

Figure AP 505-31: G&W Viper 38 kV Electronic AR

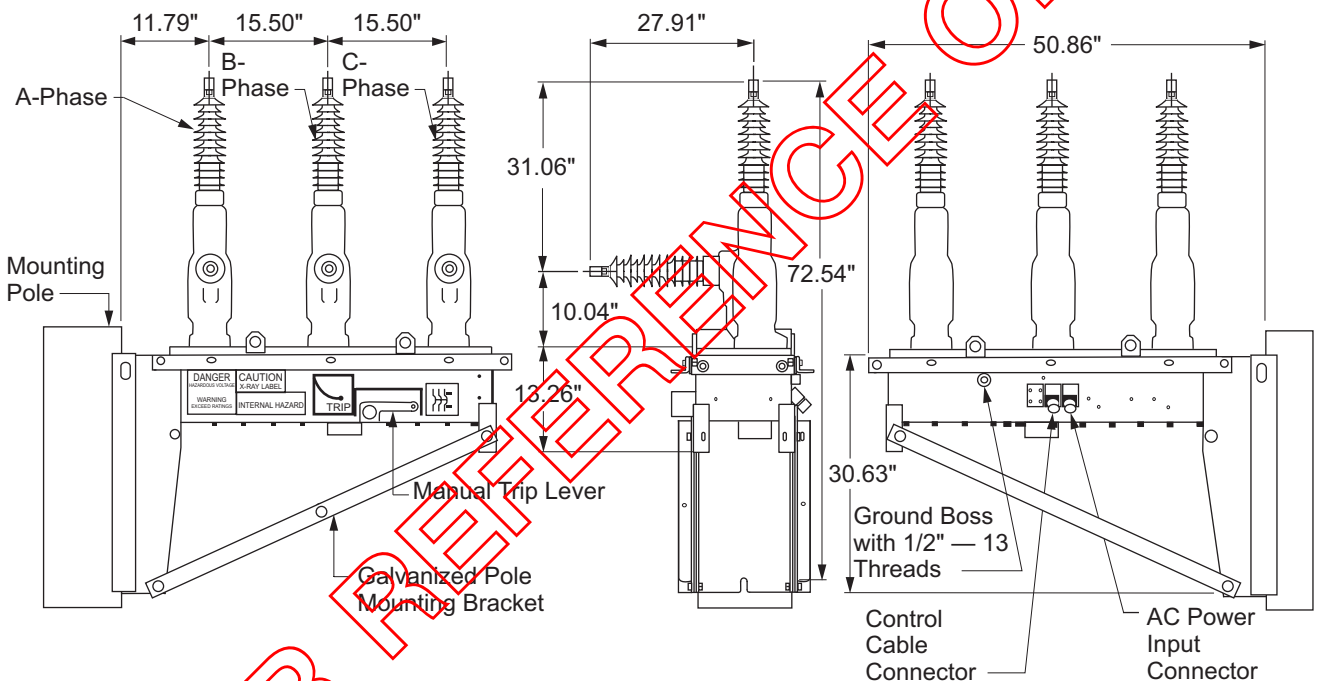

Note(s):

1. G&W Viper 38 kV Electronic AR (SAP 10106595)

Approved by: <i>ajf</i>	Three Phase Overhead Electronic Reclosers (FOR REFERENCE ONLY)	AP 505
Effective Date: 01-25-2019	What's Changed? Standard made "FOR REFERENCE ONLY".	Sheet 37 of 44
		DOH

Scope AP 505.13 Typical McGraw-Edison Type WVE38X 34.5 kV Electronic AR with the CPT Located on the Same Pole

Figure AP 505-32: Typical McGraw-Edison Type WVE38X 34.5 kV Electronic AR with the CPT Located on the Same Pole

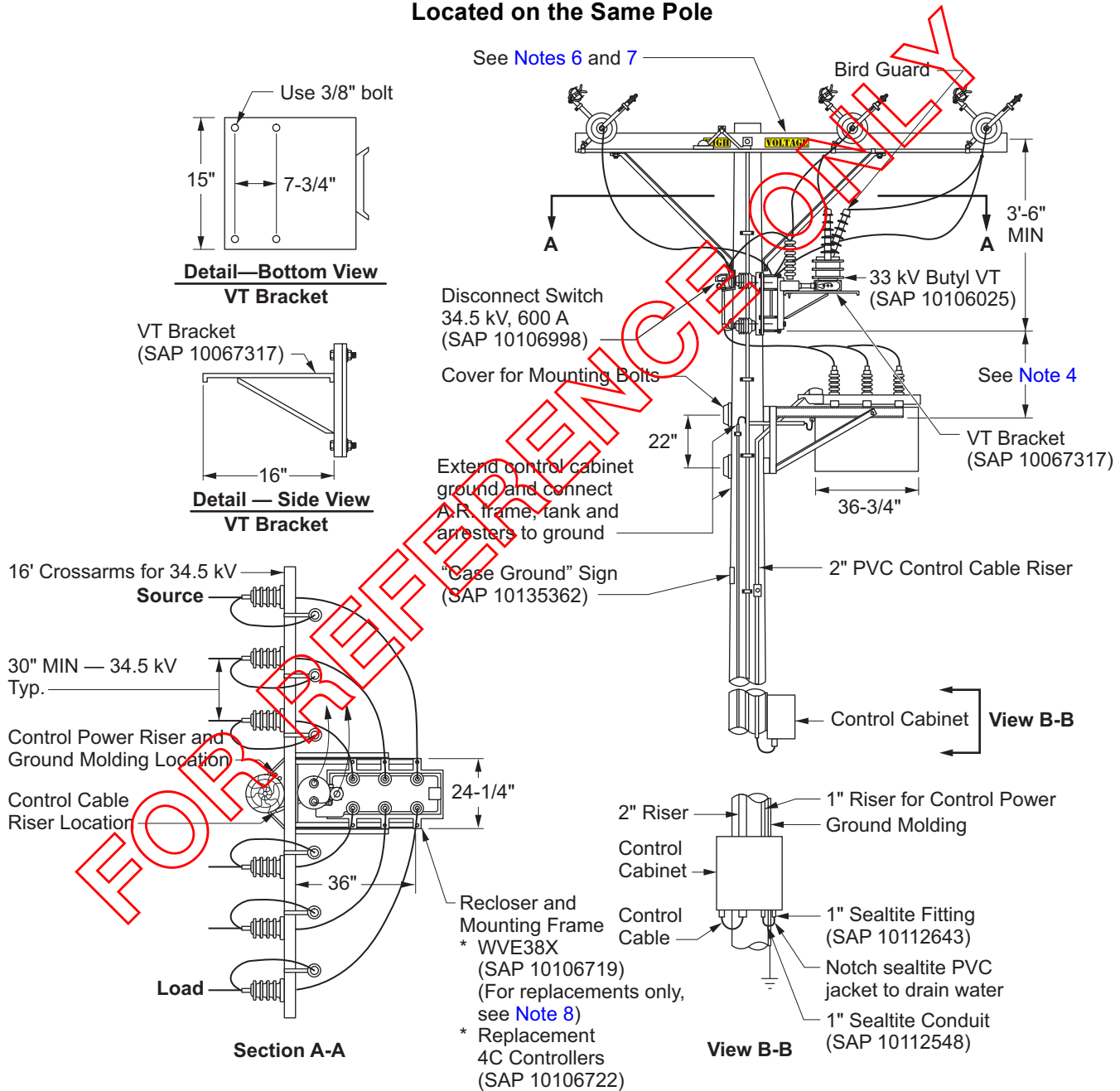

Note(s):

1. The CPT shall serve no load other than the AR and AR controls.
2. CRT for the WVE38X is a 1 kVA Butyl VT non-fused with a 120 V secondary.

AP 505

Three Phase Overhead Electronic Reclosers (FOR REFERENCE ONLY)

Approved by:

a/j

Sheet 38 of 44

What's Changed? Standard made "FOR REFERENCE ONLY".

Effective Date:

DOH

01-25-2019

3. See [Scope AP 505.9](#) for AR, control, and transformer grounding. See [Scope AP 505.10](#) for AR, control, and transformer grounding when the transformer is mounted on an adjacent pole (alternate method). See [GR 105](#) for ground conductor and connection requirements.
4. Set this dimension to maintain a 12-inch minimum between high voltage bushings and leads, and the transformer tank and secondary leads.
5. Install wildlife guards on all bushings and leads.
6. HIGH VOLTAGE signs mounted on crossarms are for existing installations only. For new or replacement HIGH VOLTAGE sign installations, see [PO 120](#).
7. For maintenance purposes, deteriorated HIGH VOLTAGE signs on crossarms shall be removed when work permits. Refer to Distribution Operations and Maintenance Policies and Procedures (DOM), Chapter IM-2.
8. WVE38X (SAP 10106719) shall only be used to replace existing Cooper (McGraw-Edison) ARs. WVE38X is not for new location installations.
9. Per [DC 535](#), Wildlife Protection shall be constructed and installed as applicable for insulators, taps, leads, arresters, cable terminations, and equipment bushings.

FOR REFERENCE ONLY

Approved by: 	Three Phase Overhead Electronic Reclosers (FOR REFERENCE ONLY)	AP 505
Effective Date: 01-25-2019	What's Changed? Standard made "FOR REFERENCE ONLY".	Sheet 39 of 44 <div style="font-size: 24pt; font-weight: bold; margin-top: 5px;">DOH</div>

Scope AP 505.14 Typical AR Connections with the CPT Located on a Separate Pole (Alternate Method)

Figure AP 505-33: Typical Connections for G&W Viper, McGraw-Edison Type WE, NOVA, and WVE38X Electronic ARs with the CPT Located on a Separate Pole (Alternate Method)

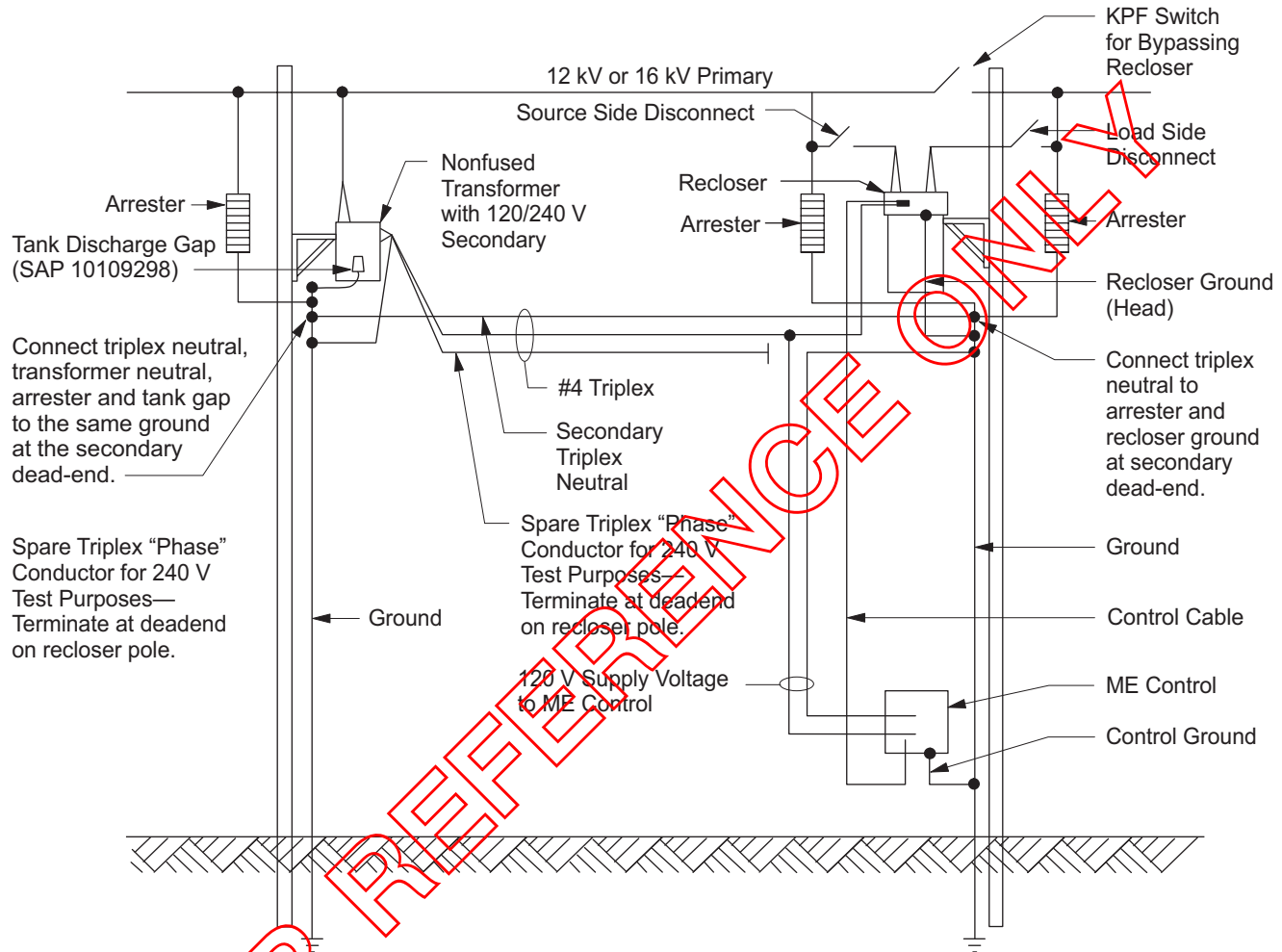

Note(s):

1. Depending on the vintage of the installation the CPT may be a 1 kVA solid dielectric transformer or a 5 kVA conventional transformer with 120/240 V secondary. All CPT installations shall be protected by surge arresters. Conventional oil-filled transformers shall be protected by a tank discharge gap.
2. Control cable shielding shall be grounded to the AR head and to the control cabinet.
3. The CPT shall serve no load other than the AR and AR controls.
4. AR primary bushings are denoted "line" and "load." This is only applicable to ARs with high voltage closing coils. Either side can be used for source or load with WE ARs, NOVA ARs, and Viper ARs.
5. Surge arresters, CPT tank gap, AR tank and frame, and control cabinet grounds shall be connected through the secondary neutral to minimize any potential ground differences between equipment.
6. Per DC 535, Wildlife Protection shall be constructed and installed as applicable for insulators, taps, leads, arresters, cable terminations, and equipment bushings.

AP 505

Three Phase Overhead Electronic Reclosers (FOR REFERENCE ONLY)

Approved by:

a/j

Sheet 40 of 44

What's Changed? Standard made "FOR REFERENCE ONLY".

Effective Date:

DOH

01-25-2019

Scope AP 505.15 Typical Method of Installing a NetComm Radio on a Form 3/3A/4C Controller

Figure AP 505-34: Typical Method of Installing a Netcomm Radio on a Form 3/3A/4C Controller

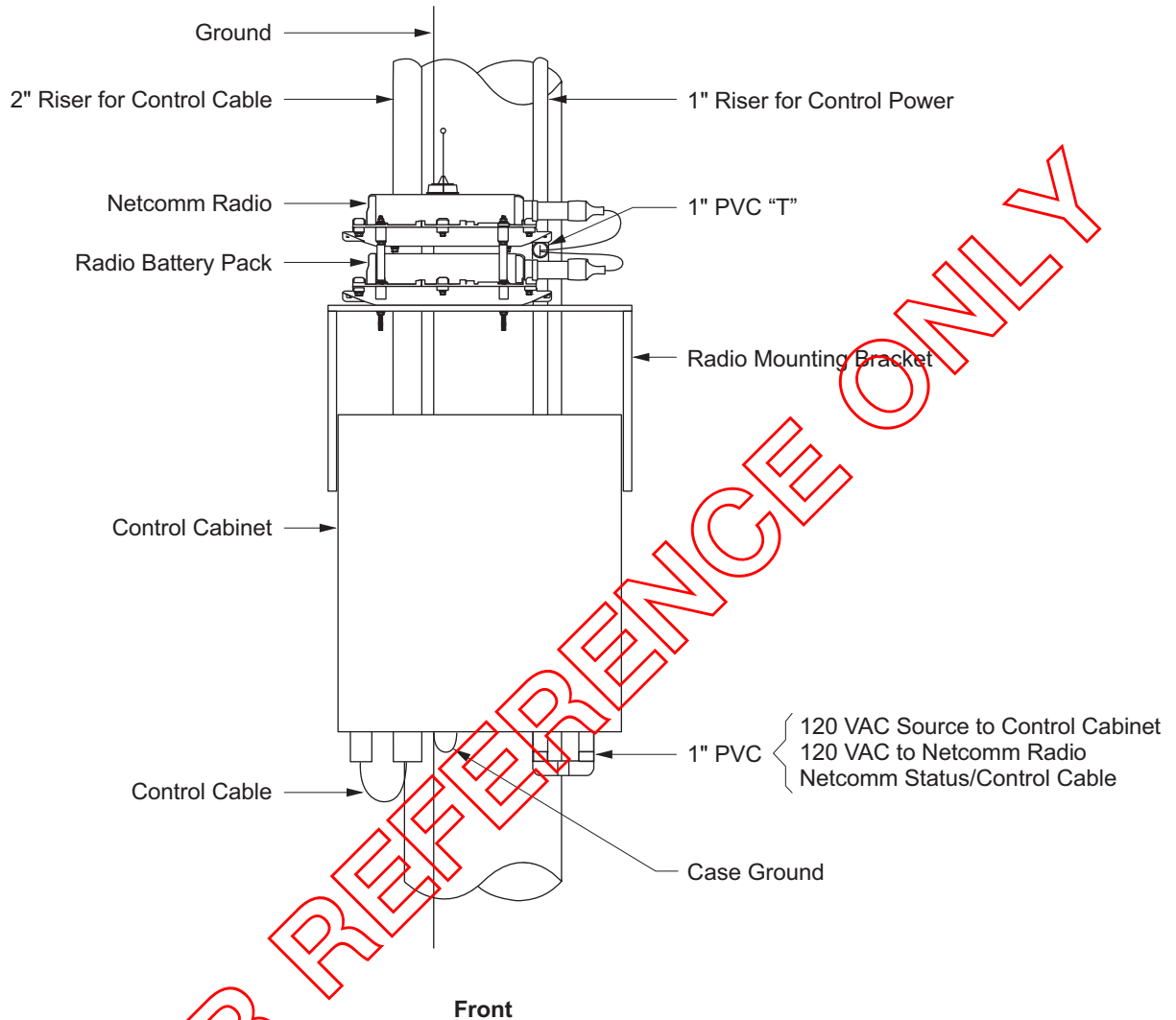

Note(s):

1. When installing a Series 3 (8070) white radio to replace a Series 2 (8050 or 8060) white radio, an interface cable is needed (SAP 10125645).

Approved by: 	Three Phase Overhead Electronic Reclosers (FOR REFERENCE ONLY)	AP 505
Effective Date: 01-25-2019	What's Changed? Standard made "FOR REFERENCE ONLY".	Sheet 41 of 44 DOH

Scope AP 505.16 Wiring Diagram for Addition of Metricom Radio to Cooper Form Electronic 4C AR

Figure AP 505-35: Wiring Diagram for Addition of Metricom Radio to Cooper Form Electronic 4C AR

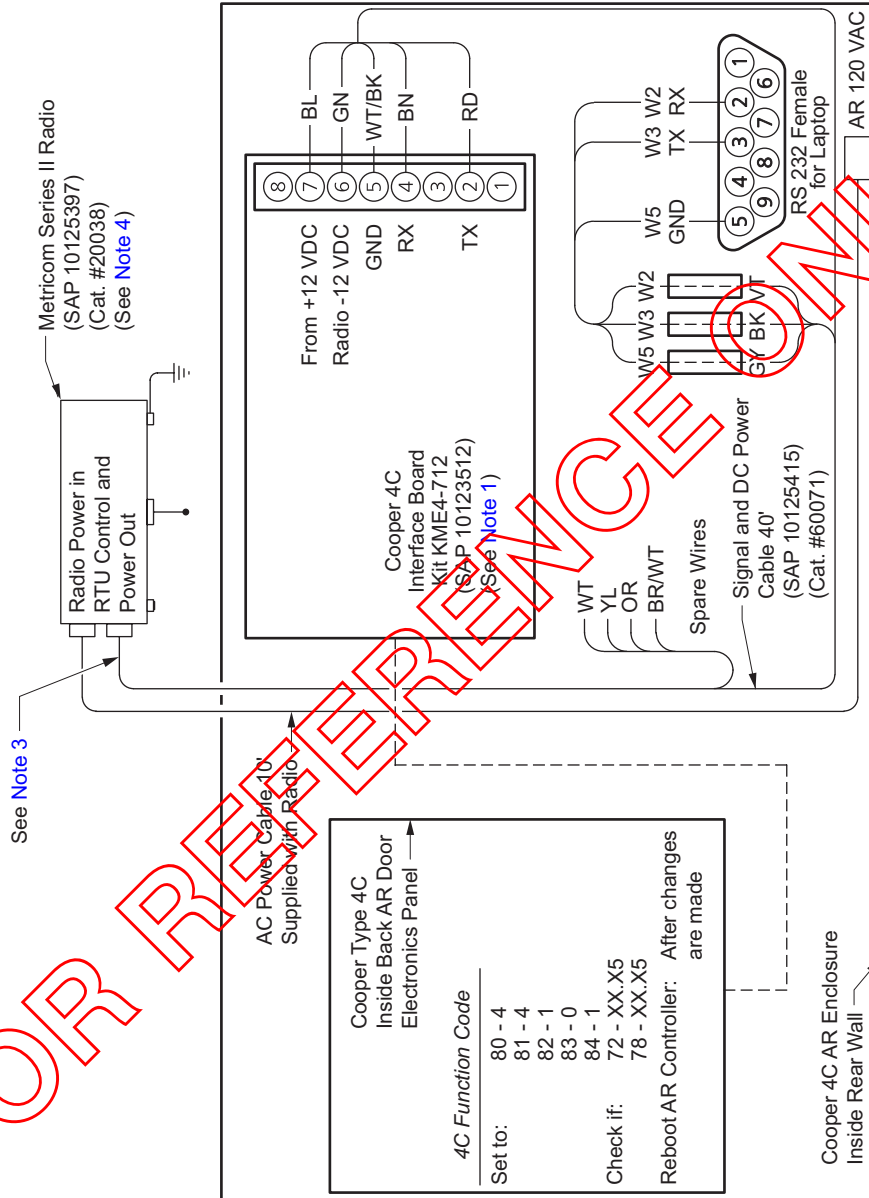

Note(s):

1. Install RS-232 accessory kit per Copper RS-232 Accessory Board Kit KME-712 (SAP 10123512) instructions.
2. Contact Equipment Engineering for any technical questions.
3. When installing a Series 3 (8070) white radio to replace a Series 2 (8050 or 8060) white radio, an interface cable is needed (SAP 10125645). The AC powered backed white radio was used with the initial design of the Form 4C controller.
4. Manufacturer upgrades to Form 4C also allow the use of DC-powered Series II and III radios.

Scope AP 505.17 Wiring Diagram for Automation Conversion of Cooper Form 3/3A Electronic ARs

Figure AP 505-36: Wiring Diagram for Automation Conversion of Cooper Form 3/3A Electronic ARs

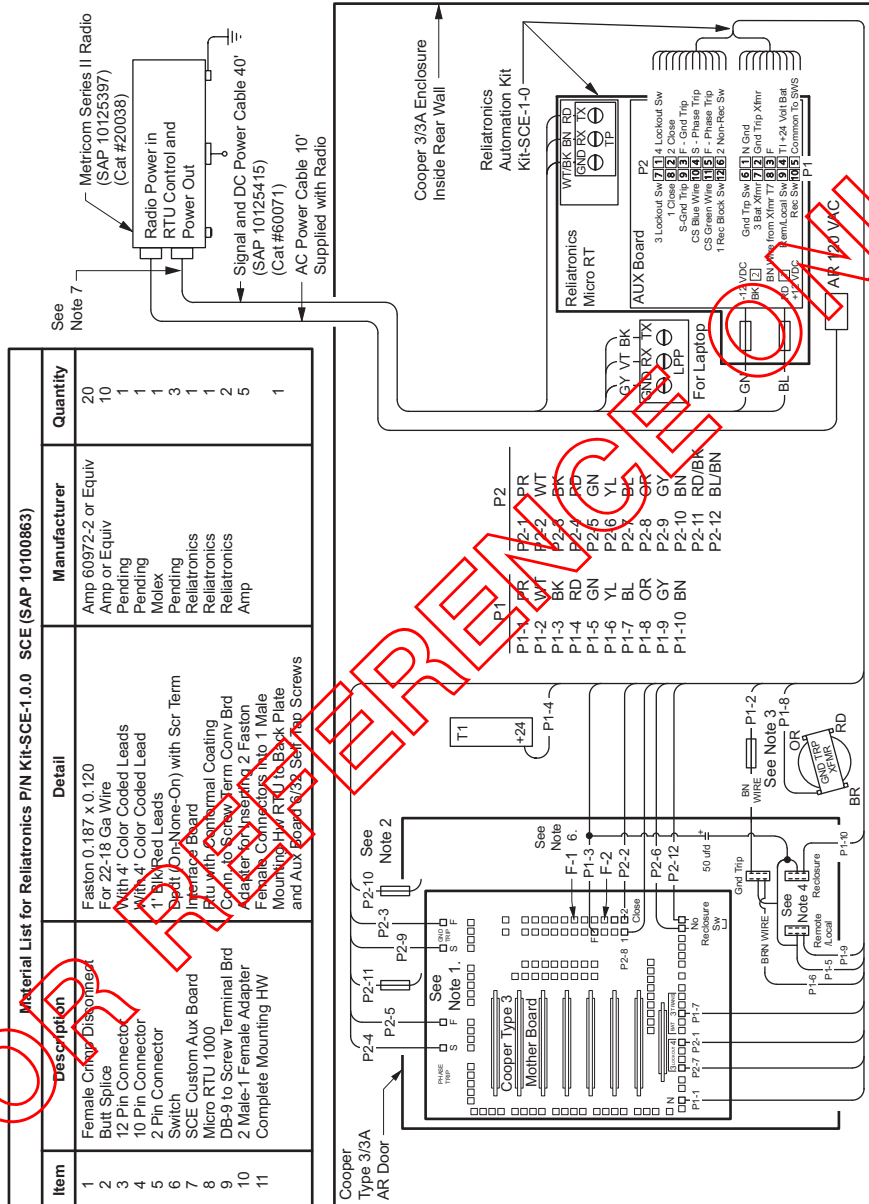

FOR REFERENCE ONLY

Approved by:
ajf
Effective Date:
01-25-2019

Three Phase Overhead Electronic Reclosers (FOR REFERENCE ONLY)

What's Changed? Standard made "FOR REFERENCE ONLY".

AP 505

Sheet 43 of 44

DOH

This page intentionally left blank.

AP 510 Three Phase Overhead Remote Electronic Reclosers with Three Phase Voltage Sensing

Scope AP 510.1 Remote Electronic Recloser Installation Details

1.0 General Information

The G&W Viper-S recloser has a continuous current rating of 630 A and an interrupting rating of 12.5 KA symmetrical. The Viper-S recloser utilizes 120 VAC for control power. The Viper-S recloser is equipped with voltage sensing on six bushings. All recloser installations shall include the installation of a NetComm radio for remote monitoring and control.

The Viper-S recloser is used for both Remote Sectionalizing Recloser (RSR) and Remote Automatic Recloser (RAR) applications.

2.0 Recloser Application, SAP Numbers, and Dimensions

Table AP 510-1: Recloser Details

Circuit Voltage	Integral Voltage Sensor (VS) Ratio	Integral VS Qty.	SAP	Control Configuration	Dimensions
4.16 kV	20:1	6	10209704	14-pin/24 VDC	See Figure 1
12 kV	57.75:1	6	10209474	14-pin/24 VDC	See Figure 1
16 kV	78.583:1	6	10209703	14-pin/24 VDC	See Figure 1
25 kV	120:1	6	10209702	14-pin/24 VDC	See Figure 2
34.5 kV	165.5:1	6	10206225	14-pin/24 VDC	See Figure 2

Approved by: <i>ajf</i>	Three Phase Overhead Remote Electronic Reclosers with Three Phase Voltage Sensing	AP 510
Effective Date: 01-25-2019	What's Changed? Added new details regarding use of the Viper-S for RAR and RSR applications. Added recloser details for 25 and 34.5 kV.	Sheet 1 of 29
		DOH

Figure AP 510-1: G&W Viper-S 27 kV Electronic Recloser

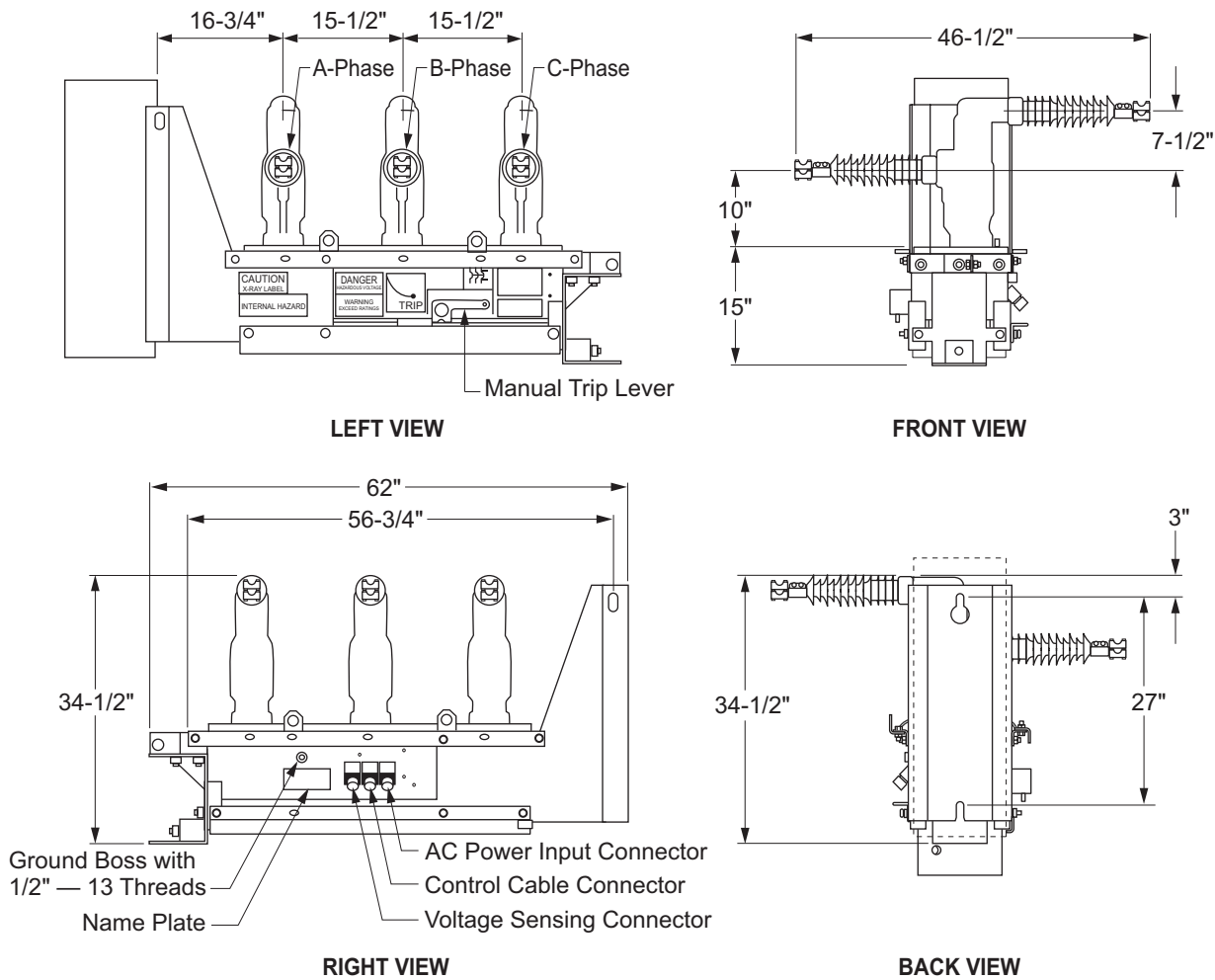

Note(s):

1. The approximate weight of the Remote Electronic Recloser is 500 lb.

Figure AP 510-2: G&W Viper-S 38 kV Electronic Recloser

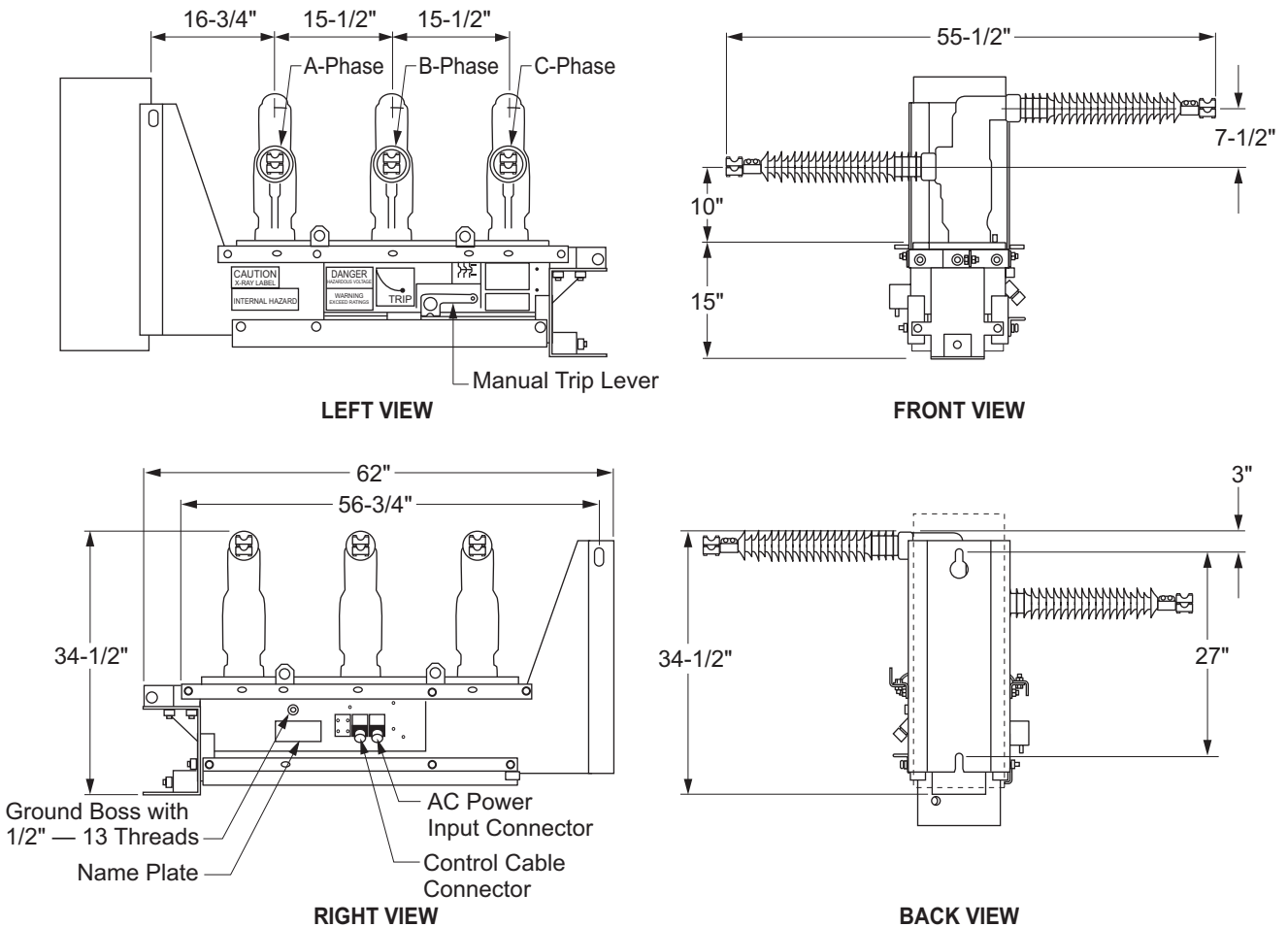

Approved by:

ajj

Three Phase Overhead Remote Electronic Reclosers with Three Phase Voltage Sensing

Effective Date:
01-25-2019

What's Changed? Added new figures for the 38 kV rated recloser.

AP 510

Sheet 3 of 29

DOH

Figure AP 510-3: 4 kV/12 kV/16 kV CPT Mounting Bracket Details

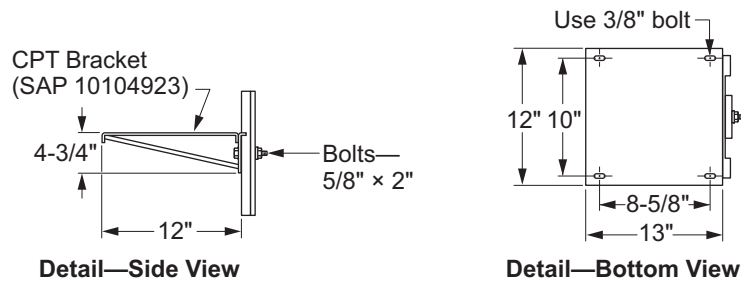

Figure AP 510-4: 25 kV CPT Mounting Bracket Details

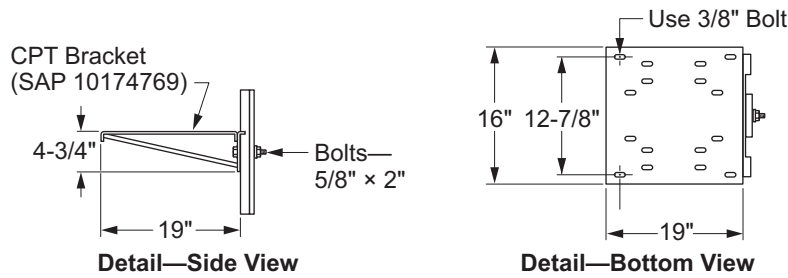
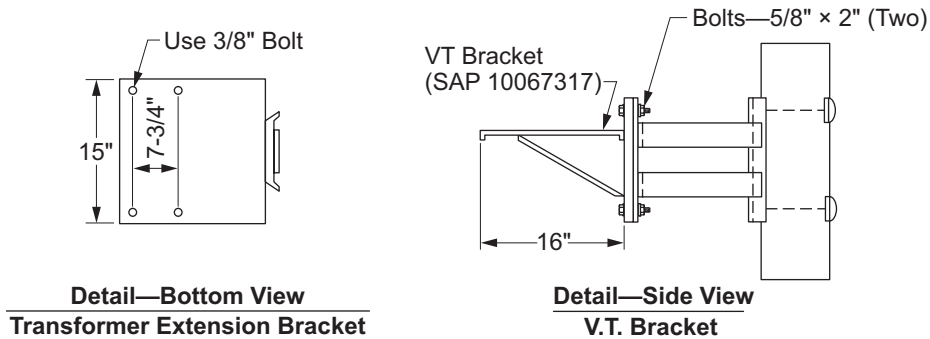

Figure AP 510-5: 33 kV CPT Mounting Bracket Details



3.0 CPT Connections and Grounding Details

Control power transformers shall be mounted to line and load side of the upper disconnect crossarm. For 12 kV and higher, the disconnects and CPT mounting brackets shall be bonded; bonding is optional for 4 kV.

3.1 CPT Riser Installation

Two methods are available for CPT riser installations:

- Option 1: Route individual 1-inch risers from each CPT to controller, resulting in 2 – 1-inch risers down the pole. Conduit and ground wire shall be attached at bottom of upper disconnect crossarm (see [Figure AP 510–6](#)).
- Option 2: Single 1-inch riser on the pole terminating at a “T” junction below the upper disconnect crossarm. One-inch conduit shall be attached to the “T” junction and extend to each CPT (see [Figure AP 510–7](#)).

3.2 CPT Grounding Installation

Two methods are available for CPT secondary neutral grounding:

- Option 1: Ground the secondary neutral at the wire between the CPT secondary termination box and entrance of the 1-inch conduit attached at the bottom of upper disconnect crossarm (see [Figure AP 510–8](#)).
- Option 2: Ground the secondary neutral in the CPT secondary termination box. Connect both a #6 Cu white stranded ground and #12 Cu neutral white insulated wires to the X2 or X3 terminals, based on voltage class. Connect the other end of the #6 stranded white insulated ground lead to the ground (PGW) at the bottom of the upper disconnect crossarm (see [Figure AP 510–9](#)).

Figure AP 510–6: CPT Riser Details for Option 1



Approved by: 	Three Phase Overhead Remote Electronic Reclosers with Three Phase Voltage Sensing	AP 510
Effective Date: 01-25-2019	What's Changed?	Sheet 5 of 29 DOH

Figure AP 510–7: CPT Riser Details for Option 2



Figure AP 510–8: CPT Grounding Details for Option 1



Figure AP 510–9: CPT Grounding Details for Option 2



4.0 Installation Details

Install wildlife guards (SAP 10067783) on all recloser bushings. To provide a location for attaching grounds at the disconnect switch terminals; leave six-inches of uncovered conductor on the leads attached to the lower disconnect terminal (that terminate on the recloser).

Install the wildlife current limiting (CL) fuse cover (SAP 10067793) on CPTs over CLD fusing. Protective ground wire (PGW) (SAP 10109302) may be used for taps for the CPT. Wire covers shall be installed on all bare conductor leads. Use wire cover (SAP 10117061) for #2 AWG bare copper. Use wire cover (SAP 10117062) for 2/0 and 4/0 copper. Refer to [DC 535](#) for other wire sizes and covers.

The CPT (SAP 10105102) has secondary taps for use on either 12 kV or 16 kV applications. The secondary neutral shall be grounded. For 12 kV applications, X3 shall be grounded. For 16 kV applications, X2 shall be grounded. **DO NOT** ground the primary neutral at the recloser installation location.

Surge arresters are required for recloser installations. Arresters shall be installed on the line and load sides of the recloser (refer to [Table AP 410-1](#)) and mounted on the recloser frame (see [Figure AP 510-10](#)).

Figure AP 510-10: Surge Arresters for Recloser Installations



To increase the space for maintenance of the recloser, 12-foot crossarms and the use of the outer insulator pin positions are recommended for primary underbuild applications.

Underbuild circuits shall have a minimum four-foot clearance between the conductors and the bottom of the recloser frame. Communication conductors shall have a minimum four-foot clearance to the bottom of the recloser frame. Refer to [DC 200](#) for clearances between conductors and communication levels.

External Neutral CT taps associated with Sensitive Protections Isolated Neutral 4 kV Systems shall be installed with 2.4 kV insulated cable. Details on ampacity, conduit, and cable sizes for the external CT are included in [Table AP 510-2](#) and [Table AP 510-3](#).

Approved by: 	Three Phase Overhead Remote Electronic Reclosers with Three Phase Voltage Sensing	AP 510
Effective Date: 01-25-2019	What's Changed? Added details for external neutral CT taps taken from DOH AP 505.	Sheet 7 of 29 DOH

Hard drawn copper wire is required for recloser taps for mechanical strength and to prevent interactions with the recloser copper alloy terminals. The recloser tap requirements are detailed in [Table AP 510–2](#). The standard recloser terminals will accept copper conductor range between #2–500MCM. For larger wire sizes NEMA style terminals can be attached to the recloser terminals, (refer to DOM SW-1 for details on replacement parts). Use two T-bolt connectors (2/0 AWG — 350 kcmil SAP 10110830; #6 AWG — 2/0 AWG SAP 1011829) per terminal pad to make connections at disconnect switches.

Table AP 510–2: Recloser Tap Requirement Chart

Item	Recloser Conductor Requirements	Aluminum Span Conductor			Copper Span Conductor	
		#4 through #2 ACSR	1/0 through 4/0 ACSR	336.4 ACSR	#4 through 2/0 Cu	4/0 Cu
1	Leads between the span conductors and disconnect switches	#2 Cu Hard Drawn SAP 10109330	2/0 Cu Hard Drawn SAP 10109331	4/0 Cu Hard Drawn SAP 10109332	2/0 Cu Hard Drawn SAP 10109331	4/0 Cu Hard Drawn SAP 10109332
2	Leads between the disconnect switches and the recloser terminals	2/0 Cu Hard Drawn SAP 10109331	4/0 Cu Hard Drawn SAP 10109332	4/0 Cu Hard Drawn SAP 10109332	4/0 Cu Hard Drawn SAP 10109332	4/0 Cu Hard Drawn SAP 10109332
3	Recommended leads between the Neutral disconnect and the Neutral CT terminals ^{a/} (4 kV isolated neutral only)	2 Runs #6 Insulated Cu Cable SAP 10110173	1 Run 4/0 Insulated Cu Cable SAP 10110187	1 Run 350 kcmil Insulated Cu Cable SAP 10110188	1 Run 4/0 Insulated Cu Cable SAP 10110187	1 Run 350 kcmil Insulated Cu Cable SAP 10110188
4	Maximum Loading (amps) ^{b/ c/}	160-210	280-415	540	195-405	540

^{a/} The Recommended CT wiring is based on the largest wire ampacity for the range of the chart. The Neutral conductor capacity is recommended to be 75 percent of the phase conductors, with a minimum capacity of 50 percent. Refer to [Table AP 505–3](#) for alternative conductor options.

^{b/} Loading can be limited by the recloser ratings, tap sizes, and span wire sizes. The values in the chart assume a recloser continuous rating of 630 A, the range is based on the available range of the span conductors.

^{c/} In some situations the recloser minimum trip settings may be required to be higher than the ampacity of the line section to allow for proper coordination.

Table AP 510–3: 2.4 kV Insulated Cable Ampacities and Conduit Recommendations for the AR Neutral CT Conductor

SAP	Size (AWG/kcmil)	Ampacity ^{a/}	MIN Conduit for 1 Run ^{b/}	MIN Conduit for 2 Runs ^{b/}	MIN Conduit for 3 Runs ^{b/}
10110173	#6	75	1-inch	2-inch	2-inch
10110174	#4	97	1-inch	2-inch	2-inch
10110175	#2	130	1.5-inch	2-inch	2.5-inch
10110187	4/0	280	1.5-inch	3-inch	3-inch
10110188	350	385	2-inch	4-inch	4-inch
10110189	500	475	2-inch	4-inch	4-inch

^{a/} The ampacity can be doubled or tripled with installation of multiple conductor runs.

^{b/} Two-hole stackable lugs may be installed for up to four runs of cable for the CT and disconnect switches. It is best practice to limit the parallel runs to two cables to avoid stacking connectors on both sides of the terminal pads.

AP 510 Sheet 8 of 29 DOH	Three Phase Overhead Remote Electronic Reclosers with Three Phase Voltage Sensing	Approved by: <i>ajf</i>
	What's Changed? Added details for external neutral sensing CT taken from DOH AP 505. Added new table for neutral cable ampacities.	Effective Date: 01-25-2019

5.0 Remote Electronic Recloser prior to Commissioning after Construction

After the installation of the recloser, the equipment needs to be commissioned by Distribution Apparatus Test. Contact the Automation hotline when construction is complete; additionally, notify Apparatus Test of the work completed whenever possible. The construction crew shall configure the equipment for Distribution Apparatus Test as follows:

- Line and Load disconnects connected to both the source and the recloser
- Line and Load disconnects in the OPEN position
- Recloser breaker in the OPEN position
- By-pass switch in CLOSED position, unless otherwise indicated on the Work Order, such as for a circuit line
- CPTs tapped to the primary circuit
 - Battery disconnected
 - 120 VAC fuseholders open with secondaries connected
 - If circuits are energized, check for 120 V at the open fuseholders.
- Release to substation jurisdiction that recloser has been installed and is NOT READY FOR SERVICE, Follow the procedure stated in System Operating Bulletin #25.

Figure AP 510–11: 120 V Control Power Connections



Line-side CPT secondary wiring color should be black (Hot, SAP 10109776) and black with white tracer (Neutral, SAP 10109783). Load-side CPT secondary wiring should be red (Hot, SAP 10109775) and red with white tracer (Neutral, SAP 10109780).

Approved by: 	Three Phase Overhead Remote Electronic Reclosers with Three Phase Voltage Sensing	AP 510
Effective Date: 01-25-2019	What's Changed?	Sheet 9 of 29 DOH

6.0 Controller Mounting Height Requirements from Grade to Lowest Control Cable

The preferred mounting height for the RSR is eight feet. The preferred mounting height for the RAR is five feet for operations and maintenance only when the mounting height conditions are satisfied. When the site conditions do not allow for the preferred mounting range the controller shall be mounted at 8 feet or higher. See [Table AP 510–4](#) for recloser mounting height requirements.

Table AP 510–4: Recloser Controller Mounting Height Requirements

Preferred	5' above ground for RAR installations; 8' above ground for RSR installations
Higher than 8 feet	<p>At a specified height, as determined by the planner, after contacting the responsible Apparatus Foreman due to the following conditions:</p> <ul style="list-style-type: none"> • Ability to work over fence with bucket truck • Bus Stop • Communications obstacles • Fences and walls • Parking area • Slopes • Traffic — vehicle and pedestrian • Trees and shrubs <p>Examples:</p> <ul style="list-style-type: none"> • 6' below communication cable (usually 12'–15' above ground) • 4' below communication cable with no junction box (usually 14'–17' above ground) • 13'-6" above ground level to clear truck traffic <p>Note: Contact the responsible Apparatus Foreman if the control is planned to be mounted above 10'.</p>
Lower (4–8 feet)	<p>In SCE Substation and locked fence areas.</p> <p>OR</p> <p>All the following conditions shall be met (Usually in Rural Areas):</p> <ul style="list-style-type: none"> • Away from obstacles — fences and walls • Away from parking area • Away from traffic signals • Away from traffic — vehicle and pedestrian

AP 510

Three Phase Overhead Remote Electronic Reclosers with Three Phase Voltage Sensing

Approved by:



Sheet 10 of 29

What's Changed? Added details for mounting height criteria for control cabinet for RAR and RSR applications.

Effective Date:

01-25-2019

DOH

Scope AP 510.2 G&W Viper-S Remote Electronic Reclosers with Three Phase Voltage Sensing for 4 kV Installations

Figure AP 510-12: Typical G&W Viper-S Recloser for 4 kV with the CPT Located on the Same Pole

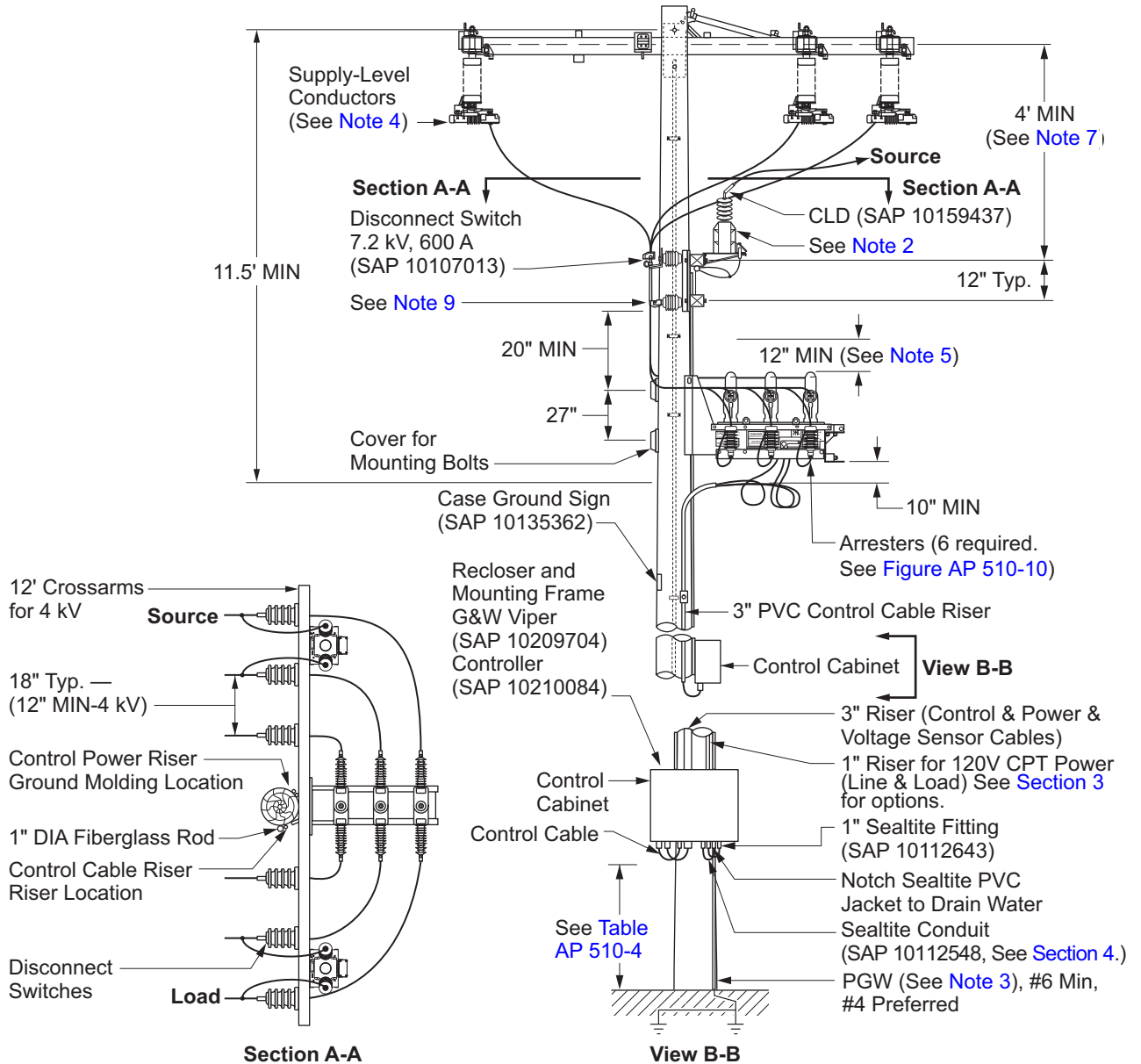

Note(s):

1. The CPT shall serve no load other than the recloser and recloser controls.
2. Control Power Transformer (CPT) Material Number — 2400 V/120 V CPT (SAP 10177910); 4160 V/120 V CPT (SAP 10177919); 4800 V/120 V (SAP 10177922).

Approved by:

ajf

Three Phase Overhead Remote Electronic Reclosers with Three Phase Voltage Sensing

AP 510

Effective Date:
01-25-2019

What's Changed? Updated notes and references from "RSR" to general "recloser".

Sheet 11 of 29

DOH

3. See [Scope AP 510.7](#) for recloser, control, and CPT grounding. Refer to [GR 105](#) for ground conductor and connection requirements.
4. Refer to [AP 336](#) for installation requirements for Omni-Rupter bypass switch, the supply conductors shall be dead-ended to the switch crossarm.
5. Maintain 12-inch minimum separation between high voltage bushings, and the transformer tank, and all secondary leads.
6. Refer to [AP 410](#) and [GR 107](#) for surge arrester installation requirements.
7. Maintain 18-inch minimum (radial) separation between CPT or arrester leads/bushings and the switch blades.
8. To provide a location for grounding at the disconnect switch terminals; leave 6-inches of uncovered conductor on the leads attached to the lower disconnect terminal (that terminate on the recloser).
9. Per [DC 535](#), Wildlife Protection shall be constructed and installed as applicable for insulators, taps, leads, arresters, cable terminations, and equipment bushings.
10. Use two T-Bolt connectors (2/0 AWG — 350 kcmil SAP 10110830; #6 AWG — 2/0 AWG SAP 10110829) per terminal pad to make connections at disconnect switches.

AP 510	Three Phase Overhead Remote Electronic Reclosers with Three Phase Voltage Sensing	Approved by: <i>a/j</i>
Sheet 12 of 29	What's Changed? Updated notes and references from "RSR" to general "recloser".	Effective Date:
DOH		01-25-2019

Figure AP 510-13: Typical G&W Viper-S Recloser for 4 kV with the CPT Located on the Same Pole (Alternate Method Using Hughes Adapter)

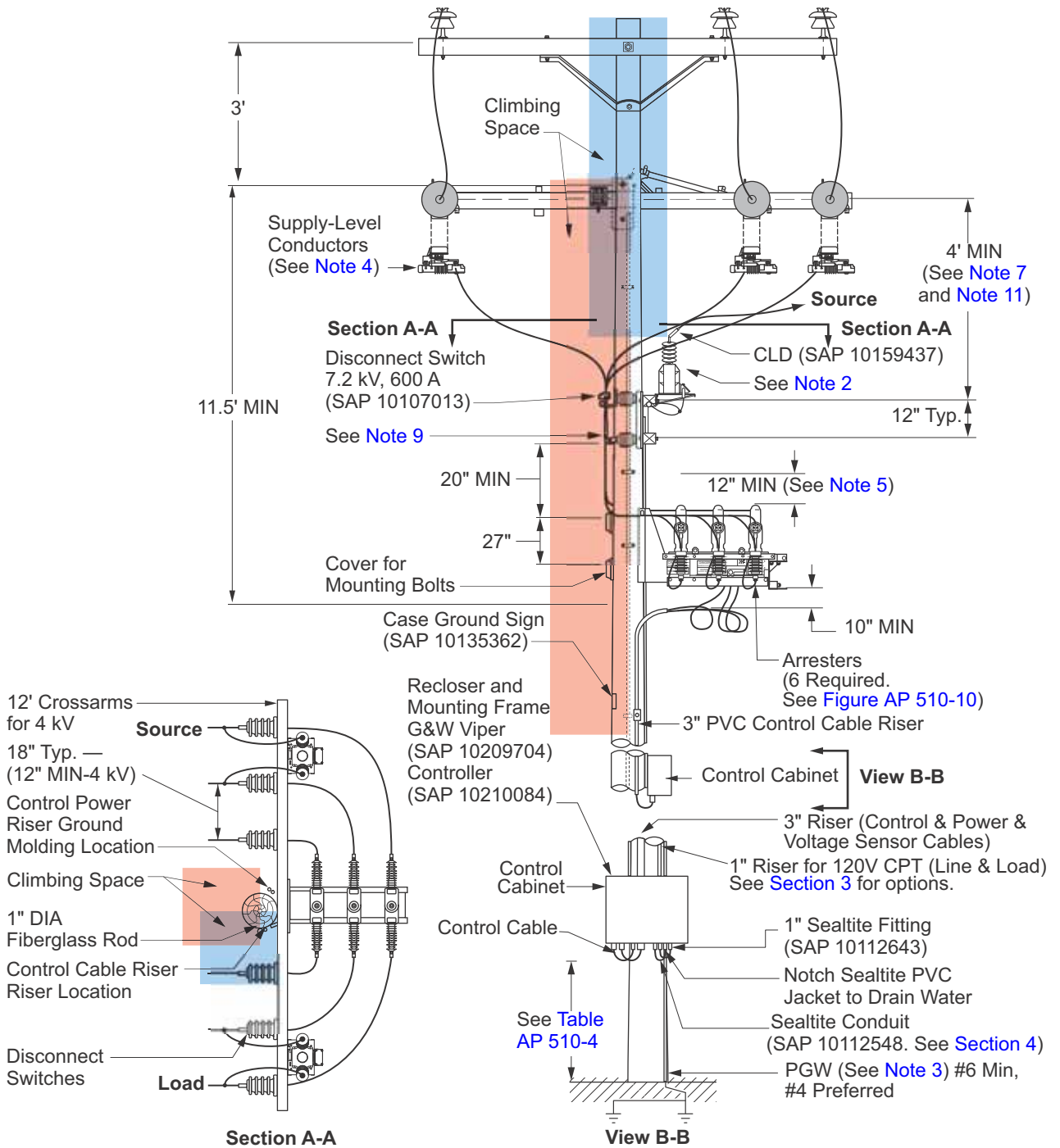

Approved by:

ajf

Three Phase Overhead Remote Electronic Reclosers with Three Phase Voltage Sensing

Effective Date:
01-25-2019

What's Changed? Updated notes and references from "RSR" to general "recloser".

AP 510

Sheet 13 of 29

DOH

Note(s):

1. The CPT shall serve no load other than the recloser and recloser controls.
2. Control Power Transformer (CPT) Material Number — 2400 V/120 V CPT (SAP 10177910); 4160 V/120 V CPT (SAP 10177919); 4800 V/120 V (SAP 10177922).
3. See [Scope AP 510.7](#) for recloser, control, and CPT grounding. Refer to [GR 105](#) for ground conductor and connection requirements.
4. Refer to [AP 336](#) for installation requirements for Omni-Rupter bypass switch.
5. Maintain 12-inch minimum separation between high voltage bushings, and the transformer tank, and all secondary leads.
6. Refer to [AP 410](#) and [GR 107](#) for surge arrester installation requirements.
7. Maintain 18-inch minimum (radial) separation between CPT or arrester leads/bushings and the switch blades.
8. To provide a location for grounding at the disconnect switch terminals; leave 6-inches of uncovered conductor on the leads attached to the lower disconnect terminal (that terminate on the recloser).
9. Per [DC 535](#), Wildlife Protection shall be constructed and installed as applicable for insulators, taps, leads, arresters, cable terminations, and equipment bushings.
10. Use two T-Bolt connectors (2/0 AWG — 350 kcmil SAP 10110830; #6 AWG — 2/0 AWG SAP 10110829) per terminal pad to make connections at disconnect switches.
11. Taps from the Hughes adapters to disconnect switches shall be formed so as not to obstruct the required climbing space. When possible, the inside (closest to the pole) and middle disconnects should be tapped to the Omni-Rupter phases furthest from the climbing space.
12. Climbing Space required — 30" × 30".

AP 510	Three Phase Overhead Remote Electronic Reclosers with Three Phase Voltage Sensing	Approved by: <i>ajf</i>
Sheet 14 of 29	What's Changed? Updated notes and references from "RSR" to general "recloser".	Effective Date:
DOH		01-25-2019

Scope AP 510.3 G&W Viper-S Recloser for 4 kV Installations with Neutral Sensing CT

Figure AP 510-14: Typical G&W Viper-S Electronic Reclosers for 4 kV with Neutral Sensing CT

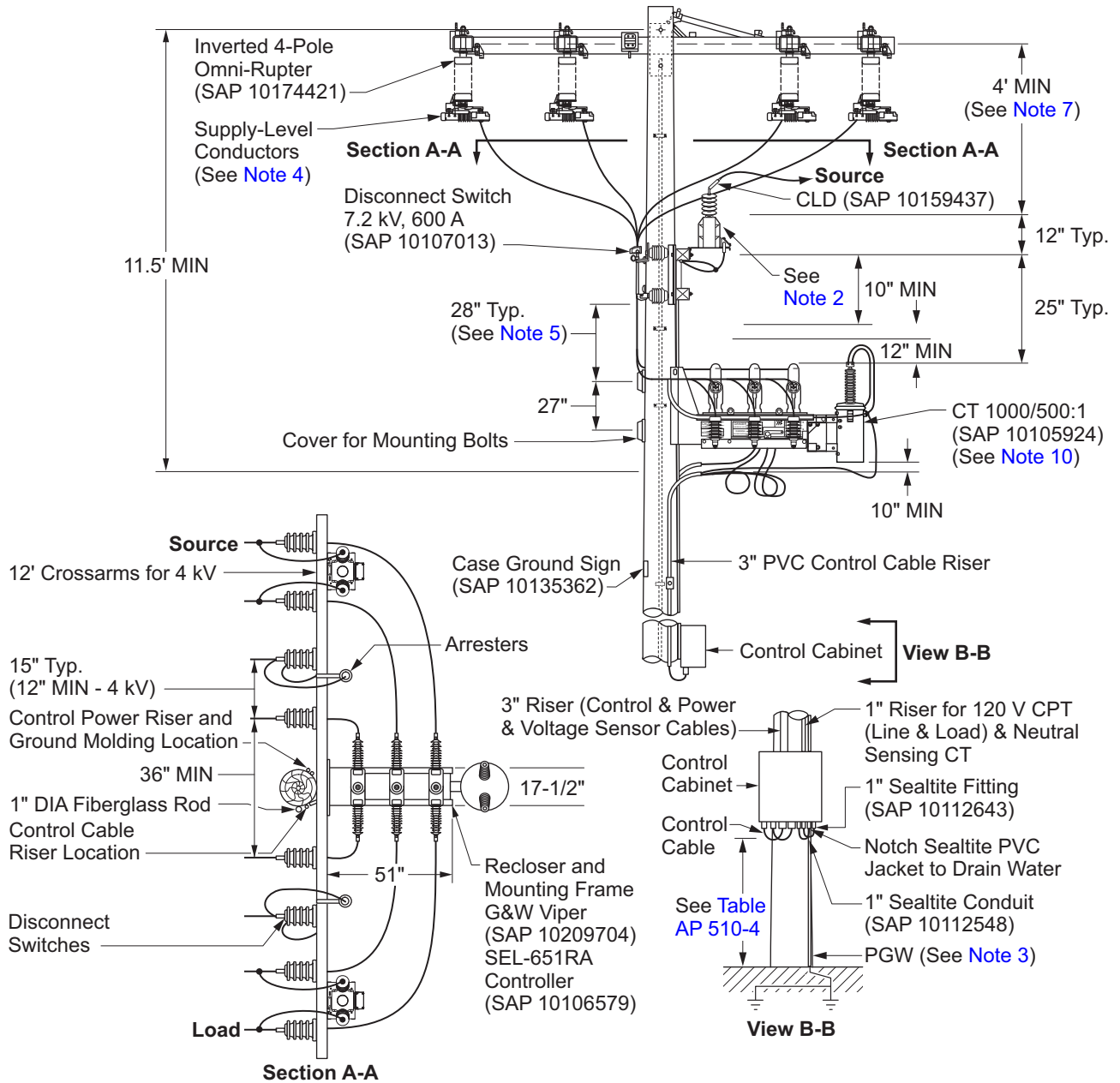

Note(s):

1. The CPT shall serve no load other than the AR and AR controls.
2. Control Power Transformer (CPT) Material Number-2400 V/120 V CPT (SAP 10177910); 4160 V/120 V CPT (SAP 10177919); 4800 V/120 V (SAP 10177922). Mount the CPT Bracket (SAP 10104923) using the lower cross-arm through-bolt. Install covers on the bolt heads. Do not ground CPT mounting bracket.

Approved by:

ajj

Three Phase Overhead Remote Electronic Reclosers with Three Phase Voltage Sensing

AP 510

Effective Date:
01-25-2019

What's Changed? New Figure and notes for Viper-S Recloser for 4 kV Installations with neutral sensing CT.

Sheet 15 of 29

DOH

3. Refer to [Scope AP 510.7](#) for recloser, control, and CPT grounding. Refer to [GR 105](#) for ground conductor and connection requirements. The external CT secondary shall be grounded.
4. Refer to [AP 336](#) for installation requirements for Omni-Rupter bypass switch, the supply conductors shall be dead-ended to the switch crossarm.
5. Maintain 12-inch minimum separation between high voltage bushings, the transformer tank, and all secondary leads.
6. Refer to [AP 410](#) and [GR 107](#) for surge arrester installation requirements.
7. Maintain 18-inch minimum (radial) separation between CPT or arrester leads/bushings and the switch blades.
8. To provide a location for grounding at the disconnect switch terminals; leave six-inches of uncovered conductor on the leads that terminate on the recloser.
9. Per [DC 535](#), Wildlife Protection shall be constructed and installed as applicable for insulators, taps, leads, arresters, cable terminations, and equipment bushings.
10. CT primary leads shall be 2.4 kV insulated cable installed in conduit per requirements established in [Scope AP 510.1, Section 4.0](#)). The CT is provided with a secondary cable (30-ft 3C-#16 AWG) with water tight connector that terminates to the CT. The CT secondary cable is installed in the control power riser. CT secondary leads shall be terminated to a shorting test switch in the recloser control enclosure.

AP 510	Three Phase Overhead Remote Electronic Reclosers with Three Phase Voltage Sensing	Approved by: <i>a/j</i>
Sheet 16 of 29	What's Changed? New Figure and notes for Viper-S Recloser for 4 kV Installations with neutral sensing CT.	Effective Date:
DOH		01-25-2019

Figure AP 510-15: Typical G&W Viper-S Electronic Reclosers for 4 kV with Neutral Sensing CT (Alternate Method Using Hughes Adapter)

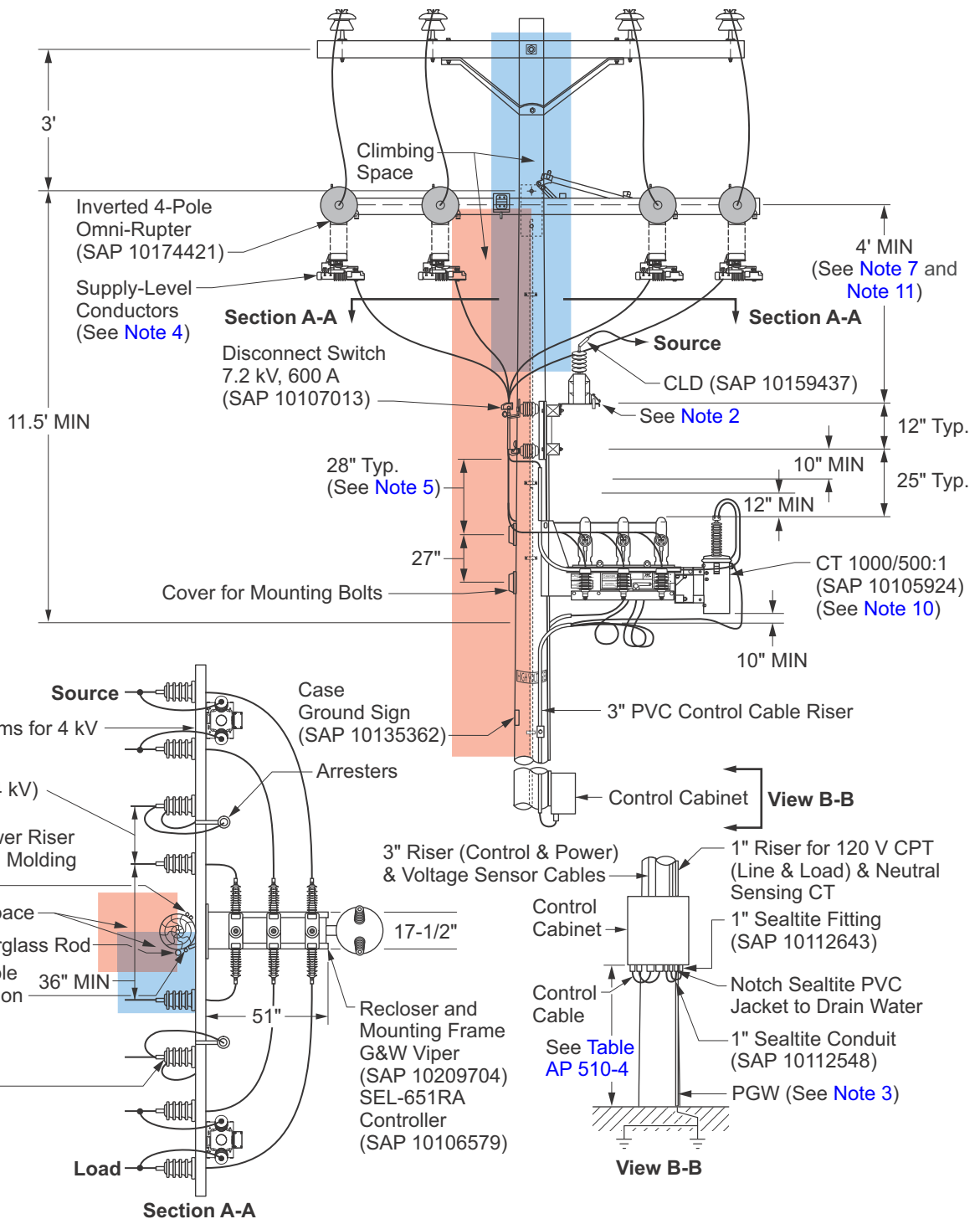

Approved by:
ajj

Three Phase Overhead Remote Electronic Reclosers with Three Phase Voltage Sensing

AP 510

Effective Date:
01-25-2019

What's Changed? New Figure and notes for below the arm Viper-S Recloser for 4 kV Installations with neutral sensing CT.

Sheet 17 of 29

DOH

Note(s):

1. The CPT shall serve no load other than the recloser and recloser controls.
2. Control Power Transformer (CPT) Material Number-2400 V/120 V CPT (SAP 10177910); 4160 V/120 V CPT (SAP 10177919); 4800 V/120 V (SAP 10177922). Mount the CPT Bracket (SAP 10104923) using the lower cross-arm through-bolt. Install covers on the bolt heads. Do not ground CPT mounting bracket.
3. Refer to [Scope AP 510.7](#) for recloser, control, and CPT grounding. Refer to [GR 105](#) for ground conductor and connection requirements. The external CT secondary shall be grounded.
4. Refer to [AP 336](#) for installation requirements for Omni-Rupter bypass switch.
5. Maintain 12-inch minimum separation between high voltage bushings, the transformer tank, and all secondary leads.
6. Refer to [AP 410](#) and [GR 107](#) for surge arrester installation requirements.
7. Maintain 18-inch minimum (radial) separation between CPT or arrester leads/bushings and the switch blades.
8. To provide a location for grounding at the disconnect switch terminals; leave six-inches of uncovered conductor on the leads that terminate on the recloser.
9. Per [DC 535](#), Wildlife Protection shall be constructed and installed as applicable for insulators, taps, leads, arresters, cable terminations, and equipment bushings.
10. CT primary leads shall be 2.4 kV insulated cable installed in conduit per requirements established in Scope AP 505.1, [Section 4.0](#). The CT is provided with a secondary cable (30-ft 3C-#16 AWG) with water tight connector that terminates to the CT. The CT secondary cable is installed in the control power riser. CT secondary leads shall be terminated to a shorting test switch in the AR control enclosure.
11. Taps from the Hughes adapters to disconnect switches shall be formed so as not to obstruct the required climbing space. When possible, the inside (closest to the pole) and middle disconnects should be tapped to the Omni-Rupter phases furthest from the climbing space.
12. Climbing Space required — 30" × 30".

AP 510	Three Phase Overhead Remote Electronic Reclosers with Three Phase Voltage Sensing	Approved by: <i>ajf</i>
Sheet 18 of 29	What's Changed? New Figure and notes for below the arm Viper-S Recloser for 4 kV Installations with neutral sensing CT.	Effective Date:
DOH		01-25-2019

Figure AP 510-16: CT Equipment Dimensions

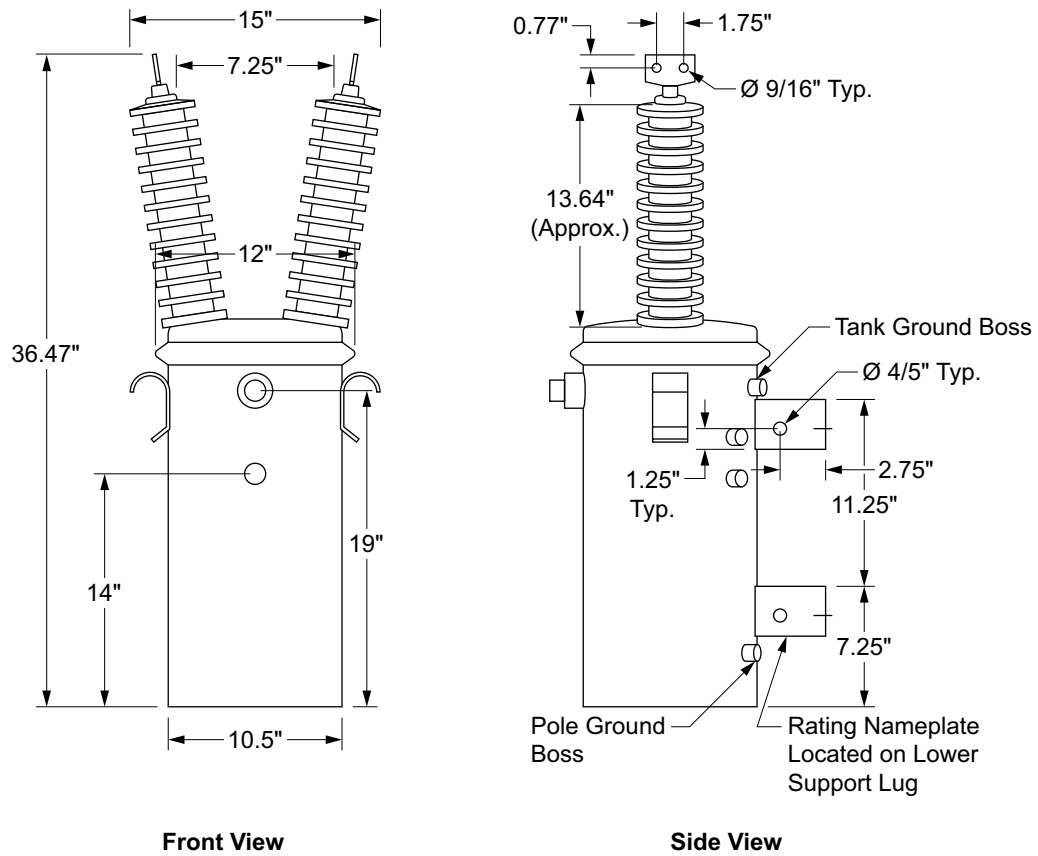

Note(s):

1. Approximate weight of CT is 125 lb.

Approved by:

ajf

Three Phase Overhead Remote Electronic Reclosers with Three Phase Voltage Sensing

AP 510

Effective Date:
01-25-2019

What's Changed? Added new figure for CT equipment dimensions.

Sheet 19 of 29

DOH

Figure AP 510-17: CT Secondary Connection Details

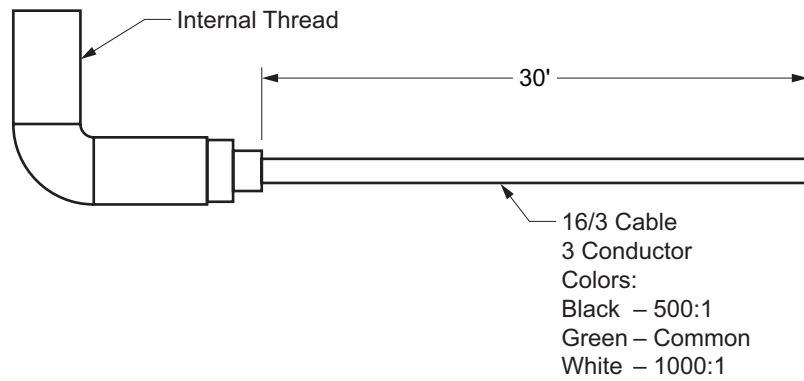
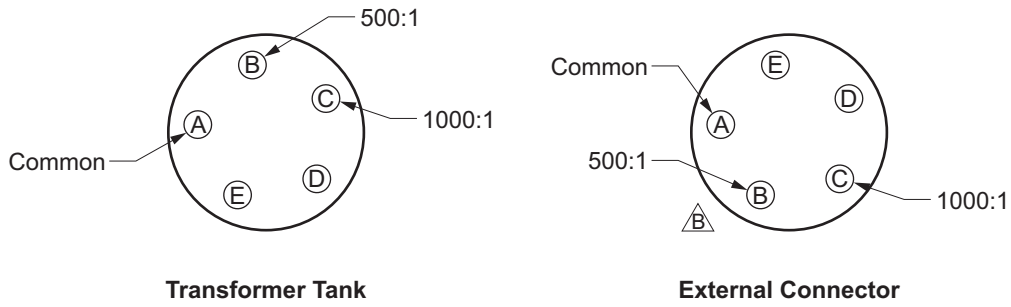

CT Secondary Cable

Scope AP 510.4 G&W Viper-S Remote Electronic Reclosers with Three Phase Voltage Sensing for 12/16 kV Installations

Figure AP 510-18: Typical G&W Viper-S Recloser for 12/16 kV with the CPT Located on the Same Pole

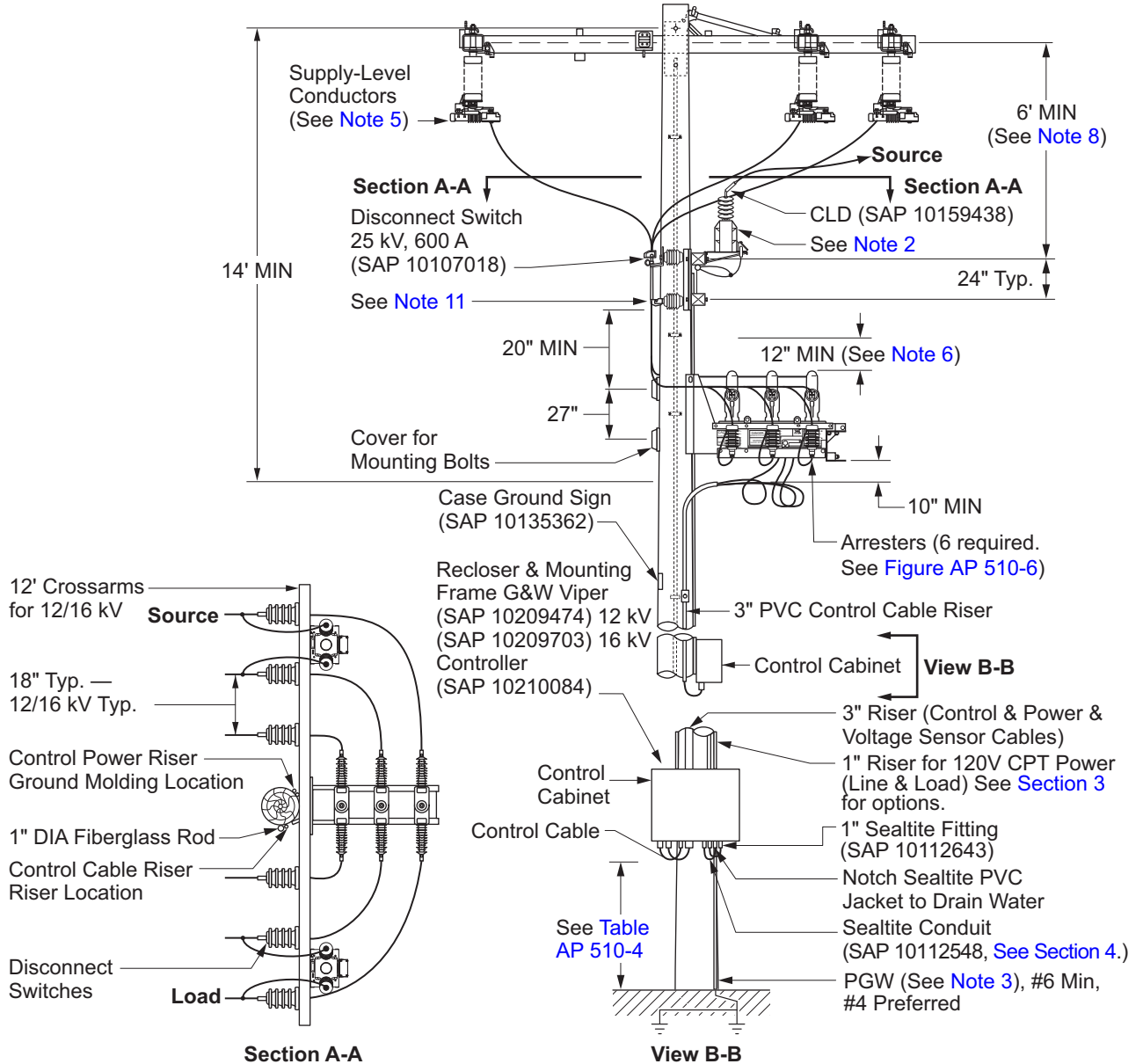

Note(s):

1. The CPT shall serve no load other than the recloser and recloser controls.
2. CPT to be rated 980 VA solid dielectric with 120 V fused secondary. CPT (SAP 10105102); CPT bracket (SAP 10104923). Do not ground the CPT bracket.
3. See [Scope AP 510.7](#) for recloser, control, and CPT grounding. Refer to [GR 105](#) for ground conductor and connection requirements.

Approved by:

ajj

Three Phase Overhead Remote Electronic Reclosers with Three Phase Voltage Sensing

AP 510

Effective Date:
01-25-2019

What's Changed? Updated notes and references from "RSR" to general "recloser".

Sheet 21 of 29

DOH

4. Install wildlife guards on all bushings and leads.
5. Refer to [AP 336](#) for installation requirements for Omni-Rupter bypass switch, the supply conductors shall be dead-ended to the switch crossarm.
6. Maintain 12-inch minimum separation between high voltage bushings and the CPT mounting bracket, and all secondary leads.
7. Refer to [AP 410](#) and [GR 107](#) for surge arrester installation requirements.
8. Maintain 18-inch minimum (radial) separation between CPT or arrester leads/bushings and the switch blades.
9. To provide a location for grounding at the disconnect switch terminals; leave 6-inches of uncovered conductor on the leads attached to the lower disconnect terminal (that terminate on the recloser).
10. Per [DC 535](#), Wildlife Protection shall be constructed and installed as applicable for insulators, taps, leads, arresters, cable terminations, and equipment bushings.
11. Use two T-Bolt connectors (2/0 AWG — 350 kcmil SAP 10110830; #6 AWG — 2/0 AWG SAP 10110829) per terminal pad to make connections at disconnect switches.
12. Refer to [PO 120](#) for High Voltage sign installation requirements.

AP 510	Three Phase Overhead Remote Electronic Reclosers with Three Phase Voltage Sensing	Approved by: <i>a/j</i>
Sheet 22 of 29	What's Changed?	Effective Date:
DOH		01-25-2019

Figure AP 510-19: Typical G&W Viper-S Recloser for 12/16 kV with the CPT Located on the Same Pole (Alternate Method Using Hughes Adapter)

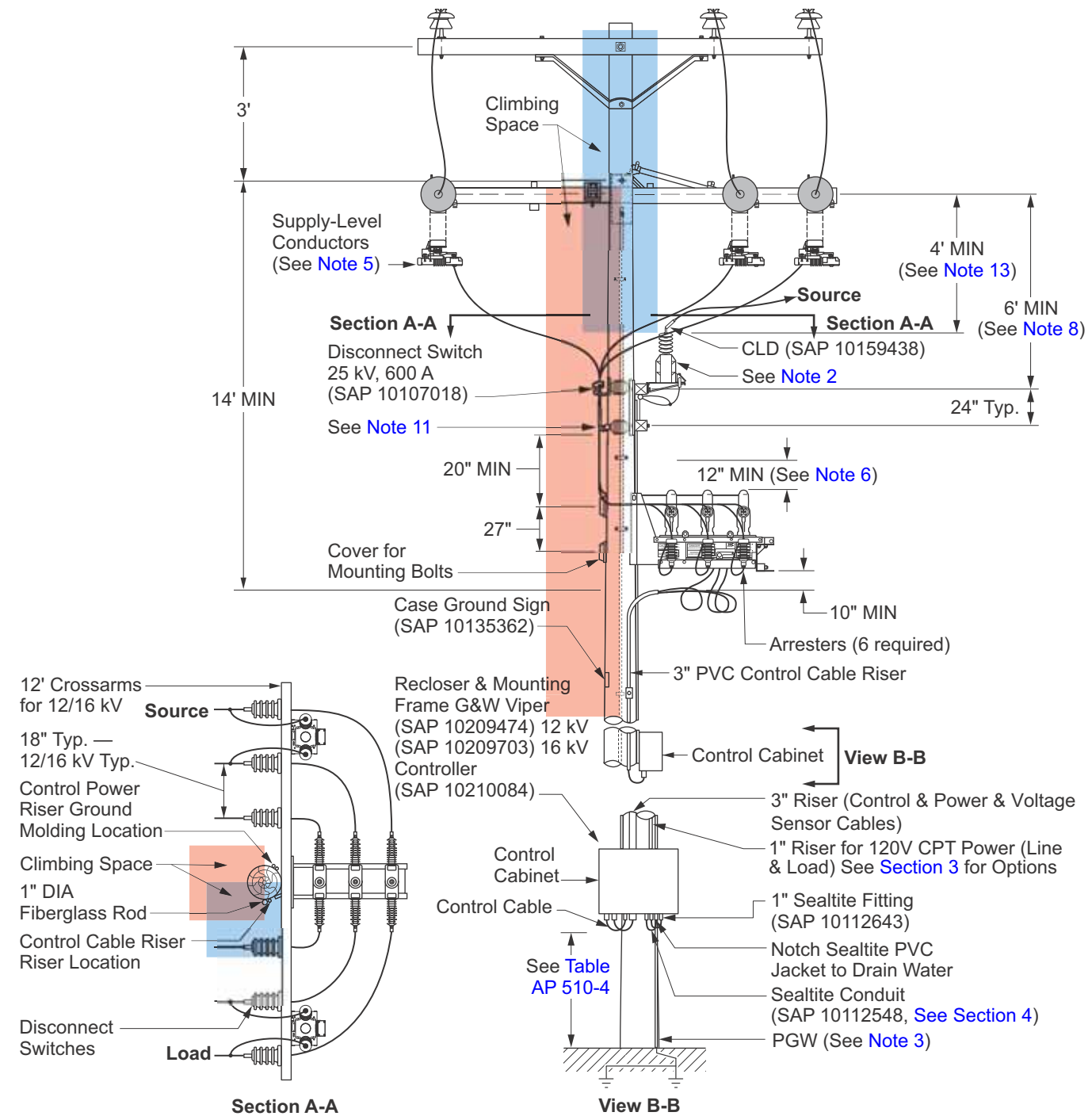

Approved by:
ajf

Three Phase Overhead Remote Electronic Reclosers with Three Phase Voltage Sensing

AP 510

Effective Date:
01-25-2019

What's Changed? Updated notes and references from "RSR" to general "recloser".

Sheet 23 of 29

DOH

Note(s):

1. The CPT shall serve no load other than the recloser and recloser controls.
2. CPT to be rated 980 VA solid dielectric with 120 V fused secondary. CPT (SAP 10105102); CPT bracket (SAP 10104923). Do not ground the CPT bracket.
3. See [Scope AP 510.7](#) for recloser, control, and CPT grounding. Refer to [GR 105](#) for ground conductor and connection requirements.
4. Install wildlife guards on all bushings and leads.
5. Refer to [AP 336](#) for installation requirements for Omni-Rupter bypass switch.
6. Maintain 12-inch minimum separation between high voltage bushings and the CPT mounting bracket, and all secondary leads.
7. Refer to [AP 410](#) and [GR 107](#) for surge arrester installation requirements.
8. Maintain 18-inch minimum (radial) separation between CPT or arrester leads/bushings and the switch blades.
9. To provide a location for grounding at the disconnect switch terminals; leave 6-inches of uncovered conductor on the leads attached to the lower disconnect terminal (that terminate on the recloser).
10. Per [DC 535](#), Wildlife Protection shall be constructed and installed as applicable for insulators, taps, leads, arresters, cable terminations, and equipment bushings.
11. Use two T-Bolt connectors (2/0 AWG — 350 kcmil SAP 10110830; #6 AWG — 2/0 AWG SAP 10110829) per terminal pad to make connections at disconnect switches.
12. Refer to [PO 120](#) for High Voltage sign installation requirements.
13. Taps from the Hughes adapters to disconnect switches shall be formed so as not to obstruct the required climbing space. When possible, the inside (closest to the pole) and middle disconnects should be tapped to the Omni-Rupter phases furthest from the climbing space.
14. Climbing Space required — 36" × 36".

<p>AP 510</p>	<p>Three Phase Overhead Remote Electronic Reclosers with Three Phase Voltage Sensing</p>	<p>Approved by: <i>ajf</i></p>
<p>Sheet 24 of 29 DOH</p>	<p>What's Changed? Updated notes and references from "RSR" to general "recloser".</p>	<p>Effective Date: 01-25-2019</p>

Scope AP 510.5 G&W Viper-S Remote Electronic Reclosers with Three Phase Voltage Sensing for 25 kV Installations

Figure AP 510-20: Typical G&W Viper-S Electronic Reclosers for 25 kV

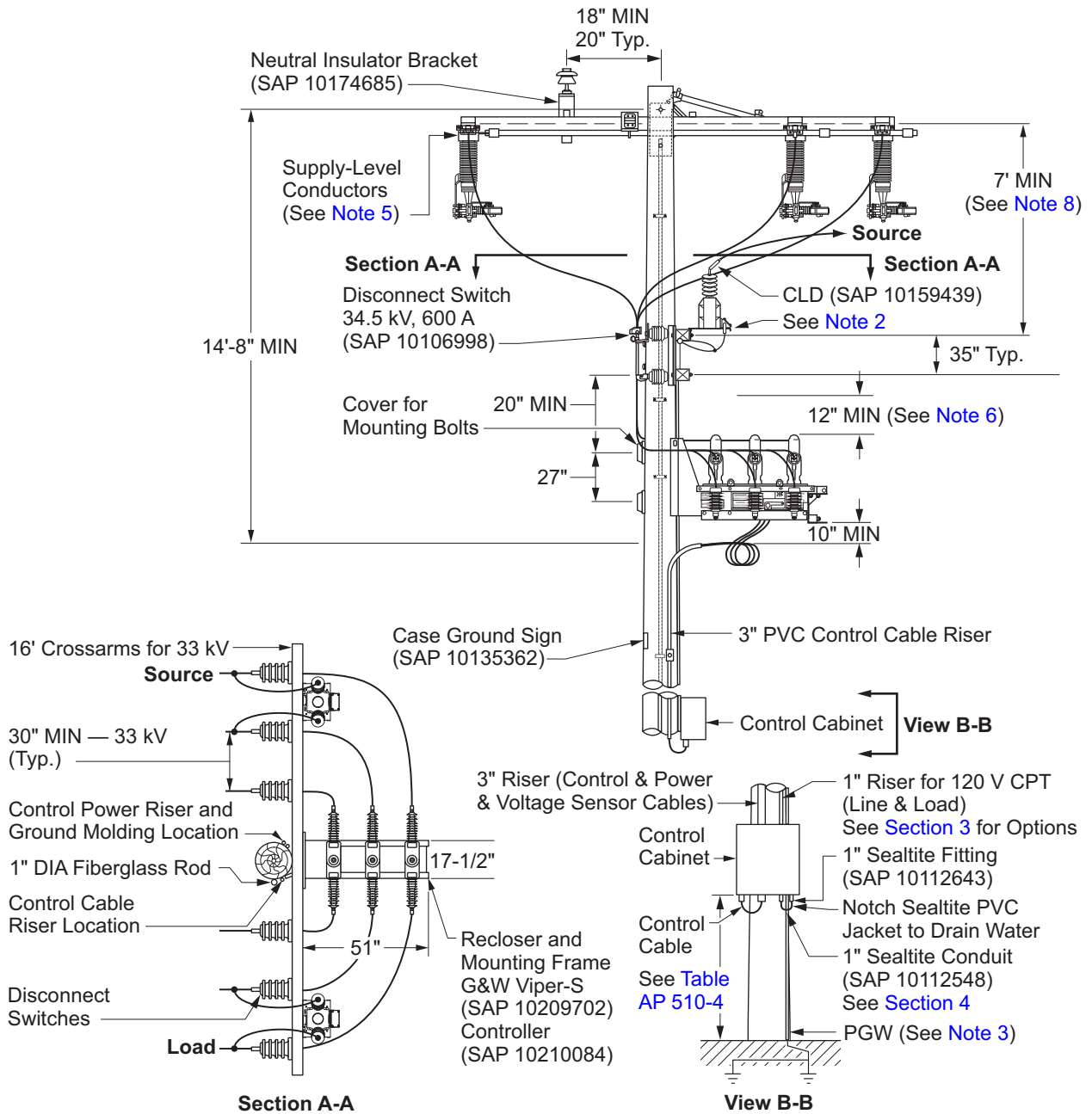

Note(s):

1. The CPT shall serve no load other than the recloser and recloser controls.
2. CPT to be a 1 kVA-solid dielectric with 120 V secondary (SAP 10105069); CPT (SAP 10174769) bracket and transformer. Do not ground the CPT bracket. See Figure AP 510-21 for detail dimensions.

Approved by:

ajj

Three Phase Overhead Remote Electronic Reclosers with Three Phase Voltage Sensing

AP 510

Effective Date:
01-25-2019

What's Changed? New Scope, Figure and notes for 25 kV installation of electronic recloser.

Sheet 25 of 29

DOH

3. See [Scope AP 510.7](#) for recloser, control, and CPT grounding. Refer to [GR 105](#) for ground conductor and connection requirements.
4. Install wildlife guards on all bushings and leads.
5. Refer to [AP 338](#) for installation requirements for Alduti-Rupter bypass switch, the supply conductors shall be dead-ended to the switch crossarm.
6. Maintain 12-inch minimum separation between high voltage bushings and the CPT mounting bracket, and all secondary leads.
7. Refer to [AP 410](#) and [GR 107](#) for surge arrester installation requirements.
8. Maintain a 24-inch minimum (radial) separation between CPT or arrester leads/bushings and the switch blades.
9. To provide a location for grounding at the disconnect switch terminals; leave 6-inches of uncovered conductor on the leads that terminate on the recloser.
10. Per [DC 535](#), Wildlife Protection shall be constructed and installed as applicable for insulators, taps, leads, arresters, cable terminations, and equipment bushings.
11. Refer to [PO 120](#) for High Voltage sign installation requirements.

Figure AP 510–21: Insulator Mounting Bracket for 25 kV Installations

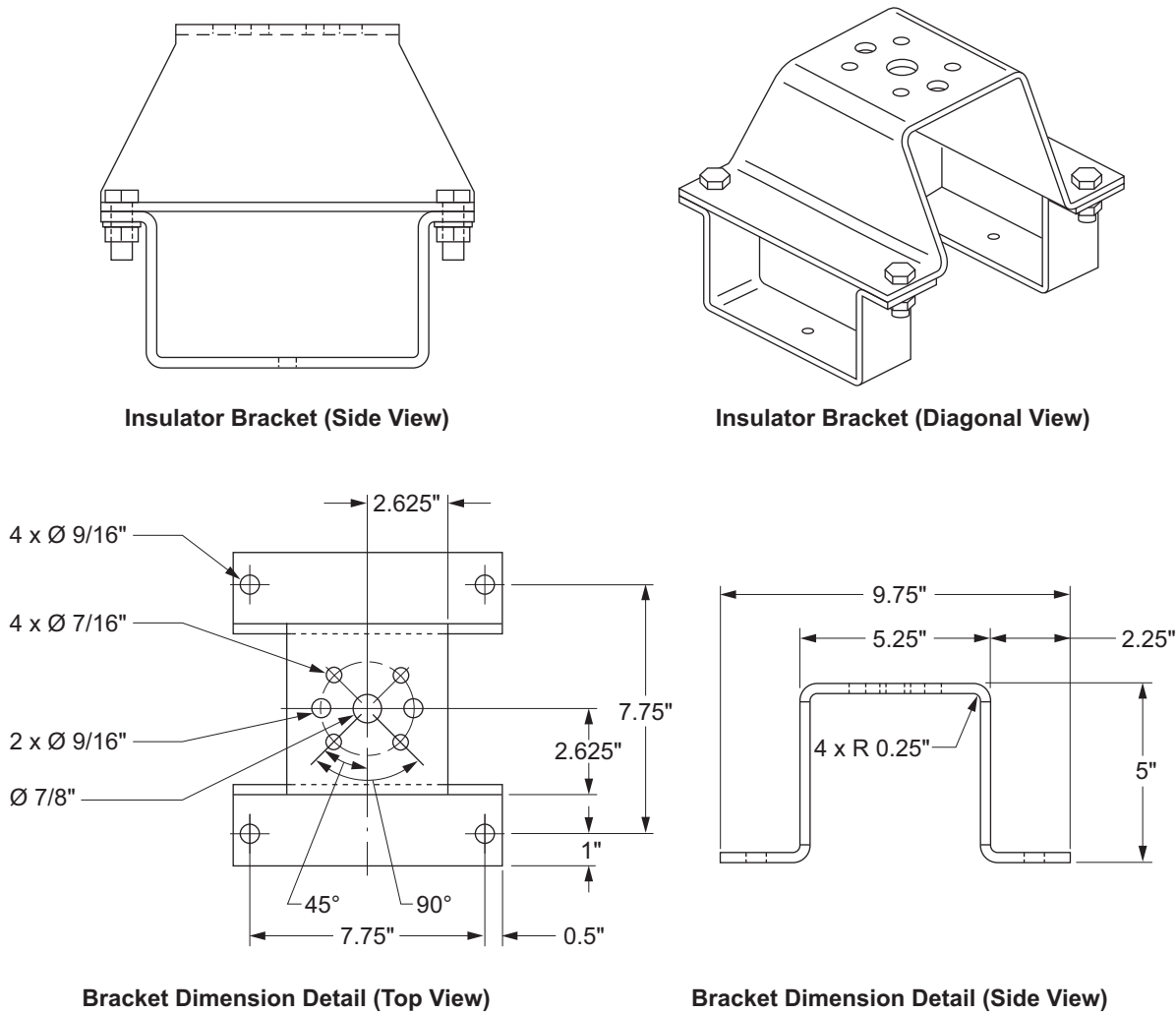

Scope AP 510.6 G&W Viper-S Remote Electronic Reclosers with Three Phase Voltage Sensing for 33 kV Installations

Figure AP 510-22: Typical G&W Viper-S Electronic Reclosers for 33 kV

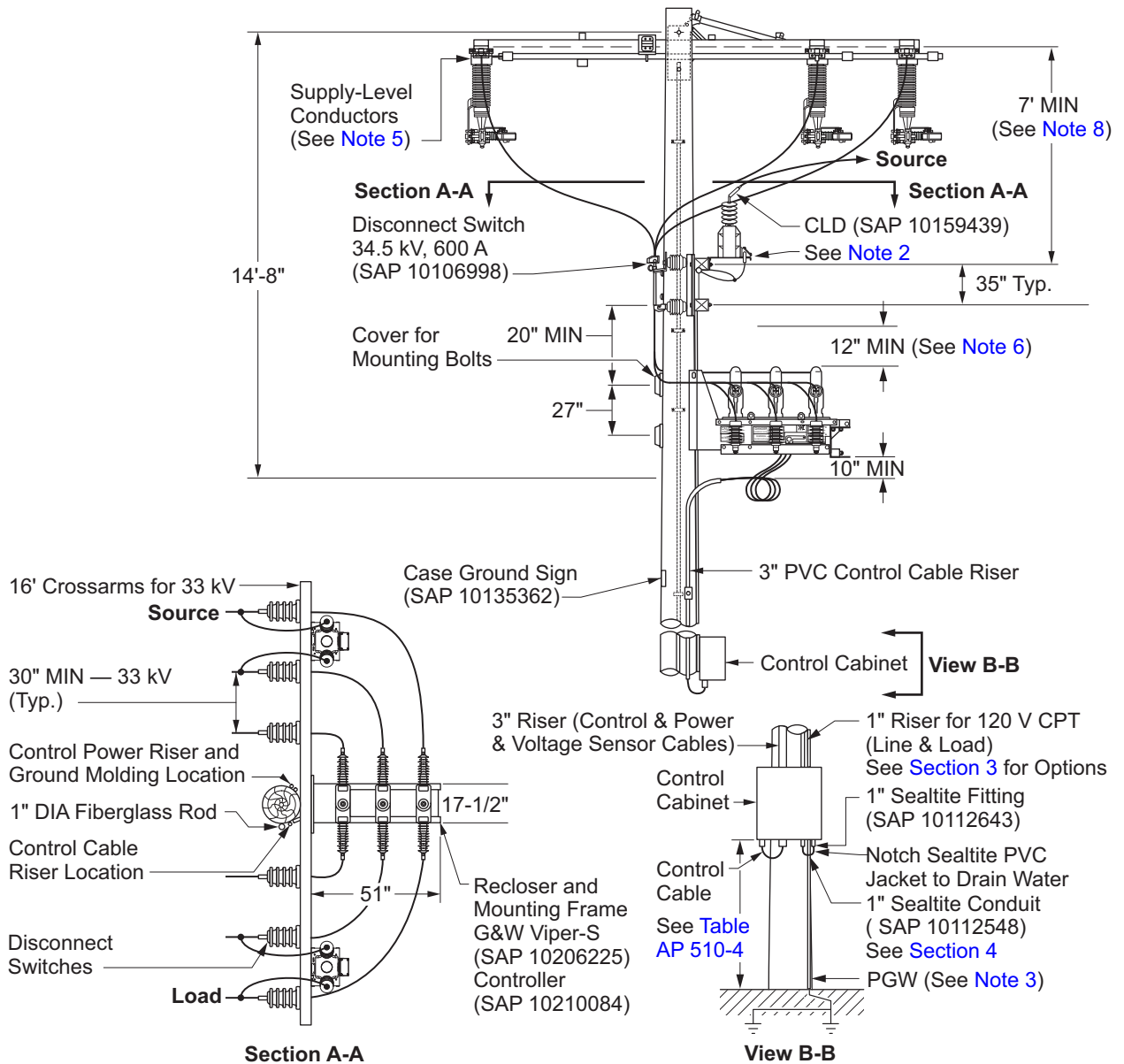

Note(s):

1. The CPT shall serve no load other than the recloser and recloser controls.
2. CPT to be a 1 kVA -solid dielectric with 120 V fused secondary. CPT (SAP 10167672), CPT bracket (SAP 10067317),
3. See [Scope AP 510.7](#) for AR, control, and CPT grounding. Refer to [GR 105](#) for ground conductor and connection requirements.
4. Install wildlife guards on all bushings and leads.

Approved by:

ajf

Three Phase Overhead Remote Electronic Reclosers with Three Phase Voltage Sensing

Effective Date:
01-25-2019

What's Changed? New Scope, Figure and notes for 33 kV installation of electronic recloser.

AP 510

Sheet 27 of 29

DOH

5. Refer to [AP 338](#) for installation requirements for Alduti-Rupter bypass switch, the supply conductors shall be dead-ended to the switch crossarm.
6. Maintain 12-inch minimum separation between high voltage bushings and the CPT mounting bracket, and all secondary leads.
7. Refer to [AP 410](#) and [GR 107](#) for surge arrester installation requirements.
8. Maintain a 24-inch minimum (radial) separation between CPT or arrester leads/bushings and the switch blades.
9. To provide a location for grounding at the disconnect switch terminals; leave 6-inches of uncovered conductor on the leads that terminate on the recloser
10. Per [DC 535](#), Wildlife Protection shall be constructed and installed as applicable for insulators, taps, leads, arresters, cable terminations, and equipment bushings.
11. Refer to [PO 120](#) for High Voltage sign installation requirements.

AP 510	Three Phase Overhead Remote Electronic Reclosers with Three Phase Voltage Sensing	Approved by: <i>a/j</i>
Sheet 28 of 29	What's Changed? New Scope, Figure and notes for 33 kV installation of electronic recloser.	Effective Date:
DOH		01-25-2019

Scope AP 510.7 Control Cable and Grounding Connections

Figure AP 510-23: Typical Connections for Recloser with the CPT Located on the Same Pole

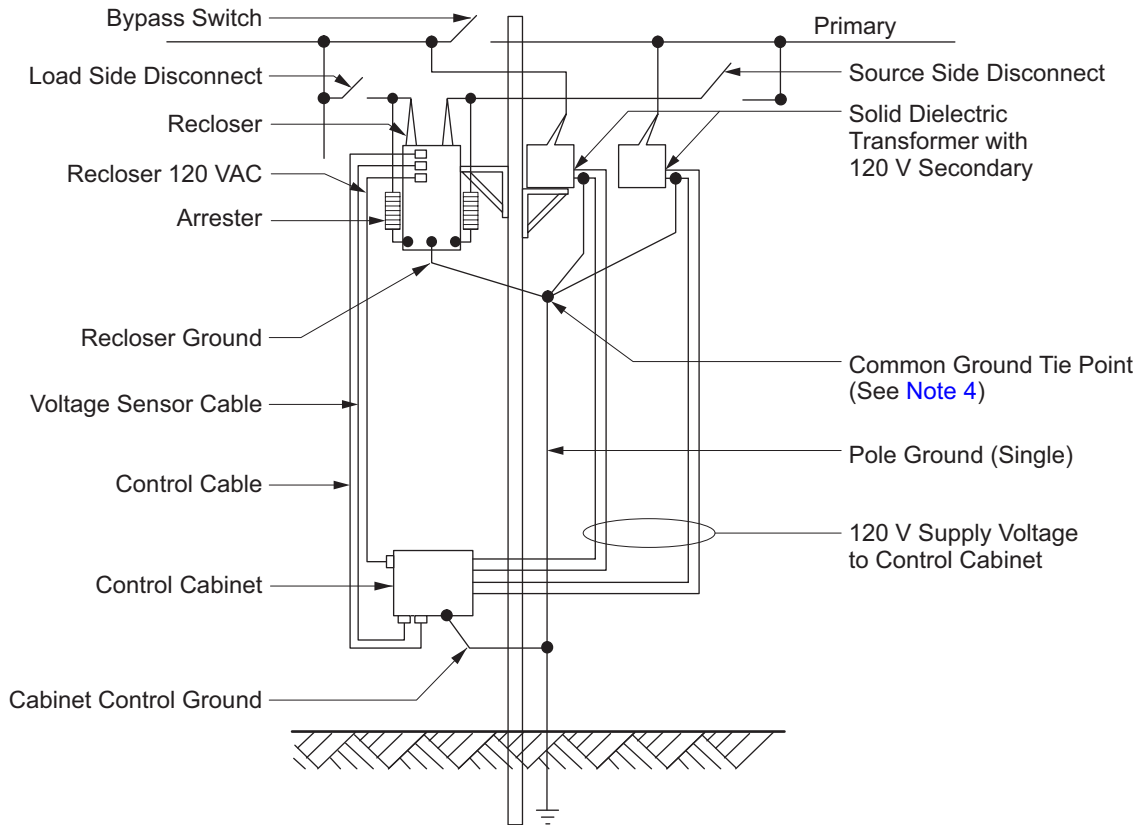

Note(s):

1. The CPT shall serve no load other than the recloser and recloser control.
2. Surge arresters, secondary neutrals, recloser tank and frame, and control cabinet shall be connected to the same ground to minimize any potential ground differences between equipment.
3. Per [DC 535](#), Wildlife Protection shall be constructed and installed as applicable for insulators, taps, leads, arresters, cable terminations, and equipment bushings.

Approved by: 	Three Phase Overhead Remote Electronic Reclosers with Three Phase Voltage Sensing	AP 510
Effective Date: 01-25-2019	What's Changed? Updated notes and references from "RSR" to general "recloser".	Sheet 29 of 29 DOH

This page intentionally left blank.

AP 620P Cleaveland/Price Linescope Lineprobe Sensor for 12 kV and 16 kV 3-Phase 4-Wire Horizontal Construction Applications

Scope AP 620P.1 Installation Procedure for Cleaveland/Price Linescope Lineprobe Sensor for 12 kV and 16 kV 3-Phase 4-Wire Horizontal Construction Applications

1.0 General Description

The purpose of the Cleaveland/Price Linescope Overhead Line Monitoring System is to remotely monitor the status of overhead distribution circuits, providing 3-phase voltage and current measurements along with kW and kVAR telemetry data through wireless communication to the RTU in ADMO Switch Controls for communication to the Distribution Management System (DMS) system.

The 3-phase telemetry data will assist personnel responding to circuit faults, distribution equipment-related outages, circuit over-load conditions, circuit troubleshooting, and circuit reliability issues.

Currently, the Linescope Overhead Line Monitoring System deployment scope is specified by Field Engineering, with targeted installation locations meeting the following criteria:

- System Voltages: 12 kV and 16 kV
- System: 3-Phase, 4-Wire
- Horizontal Overhead Line Construction
- Line Conductor Size: 1/0 AWG to 653.9 kcmil (fits conductors up to a maximum of 1.2 inches in diameter).
- Sensors installed on overhead conductors within the maximum transmitter range as specified in [Table AP 620P-3](#).
- Sensors installed on opposite side of RCS switch from the control power transformer and with the 'Line' label oriented towards the switch.
- Existing or Anticipated high penetration of Distributed Generation Resources on circuit.
- Sensors installed outside of Bulletin 322 areas.

The Cleaveland/Price Linescope System detects, records, and transmits the following data:

- 3-Phase Line and Neutral Current
- 3-Phase Line Voltage
- kW and kVAR per phase
- Harmonics per phase
- Power Factor per phase

1.1 Linescope Overhead Line Monitoring System

Consists of three Lineprobe sensors, with one Lineprobe sensor installed per phase and one ADMO control located within 150 feet (see [Table AP 620P-1](#)), line of sight, from the three Lineprobe overhead mounted sensors. To facilitate wireless communication between Lineprobe sensors and ADMO control, a Linescope antenna is mounted on the ADMO control, and is connected to the RTU 3211LS, which provides SCADA communication via DMS. The Lineprobe sensors utilize voltage-based line energy harvesting to remain energized even with no current flow on the high voltage line. Each sensor weighs approximately 6.5 pounds per unit.

Approved by: 	Cleaveland/Price Linescope Lineprobe Sensor for 12 kV and 16 kV 3-Phase 4-Wire Horizontal Construction Applications	AP 620P
Effective Date: 01-25-2019	What's Changed?	Sheet 1 of 19 DOH

The following components are included with each Linescope RCS Retrofit kit:

Table 620P-1: List of Parts for Linescope (SAP 10207732) and V2 Upgrade (SAP 10209226)

Standard Linescope Parts	Quantity	Use
15 kV Line Probe Assembly for LN Installation	3	Required
RTU3211LS	1	Required
Coax Antenna Cable U.FL Female to N-Male; 30"	1	Required
900 MHz antenna (include Gasket, Star Washer, & Nut)	1	Required
Nylon Washer (Antenna Insert)	1	Required
Wire Tie 5-5/8"	5	Required
Phase SN label decal (Documentation)	1	Required
Fault LED Wiring Harness	1	Required
Antenna Extension Kit (includes 5/8" bulkhead adapter, 15' coaxial cable, antenna extension bracket)	1	Required
6-32 × 3/8" Thumb Screw (Reuse Existing)	3	Spare
#6 Neoprene O-Ring (Reuse Existing)	2	Spare
6-32 × 3/4" Nylon Standoff (Reuse Existing)	2	Spare
6-32 × 3/4" Zn Plated Brass Standoff (Reuse Existing)	2	Spare
6-32 × 3/8" Phillips Pan Head Screw (Reuse Existing)	2	Spare
V2 ADMO RTU Upgrade Parts	Quantity	Use
RTU 1000 to RTU321X Adapter Board	1	Required
RTU321X Cover Plate	1	Required
6-32 × 3/8" Thumb Screw	4	Required
#6 Neoprene O-Ring	4	Required
6-32 × 5/8" Zn Plate Brass Standoff	7	Required

2.0 Pre-Installation Instructions for Preparing the Linescope RCS Retrofit Kit Prior to Installation.

Prior to installing Lineprobe sensors on overhead line, perform the following:

- STEP 1. Contact the Distribution Automation Hotline at 714-285-4325 when installing, relocating, or removing automated equipment.
- STEP 2. Verify the rated voltage listed on the Lineprobe sensor nameplate is applicable for the intended circuit voltage application (see [Table AP 620P-2](#)).
- STEP 3. Verify each Lineprobe is reading the proper resistance between the test point on the probe body and the end of the ground cable. See [Table AP 620P-2](#) for target resistances with respect to sensor voltage class. See [Figure AP 620P-1](#) for resistance measurement test points. Retain the resistance measurement readings to provide during the Distribution Automation End-Point Test (EPT) procedure.

Table 620P-2: Lineprobe Ohmic Target Resistance

Linescope Sensor Voltage Class	Application Voltage	Target Resistance (+/- 5%)
15 kV	12 kV, 16 kV	5 MΩ



If the resistance for a particular Lineprobe sensor does not measure within $\pm 5\%$ of the nominal resistance ($\pm 250 \text{ k}\Omega = 5,250,000\Omega - 4,750,000\Omega$), **do not install the sensor.**

Figure 620P-1: Lineprobe Ohmic Resistance Measurement Test Points

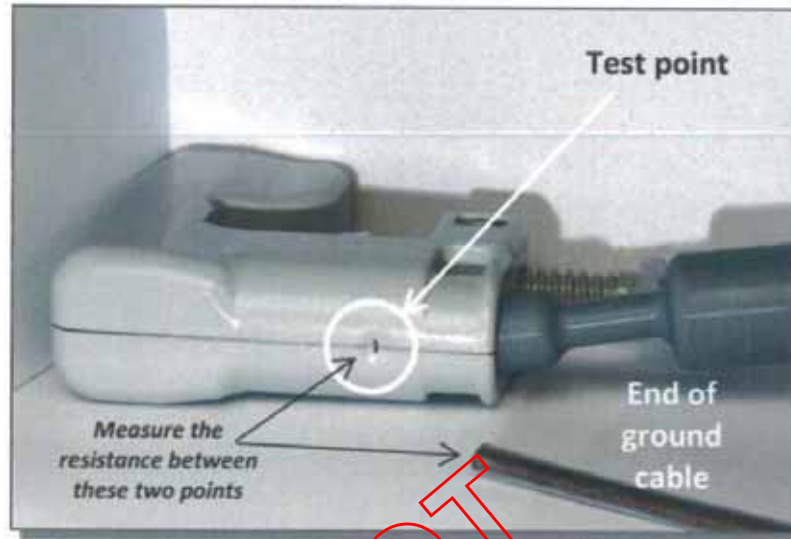

Do not mismatch any of the Lineprobe sensors from one system kit with that of another kit. The three Lineprobe sensors are factory preset and configured to each other. Contact Distribution Automation Hotline for configuration support.

- STEP 4. Verify the required components detailed in [Table AP 620P-1](#). If RCS Linescope Retrofit is intended for an existing ADMO RCS control equipped with an RTU 1000, a new RTU 3211LS is required, see [Subsection 3.1](#) and [Subsection 3.3](#).
- STEP 5. Conduct Phase Identification procedure at sensor installation location, to identify and label the A phase, B phase and C phase per DOM TE-14.
- STEP 6. Install Clamp Star splice shunt on any automatic splices on overhead conductor span where Linescopes will be installed, see [CO 470](#) for additional details.

Approved by: <i>ajf</i>	Cleveland/Price Linescope Lineprobe Sensor for 12 kV and 16 kV 3-Phase 4-Wire Horizontal Construction Applications	AP 620P
Effective Date: 01-25-2019	What's Changed?	Sheet 3 of 19
		DOH

3.0 Installation Instructions for Linescope

3.1 RTU Replacement for existing V3 ADMO's equipped with RTU 1000 only, for V2 ADMO see [Subsection 3.2](#).

V3 ADMO RCS controls equipped with RTU 1000 (factory installed in ADMO controls prior to 2014) require replacement of RTU 1000 with an RTU 3211LS to enable communication between Lineprobe sensors and ADMO control. See [Figure AP 620P-2](#) for identification of RTU model. An ADMO control equipped with an RTU 3211LS does not require RTU replacement. Steps to replace RTU 1000 to RTU 3211LS as follows:

- STEP 1. Contact the Distribution Automation Hotline at 714-285-4325 when installing, relocating, or removing automated equipment.
- STEP 2. Complete Pre-Installation Instructions (see [Section 2.0](#)).
- STEP 3. Remove the manual handle from the ADMO control.
- STEP 4. Insert Lockout Pin to lock plunger shaft.
- STEP 5. Ensure that the ADMO local controls are in LOCAL and NON-AUTO.
- STEP 6. Remove AC fuses.
- STEP 7. Remove DC fuse.
- STEP 8. Disconnect all cables to the control module, including 40 PIN connector, LVA sensor, and RTU serial communication cable.
- STEP 9. Remove control module faceplate by removing the yellow thumbscrews, LVA locknut, and red auto test button.
- STEP 10. Remove the two nylon standoff posts and two screws (save these items) then carefully detach the RTU 1000 module away from the face of the control module.
- STEP 11. Carefully seat the new RTU 3211LS into the same position previously occupied by the RTU 1000.
- STEP 12. Reattached the nylon standoff posts, machine screws, control module faceplate, and yellow thumbscrews.
- STEP 13. Reconnect all cables, hex LVA nut, and red LVA test button.

Figure 620P-2: Identification of RTU Model on a V3 ADMO



RTU Board



Upon removal of RTU faceplate, RTU Board, right side.
Model number detail in-circled in red.

3.2 RTU Replacement for V2 ADMO's equipped with RTU 1000 only

V2 RCS ADMO controls equipped with RTU 1000 (factory installed in ADMO controls prior to 2014) require replacement of RTU 1000 with an RTU 3211LS and also installation of a V2 conversion kit to enable communication between Lineprobe sensors and ADMO control. See [Figure AP 620P-3](#) for identification of RTU model and V2 ADMO.

Steps to replace RTU 1000 with RTU 3211LS, including retrofit kit installation are as follows:

- STEP 1. Contact the Distribution Automation Hotline at 714-285-4325 when installing, relocating, or removing automated equipment.
- STEP 2. Complete Pre-Installation Instructions (see [Section 2.0](#)).
- STEP 3. Remove the manual handle from the ADMO control.
- STEP 4. Insert Lockout Pin to lock plunger shaft.
- STEP 5. Ensure that the ADMO local controls are in LOCAL and NON-AUTO.
- STEP 6. Remove AC fuses.
- STEP 7. Remove DC fuse.
- STEP 8. Locate the V2 RTU module in the right side compartment of the ADMO mounted on the vertical face of the compartment.
- STEP 9. Remove all cables, including the serial cable, the two position Molex connector, and the 16-pin position Molex connector on the leading (closest) side of the RTU.
- STEP 10. Remove the three machine screws that secure the clear plexi-glass faceplate of the RTU module and save the hardware.
- STEP 11. Detach the RTU. Do not remove the four plastic standoffs, they shall remain attached to the vertical surface on the ADMO and be reused.
- STEP 12. Mount the adapter board onto the side wall by placing it onto the top of the four existing standoffs that had remained in place. Secure the adapter board to the plastic standoffs with the four new metal standoffs.
- STEP 13. Mount the RTU 3211LS onto the adapter board by aligning the plastic wiring connectors. Proper alignment shall have the communication connectors closest the ADMO door. Compress the RTU until the RTU settles firmly into the Molex connectors.
- STEP 14. Secure the RTU 3211LS onto the metal standoffs using the three metal standoffs and a yellow thumbscrew. The thumbscrew shall be installed in the upper left corner.
- STEP 15. Attach the aluminum cover faceplate to the face of the RTU 3211LS using the remaining thumbscrews.
- STEP 16. Reconnect all associated cables including power, serial (radio), and telemetry cables.



NOTE

If replacing a failed RTU 1000 in a CPI V2 ADMO, but without addition of a Linescope conversion please order the V2 conversion kit (SAP 10209226) and a new RTU 3211LS (SAP 10100773).

Approved by: 	Cleveland/Price Linescope Lineprobe Sensor for 12 kV and 16 kV 3-Phase 4-Wire Horizontal Construction Applications	AP 620P Sheet 5 of 19
Effective Date: 01-25-2019	What's Changed?	

Figure 620P-3: Identification of V2 Model



Identification of V2 RTU 1000 & Completed Final V2 RTU3211LS Installation

Figure 620P-4: Exploded View of V2 Kit for Conversion

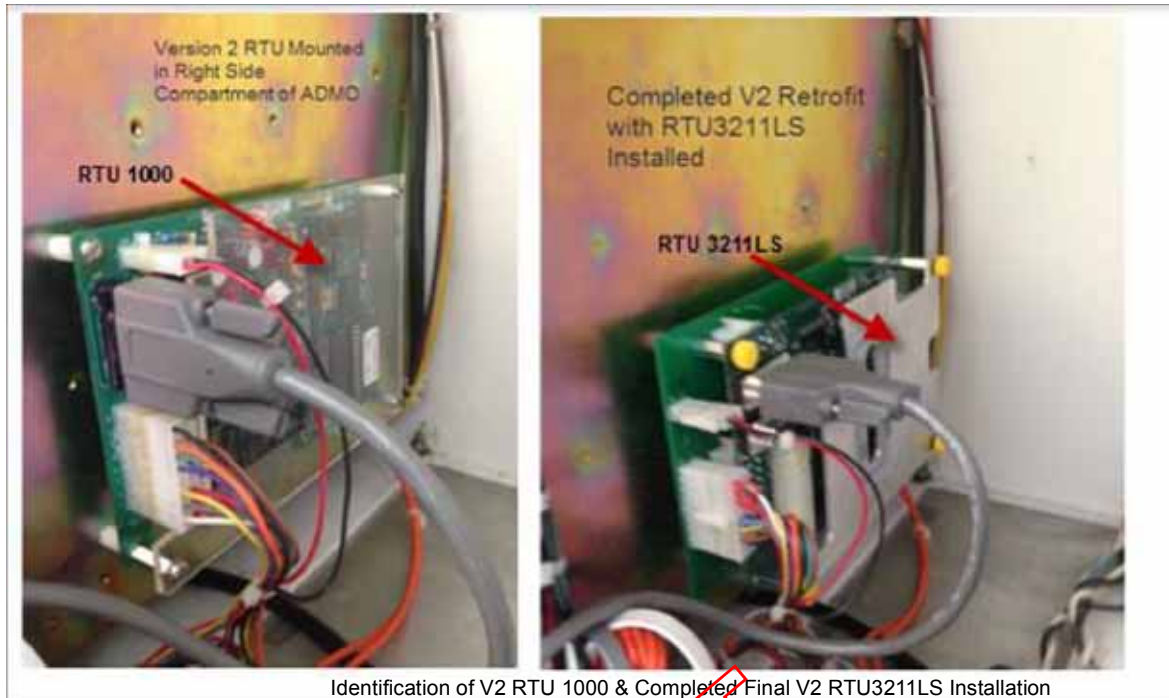

AP 620P

Cleveland/Price Linescope Lineprobe Sensor for 12 kV and 16 kV 3-Phase 4-Wire Horizontal Construction Applications

Approved by:

ajf

Sheet 6 of 19

What's Changed?

Effective Date:

DOH

01-25-2019

Figure 620P-5: Select Illustrated Installation Steps

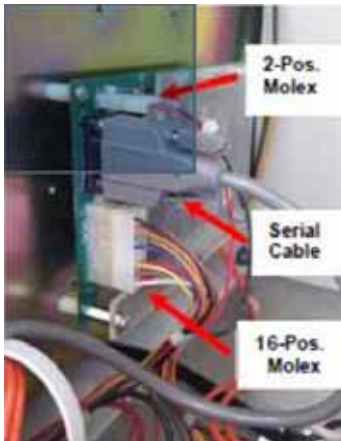

STEP 1. Remove connectors.



STEP 2. Remove (3) screws and plastic cover.



STEP 3. Remove (3) standoffs and screw.



STEP 4. Leave (4) plastic standoffs on side wall.

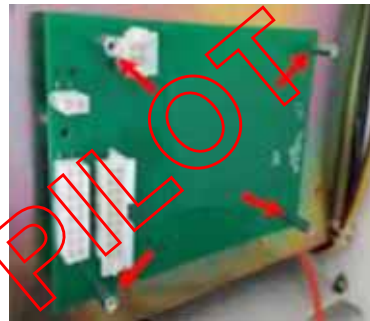

STEP 5. Mount adapter board to the cabinet side wall.



STEP 6. Mount new RTU3211.



STEP 7. Secure RTU3211 to the adapter board.



STEP 8. Attach aluminum cover plate.



STEP 9. Plug the connectors back in.

Approved by:

ajf

Cleveland/Price Linescope Lineprobe Sensor for 12 kV and 16 kV 3-Phase 4-Wire Horizontal Construction Applications

Effective Date:

01-25-2019

What's Changed?

AP 620P

Sheet 7 of 19

DOH

3.3 Linescope Antenna Installation

- STEP 1. Contact the Distribution Automation Hotline at 714-285-4325 when installing, relocating, or removing automated equipment.
- STEP 2. Complete Pre-Installation Instructions (see [Section 2.0](#)).
- STEP 3. Verify manual handle from the ADMO control removed.
- STEP 4. Verify Lockout Pin Inserted to lock plunger shaft.
- STEP 5. Verify that the ADMO local controls are in LOCAL and NON-AUTO.
- STEP 6. Verify that the AC fuses are removed.
- STEP 7. Verify that the DC fuse is removed.
- STEP 8. Install tape on the underside of the control beneath the future antenna hole location to prevent metal shavings from entering the control assembly during drilling of the antenna hole. Drill 3/4-inch hole on the ADMO enclosure where the Linescope antenna will be mounted. See [Figure AP 620P-6](#) for details on placement of the Linescope antenna.

Figure 620P-6: Linescope Antenna Placement (Top View of ADMO Control Cabinet)

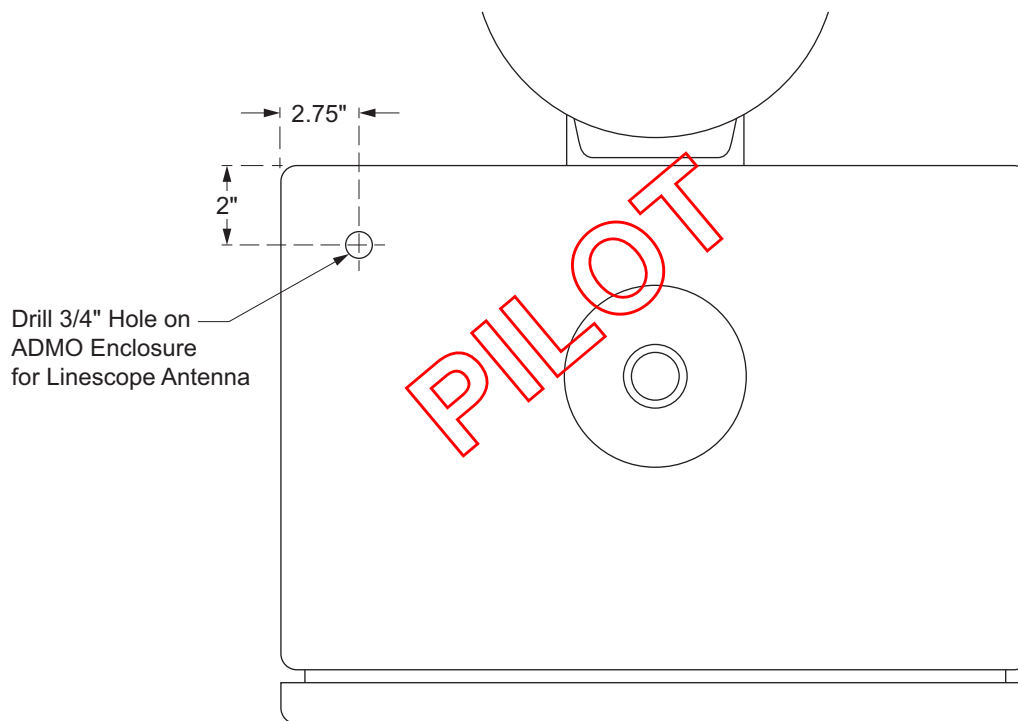

- STEP 9. Clean the top surface of the ADMO to remove residue and grime. Insert the nylon busing into the mounting hole inside of the ADMO.
- STEP 10. Mount antenna extension bracket to the unistrut attached to the 2-inch diameter PVC using the two lag screws and ensure antenna location meets guidelines specified in [Figure AP 620P-7](#). If there is no unistrut installed on the pole, follow the antenna location guidelines specified in [Figure AP 620P-7](#).

Figure 620P-7: Antenna Installation Details

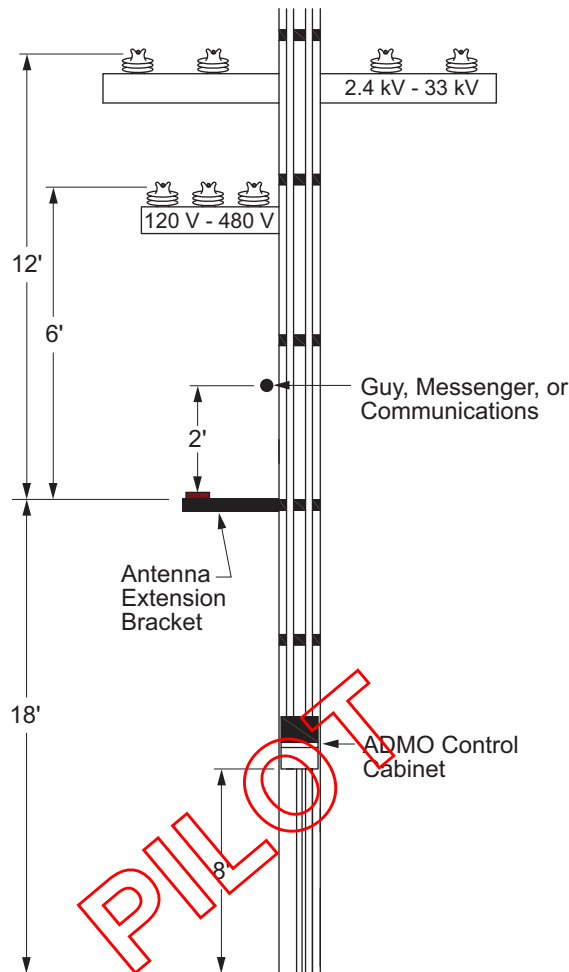

Note(s):

1. To allow for appropriate climbing space, antenna should be installed in the same two climbing quadrants as the ADMO.
 - STEP 11. Connect PVC elbows on the top and bottom of the 10-foot PVC conduit using PVC couplers.
 - STEP 12. Mount the PVC conduit on the pole below the extension bracket.
 - STEP 13. Install antenna on top of mounting bracket.
 - STEP 14. Insert nylon bushing, star lock washer, mounting nut and hand tighten in that order below mounting bracket to ensure bracket is ungrounded.
 - STEP 15. Run coaxial cable down conduit (bulkhead connector side first) through elbow.
 - STEP 16. Screw coaxial cable to antenna thread and hand tighten.
 - STEP 17. Insert bulkhead connector through previously drilled hole.
 - STEP 18. Insert the star lock washer, mounting nut over the bulkhead connector threads and hand tighten.
 - STEP 19. Verify that the base of the bulkhead connector forms a weatherproof seal with the surface of the ADMO enclosure.

Approved by: <i>ajf</i>	Cleveland/Price Linescope Lineprobe Sensor for 12 kV and 16 kV 3-Phase 4-Wire Horizontal Construction Applications	AP 620P
Effective Date: 01-25-2019	What's Changed?	Sheet 9 of 19
		DOH

- STEP 20. Screw the coaxial cable connector onto the bulkhead connector.
- STEP 21. Screw the coaxial cable connector from the RTU onto the bulkhead connector.
- STEP 22. Disconnect the RS232 and power cable from the RTU then remove faceplate to RTU by removing the Auto/Non-Auto switch proximity retaining nut, the Auto Test red button, and the three yellow thumb screws.
- STEP 23. Snap the coaxial cable connector from the antenna to the coaxial button connector at the top edge of the RTU 3211LS, see [Figure AP 620P-8](#) for details.

Figure 620P-8: Linescope Antenna Cable Connection to Coaxial Connector on RTU 3211LS

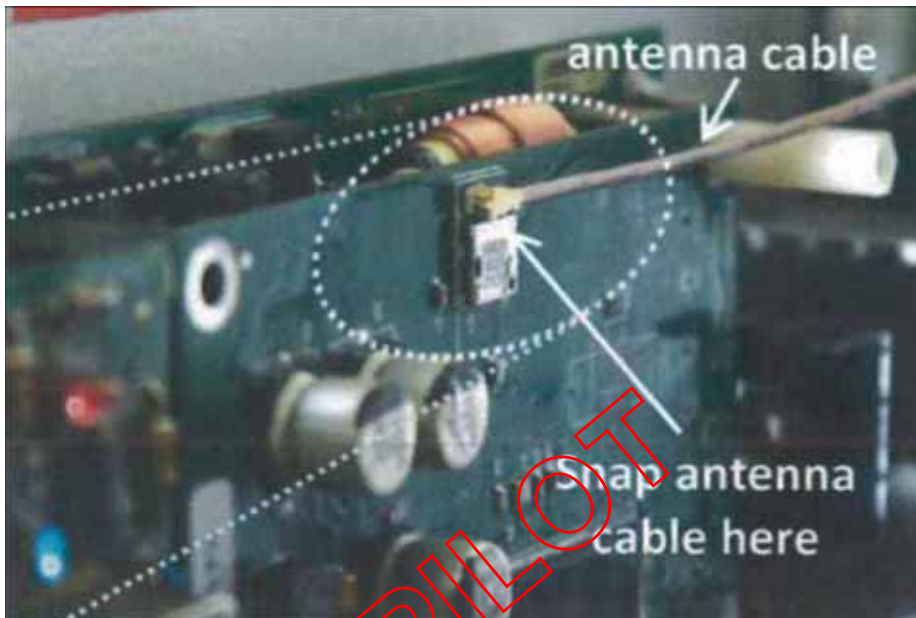

- STEP 24. Using one of the available holes located on either side of the button connector on the RTU 3211LS, zip-tie the connector as required to provide adequate retention support for cable connection. The hole used will depend on which direction cable is routed.
- STEP 25. Re-install faceplate, securing with the yellow thumb screws, switch retaining nut and red button for LVA interface.
- STEP 26. Reconnect the RS232 and power cable to the RTU.

Figure 620P-9: Complete Installation of Antenna Extension



Approved by: 	Cleveland/Price Linescope Lineprobe Sensor for 12 kV and 16 kV 3-Phase 4-Wire Horizontal Construction Applications	AP 620P
Effective Date: 01-25-2019	What's Changed?	Sheet 11 of 19 DOH

3.4 Wiring Harness Installation for 120 VAC Status Indication

Installation of this harness shall provide for analog reading of control power transformer 120 VAC magnitude by the RTU. New ADMOs shipped in 2017, shall be factory equipped with this harness, however legacy ADMOs manufactured prior to 2017 shall require upgrade to enable the added telemetry.

Steps to install the 120 VAC wiring harness.

- STEP 1. Contact the Distribution Automation Hotline at 714-285-4325 when installing, relocating, or removing automated equipment.
- STEP 2. Complete Pre-Installation Instructions (see [Section 2.0](#)).
- STEP 3. Verify manual handle from the ADMO control removed.
- STEP 4. Verify Lockout Pin Inserted to lock plunger shaft.
- STEP 5. Verify that the ADMO local controls are in LOCAL and NON-AUTO.
- STEP 6. Verify that the AC fuses are removed.
- STEP 7. Verify that the DC fuse is removed.



NOTE Follow APM rules associated with working in a control enclosure with exposed 120 VAC. Preference is to de-energize the control as installation of the wiring harness shall require contact with the Line side for the 120 VAC fuse clip terminals.

- STEP 8. Connect the hot and neutral spade connector onto the matching hot and neutral terminals of the 120 VAC fuse terminals. Orientation per [Figure AP 620P-11](#) and [Figure AP 620P-12](#).

Figure 620P-10: Wiring Harness Cable for Retrofit Provision of 120 VAC Telemetry



Multiconductor harness cable for 120 VAC Telemetry

Figure 620P-11: Wiring Harness Cable Terminals Being Attached



Figure 620P-12: Wiring Harness Cable Terminals Attached



Approved by: 	Cleveland/Price Linescope Lineprobe Sensor for 12 kV and 16 kV 3-Phase 4-Wire Horizontal Construction Applications	AP 620P
Effective Date: 01-25-2019	What's Changed?	Sheet 13 of 19 DOH

STEP 9. Route wiring harness along the bottom of the enclosure and connect the 8 pin Molex Connector into the RTU 3211LS matching terminal on the side of the RTU. On V2, RTU connection is made on the bottom of RTU module. On V3, the wiring harnesses' RTU connection is made on the side of the control module opposite door (see [Figure AP 620P-13](#)).

Figure 620P-13: Connector Location for 8 Pin Molex on RTU 3211LS for V3



NOTE

The 4 Pin molex connector at the center of the wiring harness is not used at this time.

- STEP 10. Install DC Fuse.
- STEP 11. Install AC Fuses.
- STEP 12. Remove lockout pin to unlock plunger shaft.
- STEP 13. Return manual handle to ADMO control.

3.5 Installation of Linescope Lineprobe Sensors

Each Linescope Lineprobe sensor is pre-configured for its respective phase (A, B, C) with a label that identifies the assigned phase and serial number.

The Linescope is also pre-configured with respect to its LINE and LOAD side, and labeled to identify the respective sides. See [Figure AP 620P-14](#) for LINE/LOAD side labeling designations.

The Lineprobes shall be installed with the "LINE" label oriented to face the switch. The Lineprobe shall be installed on the opposite side of the switch from where the control power transformer is tapped up. The Lineprobes shall be installed less than 150 feet line of sight distance to the Linescope Antenna at the ADMO. Consult [Table AP 620P-3](#) for maximum distance.

Figure 620P-14: Linescope Lineprobe Sensor LINE/LOAD Labeling

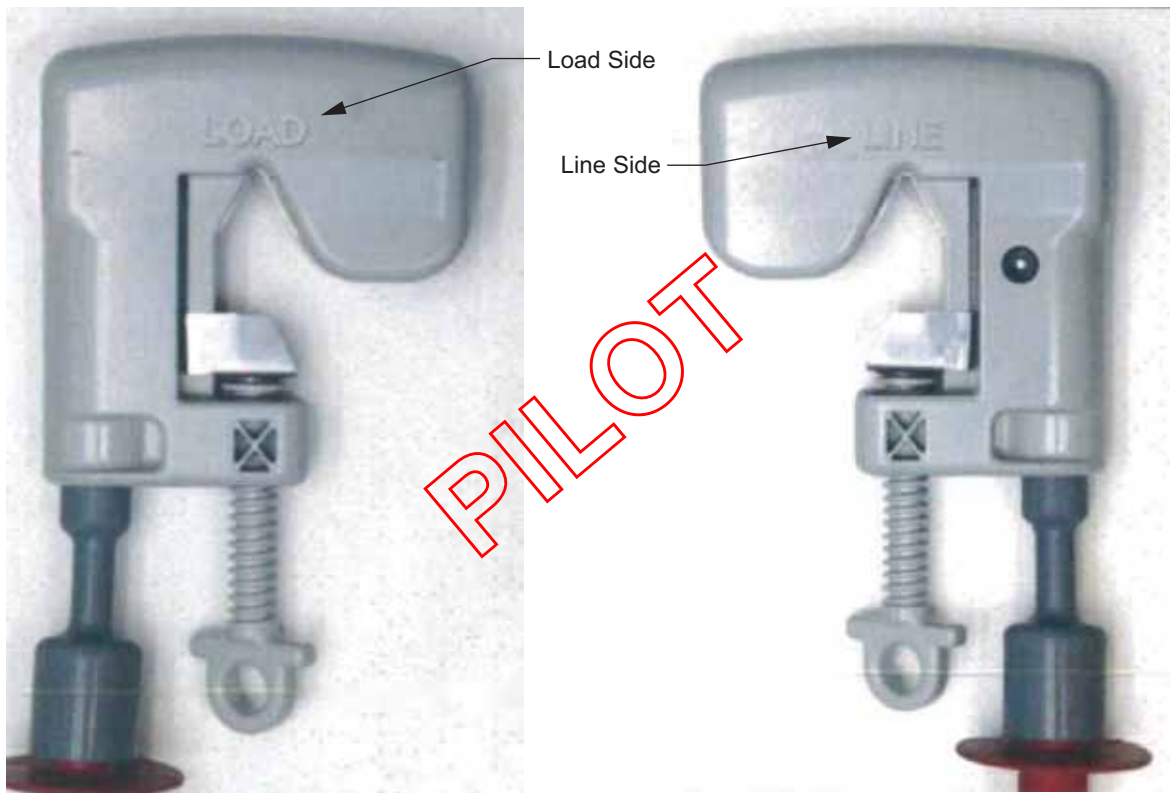

NOTE The ground cable **MUST** be fully secured **BEFORE** the Linescope Lineprobe can be installed on the power line.

- STEP 1. Complete Pre-Installation Instructions for Preparing the Linescope RCS Retrofit Kit Prior to Installation (see [Section 2.0](#)).
- STEP 2. Using the appropriate ground cable length measurements for connection between tail and neutral conductor tap at installation point, mark the cable and cut it at the marked point. Maintain clearances per G.O. 95 (see [Figure AP 620P-17](#)).

Approved by: 	Cleveland/Price Linescope Lineprobe Sensor for 12 kV and 16 kV 3-Phase 4-Wire Horizontal Construction Applications	AP 620P
Effective Date: 01-25-2019	What's Changed?	Sheet 15 of 19 DOH



All portions of Lineprobe sensor must be treated as energized, refer to APM Rules 205, 207, and 208 and all other applicable SCE policies and procedures.

STEP 3. Notify Distribution Automation Hotline if control power transformer is installed on the load side of the switch.

Figure 620P-15: Lineprobe Installation Distance Diagram

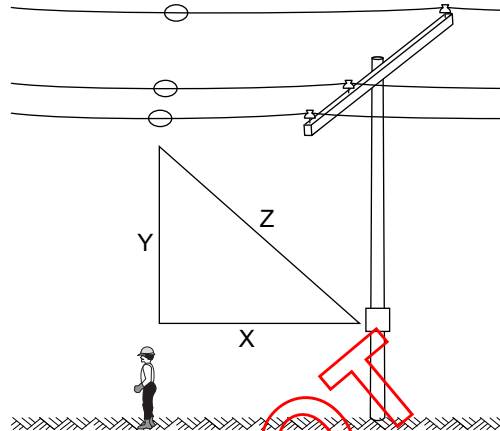

Table 620P-3: Lineprobe Distance to ADMO

Vertical (Y) Distance from Linescope Antenna to Lineprobe	Maximum Horizontal (X) Distance to Furthest Lineprobe ^{a/} (ft)
20	148
25	147
30	146
35	145
40	144
45	143
50	141
55	139
60	137
65	135
70	132
75	129
80	126
85	123
90	120

^{a/} These are maximum distances to the furthest probe. It is recommended for Lineprobe Sensors to be installed at the closest horizontal distance of 30 feet as measured from the face of the pole. Typical recommended maximum installation distance to furthest probe is 100 feet horizontal (X) from pole. Maximum distance "line of sight" (Z) to furthest probe is 150 feet.

- STEP 4. Starting with the Lineprobe labeled “Phase A”, connect the “Phase A” sensor ground conductor tail to the neutral wire. See, [Figure AP 620P–17](#), [Figure AP 620P–18](#), and [Figure AP 620P–19](#) for typical installation details. Measured from the lowest point of the sensor ground cable, construct with 4 foot MIN vertical clearance above underbuilt line conductors 0–16 kV; 4 foot MIN vertical clearance above SCE communication lines; and 6 foot MIN vertical clearance above non-SCE communication lines and antennas.
- STEP 5. With the Lineprobe labeled “Phase A”, clamp the Lineprobe’s ring and install the “Phase A” Lineprobe sensor on primary voltage line at installation point. Ensure the LINE side label of the sensor is installed facing the switch.



NOTE

Fully open the clamp before grasping it with the hot-line tool so that the clamp does not flop and become mis-aligned.

- STEP 6. Turn the ring clockwise to tighten the Lineprobe on the primary voltage line, until the Lineprobe makes contact with the line plus one-half turn. Belleville washers in a slip switch arrangement will ensure that proper clamping force is applied without risk of overtightening.
- STEP 7. Verify RF communication of the Lineprobe Phase A, by observing the flash behavior of the red RF LED on the RTU, indicating communication for each of the respective Lineprobe sensors. This LED shall flash once for each LineProbe that is configured. A long flash indicates good communication. A short flash indicates a radio communication problem.

Figure 620P–16: RF LED Communication indicator on lower left-hand corner of RTU

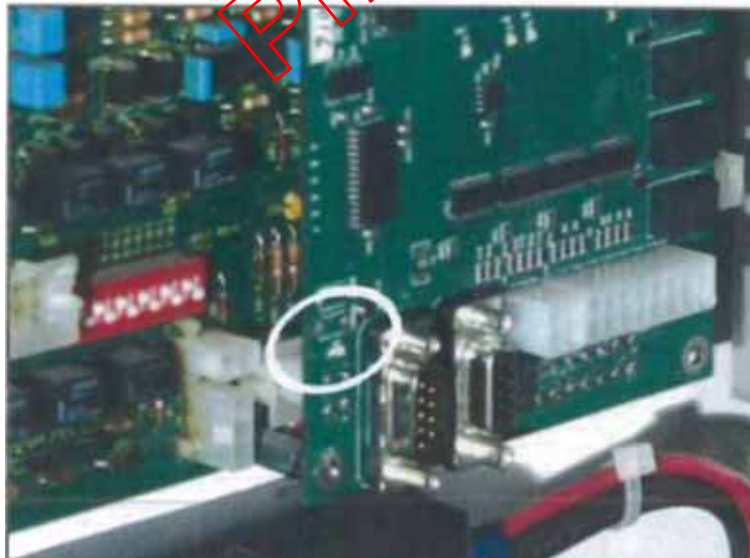

- STEP 8. Install the next Lineprobe sensor following Steps 1 through 7, for B then C phase.
- STEP 9. Perform End Point Test.

Approved by: <i>a/j</i>	Cleveland/Price Linescope Lineprobe Sensor for 12 kV and 16 kV 3-Phase 4-Wire Horizontal Construction Applications	AP 620P
Effective Date: 01-25-2019	What's Changed?	Sheet 17 of 19
		DOH

3.6 Installation of Linescope Lineprobe Sensors on Covered Conductor

- STEP 1. Covered Conductor shall be stripped 1-1/2 to 2 inches to install Lineprobe Sensor to make contact with conductor. See [CC 160](#) for Stripping Covered Conductor details.
- STEP 2. Hot Line Clamp on neutral must be covered. See [DC 535](#) for Wildlife Protection details.
- STEP 3. If Linescope Lineprobe is removed, stripped sections shall be covered. See [DC 535](#) for Wildlife Protection Details.

Use the following SAP codes for applicable conductor sizes:

- SAP 10200336 — 1/0 ACSR
- SAP 10180176 — 336.4 ACSR
- SAP 10180177 — 653.9 ACSR

Figure 620P-17: Typical Installation of CPI Linescope Lineprobe Sensor for 12 kV and 16 kV 3-Phase 4-Wire Horizontal Construction Applications

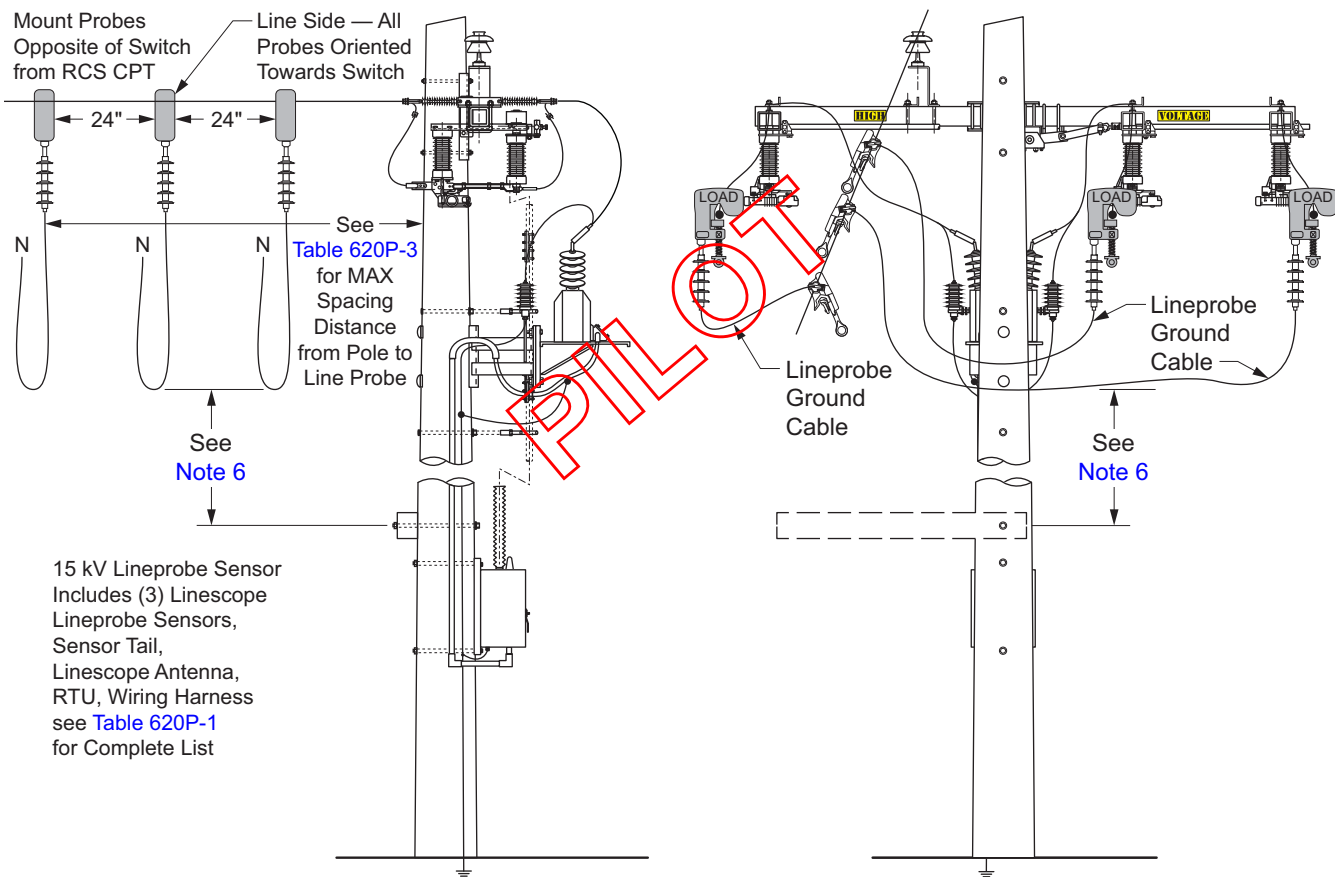

Note(s):

1. See [CO 300](#) and [CO 305](#) for Hot Line Clamp Details.
2. Per [DC 535](#), Wildlife Protection shall be constructed and installed as applicable for insulators, taps, leads, arrestors, cable terminations and equipment bushings.
3. Construction crew shall coordinate the installation of new and updated RCS with Distribution Automation Hotline in order to perform an end point test (EPT) and commission unit in service.

AP 620P

Sheet 18 of 19

DOH

Cleveland/Price Linescope Lineprobe Sensor for 12 kV and 16 kV 3-Phase 4-Wire Horizontal Construction Applications

What's Changed? Added section 3.6 for details on using Linescope Lineprobes with covered conductor.

Approved by:

ajf

Effective Date:

01-25-2019

4. Ensure the LINE side label of the sensor is installed facing the switch.
5. Maximum distance between switch crossarm and Lineprobe sensor shall be in accordance with [Table AP 620P-3](#).
6. Measured from the lowest point of the sensor ground cable, construct with 4 foot MIN vertical clearance above line conductors 0–16 kV; 4 foot MIN vertical clearance above SCE communication lines; and 6 foot MIN vertical clearance above non-SCE communication lines and antennas.
7. Verify minimum 24 inch clearance between sensor head and adjacent phase sensor head attachment.
8. Lineprobes are installed on opposite side of switch from control power transformer.

Figure 620P-18: Typical Installed Configuration of Lineprobes Using Hotline Clamps for Neutral



Figure 620P-19: Hotline Clamp per CO 300 and CO 305



Approved by: 	Cleveland/Price Linescope Lineprobe Sensor for 12 kV and 16 kV 3-Phase 4-Wire Horizontal Construction Applications	AP 620P
Effective Date: 01-25-2019	What's Changed?	Sheet 19 of 19 DOH

This page intentionally left blank.

DOH-CC: Covered Conductor

TABLE OF CONTENTS

<u>STANDARD</u>	<u>TITLE</u>
CC 100	Covered Conductor
CC 100.1	Covered Conductor General
CC 110	Cable Data
CC 110.1	15 kV Covered Conductors — 75°C Rated
CC 120	Sagging and Clearances
CC 120.1	Sagging Covered Conductors
CC 120.2	Directions for Use of Sag Charts
CC 120.3	Sag Chart and Clearances for 1/0 ACSR Covered Conductor
CC 120.4	Sag Charts and Clearances 336.4 ACSR Covered Conductor
CC 120.5	Sag Charts and Clearances 653.9 ACSR Covered Conductor
CC 120.6	Sag Charts and Clearances #2 Copper Covered Conductor
CC 121	Reduce Tension Span Sag Charts for Covered Conductors
CC 121.1	Directions for Use of Sag Charts
CC 121.2	Reduced Tension Sag Charts for Light-Loading Areas
CC 121.3	Reduced Tension Sag Charts for Heavy-Loading Areas
CC 130	Surge Arresters
CC 130.1	Application of Surge Arresters for Covered Conductors
CC 140	Neutrals in Covered Conductor Systems
CC 140.1	Covered Conductor Neutrals
CC 140.2	Establishing Neutral Grounds
CC 140.3	Covered Conductor Neutrals
CC 150	Covered Conductor Installation Materials and Equipment
CC 150.1	Covered Conductor Insulator
CC 150.2	Dead-Ending Covered Conductors
CC 170	Splicing Covered Conductors
CC 170.1	Compression Splices and Splice Covering Kit
CC 170.2	Cable Preparation, Splicing, and Installation of Splice Covering
CC 180	Transitioning to Bare Wire
CC 180.1	Transitioning from Covered Conductor to Bare Wire

Approved by: <i>ajf</i>	Covered Conductor Table of Contents	CC
Effective Date: 01-25-2019		Sheet 1 of 1
		DOH

This page intentionally left blank.

CC 100 Covered Conductor

Scope CC 100.1 Covered Conductor General

1.0 General

Covered Conductor (CC), also known as tree wire, is a conductor that is protected by layers of insulating material. There are four components in the covered conductor: the conductor, a conductor shield, an inner layer, and an outer layer.

The conductor can be Aluminum Conductor Steel-Reinforced (ACSR) or Hard Drawn Copper (HDCU). Copper covered conductor is for coastal applications due to copper being more resistant to corrosion than ACSR.

The conductor shield is made of a semi-conducting thermoset polymer. Its purpose is to reduce stress concentrations caused by flux lines from the individual conductor strands. By encircling the strands, it effectively transforms the strands into a single uniform conducting cylinder. The conductor shield can increase the life of the covered conductor by reducing the electrical stress on the contact area, therefore increasing the time to failure when an object makes contact with the covered conductor.

The inner layer is Crosslinked Low Density Polyethylene (XL-LDPE), which is an insulating material. The insulation contributes to the high impulse strength of the cover and protects the conductor from phase to phase and phase to ground contact.

The outer layer is Crosslinked High Density Polyethylene (XL-HDPE), which is an insulating material as well. It has the same insulating function as the inner layer. However, due to being high density, it is also a tougher layer, making it abrasion and impact resistant. The outer layer is also track resistant, which limits the charging current flowing on its surface. This track resistant property will help maintain the integrity of the insulation surface over time by significantly reducing electrical tracking that could lead to erosion of the insulation. Additionally, the XL-HDPE layer is specified for UV stability, making it less susceptible to UV degradation.

Covered conductor shall be treated and worked on as bare conductor and does not exempt tree trimming requirements.



NOTE

New installations of CC will have the XLPE layer as the outer layer. There will be some in-service 1/0 CC with the HDPE layer as the outer layer. The in-service 1/0 HDPE CC with a black covering is the 75°C rated covered conductor and will have a lower ampacity rating compared to new installations. The in-service 1/0 HDPE CC with a black stripe and gray covering is 90°C rated covered conductor and will have lower emergency and short circuit temperature ratings compared to the XLPE CC (see [Table CC 110-1](#) and [Table CC 110-2](#)).

Approved by: 	Covered Conductor	CC 100
Effective Date: 01-25-2019	What's Changed? Added new information on covered conductor regarding design and usage.	Sheet 1 of 2 DOH

Figure CC 100–1: Covered Conductor



Two covered conductor designs are available: A 17 kV designed covered conductor and a 35 kV designed covered conductor.

- 17 kV Covered Conductors may be used for a maximum of 17 kV, single- or three-phase circuits, laterals, or feeders. Neutral conductors are covered.
- 35 kV Covered Conductor may be used for a maximum of 35 kV, single- or three-phase circuits, laterals, or feeders. Neutral conductors are covered.

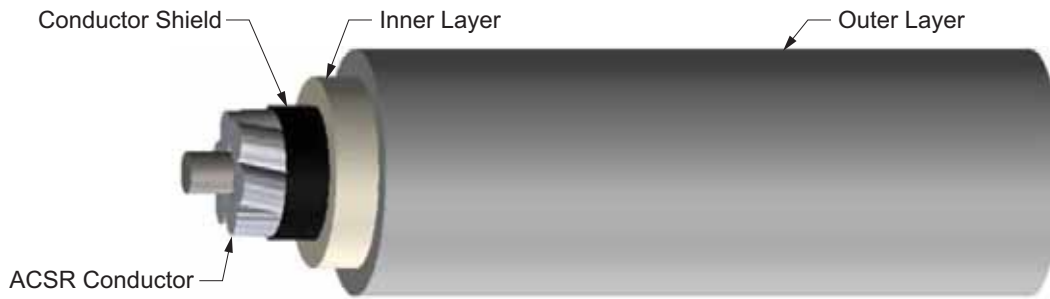
Installing Covered Conductor is the same as installing bare conductor except:

- Polymer Pin-Type Insulators with Vice-Top Nylon Inserts must be used
- Splices, dead-ends, equipment bushing, fuses, and lightning arresters must be covered
- Outer covering must be stripped before making any connections
- Surge Arresters must be installed with all overhead equipment and underground dips.

CC 100	Covered Conductor	Approved by: 
Sheet 2 of 2	What's Changed? Added new information on covered conductor regarding design and usage.	Effective Date:
DOH	Added new information on 35 kV rated covered conductor.	01-25-2019

CC 110 Cable Data

| Scope CC 110.1 15 kV Covered Conductors — 75°C Rated

Table CC 110–1: Cable Data — 75°C Rated ACSR Covered Conductor (Tree Wire)

SAP	Conductor Size (AWG)	Conductor Type	Cover Type	Weight (lb/ft)	Diameter (in)	Ampacity per Conductor ^{a/} (amps)
10110355	1/0	ACSR (6×1)	HDPE (150 mills)	0.262	0.698	202

^{a/} Covered Conductor Cable Normal Operating Rating Criteria:
 Ambient Temperature = 40°C
 Conductor Temperature = 75°C
 Load Factor = 100%
 Wind Speed = 4 ft/sec
 Coefficient of Emissivity = 0.91
 Coefficient of Absorption = 0.95
 Latitude = 34°
 Elevation of Conductor above Sea Level = 6,000 ft
 Atmosphere = Clear
 Local Sun Time = 1:00 pm

= For Reference Only

Approved by: <i>ajf</i>	Cable Data	CC 110
Effective Date: 01-25-2019	What's Changed?	Sheet 1 of 3
		DOH

Scope CC 110.2 17 kV Covered Conductors — 90°C Rated

Table CC 110–2: 17 kV Cable Data — 90°C Rated ACSR Covered Conductor (Tree Wire)

SAP	Conductor Size (AWG)	Conductor Type	Cover Type	Weight (lb/ft)	Conductor Diameter (in)	Overall Diameter (in)	Ampacity per Conductor ^{a/} (amps)
10211064	1/0	ACSR (6×1)	HDPE (165 mils)	0.284	0.398	0.728	271
10210583	1/0	ACSR (6×1)	XLPE (165 mils)	0.277	0.398	0.728	271
10210584	336.4	ACSR (18×1)	XLPE (165 mils)	0.564	0.684	1.014	550
10210585	653.9	ACSR (18×3)	XLPE (180 mils)	0.973	0.953	1.313	835

^{a/} Covered Conductor Cable Normal Operating Rating Criteria:

- Ambient Temperature = 40°C
- Conductor Temperature = 90°C
- Load Factor = 100%
- Wind Speed = 4 ft/sec
- Coefficient of Emissivity = 0.5
- Coefficient of Absorption = 0.5
- Latitude = 34°
- Elevation of Conductor above Sea Level = 0 ft
- Atmosphere = Clear
- Local Sun Time = 1:00 pm

= For Reference Only

Table CC 110–3: 17 kV Cable Data — 90°C Rated HDCU Covered Conductor (Tree Wire)

SAP	Conductor Size (AWG)	Conductor Type	Cover Type	Weight (lb/ft)	Conductor Diameter (in)	Overall Diameter (in)	Ampacity per Conductor ^{a/} (amps)
10211032	#2	HDCU (7)	XLPE (165 mils)	0.316	0.292	0.64	240
10211030	2/0	HDCU (7)	XLPE (165 mils)	0.569	0.414	0.783	367
10211031	4/0	HDCU (7)	XLPE (165 mils)	0.845	0.522	0.891	488

^{a/} Covered Conductor Cable Normal Operating Rating Criteria:

- Ambient Temperature = 40°C
- Conductor Temperature = 90°C
- Load Factor = 100%
- Wind Speed = 4 ft/sec
- Coefficient of Emissivity = 0.5
- Coefficient of Absorption = 0.5
- Latitude = 34°
- Elevation of Conductor above Sea Level = 0 ft
- Atmosphere = Clear
- Local Sun Time = 1:00 pm

CC 110

Sheet 2 of 3

DOH

Cable Data

What's Changed? Created separate scope for 17 kV rated Covered Conductor.

Approved by:

a/j

Effective Date:

01-25-2019

Scope CC 110.3 35 kV Covered Conductors — 90°C Rated

Table CC 110-4: 35 kV Cable Data — 90°C Rated ACSR Covered Conductor (Tree Wire)

SAP	Conductor Size (AWG)	Conductor Type	Cover Type	Weight (lb/ft)	Conductor Diameter (in)	Overall Diameter (in)	Ampacity per Conductor ^{a/} (amps)
10211784	1/0	ACSR (6×1)	XLPE (315 mils)	0.460	0.398	1.048	255
10211785	336.4	ACSR (18×1)	XLPE (315 mils)	0.850	0.684	1.333	518
10212033	336.4	ACSR (30×7)	XLPE (315 mils)	0.981	0.741	1.391	529
10211786	653.09	ACSR (18×3)	XLPE (320 mils)	1.242	0.952	1.603	784

^{a/} Covered Conductor Cable Normal Operating Rating Criteria:

- Ambient Temperature = 40°C
- Conductor Temperature = 90°C
- Load Factor = 100%
- Wind Speed = 4 ft/sec
- Coefficient of Emissivity = 0.5
- Coefficient of Absorption = 0.5
- Latitude = 34°
- Elevation of Conductor above Sea Level = 0 ft
- Atmosphere = Clear
- Local Sun Time = 1:00 pm

Approved by: <i>ajf</i>	Cable Data	CC 110
Effective Date: 01-25-2019	What's Changed? Added new cable data for 35 kV rated covered conductor.	
		DOH

This page intentionally left blank.

CC 120 Sagging and Clearances

Scope CC 120.1 Sagging Covered Conductors

Sag boards or dynamometers shall be used when sagging covered conductors. The use of sag boards or dynamometers will ensure that the covered conductor will be installed with the proper sag and tensions. It is important to ensure that proper sag and tensions are used in order to avoid vibration fatigue due to Aeolian vibration. Because the covering limits the movement of the conductor, covered conductors may be more susceptible to vibration fatigue if they are not sagged or tensioned properly.

See [Scope CO 100.1](#), [Section 1.0](#) for information on sagging.

Approved by: 	Sagging and Clearances	CC 120
Effective Date: 01-25-2019	What's Changed? Added new details regarding use of sag boards or dynamometers.	Sheet 1 of 8 DOH

Scope CC 120.2 Directions for Use of Sag Charts

See [CO 120](#) for directions for use of sag charts.



CAUTION

Do not use bare conductor sag values on covered conductor. It is important to follow the covered conductor sag charts. Lack of compliance may lead to failure.

CC 120	Sagging and Clearances	Approved by: 
Sheet 2 of 8	What's Changed?	Effective Date:
DOH		01-25-2019

Scope CC 120.3 Sag Chart and Clearances for 1/0 ACSR Covered Conductor

- | See [Scope CO 140.2](#) for Sag and Clearances for 17 kV and 35 kV 1/0 ACSR Covered Conductor for Light-Loading Areas
- | See [Scope CO 162.2](#) for Sag and Clearances for 17 kV and 35 kV 1/0 ACSR Covered Conductor for Heavy-Loading Areas

Approved by: 	Sagging and Clearances	CC 120
Effective Date: 01-25-2019	What's Changed?	Sheet 3 of 8 DOH

Scope CC 120.4 Sag Charts and Clearances 336.4 ACSR Covered Conductor

- | See [Scope CO 140.3](#) for Sag and Clearances for 17 kV and 35 kV 336.4 ACSR Covered Conductor for Light-Loading Areas
- | See [Scope CO 164.2](#) for Sag and Clearances for 17 kV and 35 kV 336.4 ACSR Covered Conductor for Heavy-Loading Areas

CC 120	Sagging and Clearances	Approved by: <i>ajf</i>
Sheet 4 of 8	What's Changed?	Effective Date: 01-25-2019
DOH		

Scope CC 120.5 Sag Charts and Clearances 653.9 ACSR Covered Conductor

- | See [Scope CO 142.2](#) for Sag and Clearances for 17 kV and 35 kV 653.9 ACSR Covered Conductor for Light-Loading Areas
- | See [Scope CO 166.2](#) for Sag and Clearances for 17 kV and 35 kV 653.9 ACSR Covered Conductor for Heavy-Loading Areas

Approved by: 	Sagging and Clearances	CC 120
Effective Date: 01-25-2019	What's Changed?	Sheet 5 of 8 DOH

Scope CC 120.6 Sag Charts and Clearances #2 Copper Covered Conductor

See [Scope CO 148.2](#) for Sag and Clearances for #2 Copper Covered Conductor for Light-Loading Areas.

See [Scope CO 152.2](#) for Sag and Clearances for #2 Copper Covered Conductor for Heavy-Loading Areas.

CC 120	Sagging and Clearances	Approved by: <i>ajf</i>
Sheet 6 of 8 DOH		What's Changed?

Scope CC 120.7 Sag Charts and Clearances 2/0 Copper Covered Conductor

See [Scope CO 148.3](#) for Sag and Clearances for 2/0 Copper Covered Conductor for Light-Loading Areas

See [Scope CO 160.2](#) for Sag and Clearances for 2/0 Copper Covered Conductor for Heavy-Loading Areas

Approved by: 	Sagging and Clearances	CC 120
Effective Date: 01-25-2019	What's Changed?	Sheet 7 of 8 DOH

Scope CC 120.8 Sag Charts and Clearances 4/0 Copper Covered Conductor

See [Scope CO 148.4](#) for Sag and Clearances for 4/0 Copper Covered Conductor for Light-Loading Areas

See [Scope CO 160.3](#) for Sag and Clearances for 4/0 Copper Covered Conductor for Heavy-Loading Areas

CC 120	Sagging and Clearances	Approved by: <i>a/j</i>
Sheet 8 of 8	What's Changed?	Effective Date: 01-25-2019
DOH		

CC 130 Surge Arresters

Scope CC 130.1 Application of Surge Arresters for Covered Conductors

For covered conductors, overvoltage events can lead to conductor or insulation damage if the overvoltage initiates an arc. In order to mitigate potential damage to the covered conductor surge arresters are to be applied to equipment and risers in accordance with existing standard requirements for High Lightning Density areas per [Subsection AP 400 5.2](#) and DDS-10 5.6.L.2, regardless of the lightning density at the installation location.

The specific equipment that must have arresters when installed in a covered conductor system are:

- Remote Automatic Reclosers (RARs)
- Remote Sectionalizing Reclosers (RSRs)
- Capacitors
- Line Voltage Regulators
- Power Transformers (PTs) associated with Remote Control Switches (RCSs)
- PTs associated with Overhead Preferred Emergency (PE) Equipment
- Overhead Transformers (All installations)

All underground dips from overhead lines must have arresters installed.

Approved by: <i>ajf</i>	Surge Arresters	CC 130
Effective Date: 01-25-2019	What's Changed? Added new information regarding what apparatus requires use of surge arresters in covered conductor systems.	Sheet 1 of 1 DOH

This page intentionally left blank.

CC 140 Neutrals in Covered Conductor Systems

Scope CC 140.1 Covered Conductor Neutrals

Use covered neutrals for covered conductor systems. The same nominal kV rated insulator can be used on all conductors provided that the neutral is identified with an “N” sign (SAP 10135124). If the same insulator is used on all conductors (A, B, C, and Neutral), the “N” sign shall be used on every crossarm to identify the neutral.

Figure CC 140–1: 4-Wire Construction with Neutral Identification

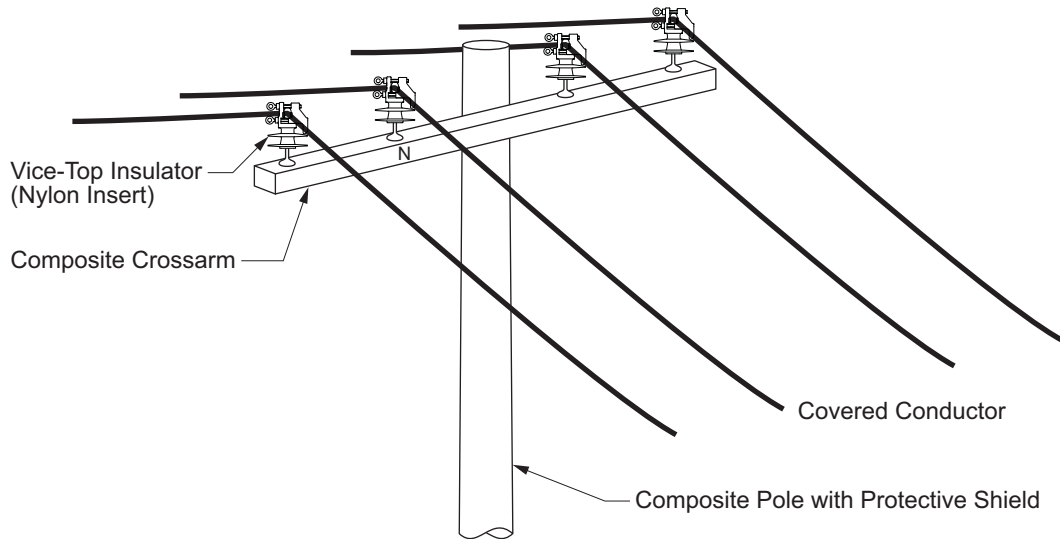

Refer to DDS-10 for grounding and neutral applications.

See [GR 110](#) for establishing neutral grounds in a 4-wire system.

Approved by: 	Neutrals in Covered Conductor Systems	CC 140
Effective Date: 01-25-2019	What's Changed? Removed grounding information. Added new figure depicting placement of “N” sign in covered conductor system.	Sheet 1 of 1 DOH

This page intentionally left blank.

CC 150 Covered Conductor Installation Materials and Equipment

Scope CC 150.1 Covered Conductor Insulator

Vice-Top Polymer Pin-Type Line Insulators with Nylon Inserts are required for use with covered conductors. If covered conductors use equipment that has a different material than the covering, such as porcelain insulators or metallic inserts, the voltage gradient will cause tracking on the covering due to dielectric incompatibility. Tracking will erode the covering over time. To prevent damage on the covered conductor, polymer insulators and nylon inserts shall be used.

Do not strip the covering when installing the covered conductor on the insulator.

See [Scope GR 200.5](#) for Polymer Pin-Type Line Insulators — Vice-Top, Nylon Inserts applications.

Figure CC 150–1: Covered Conductor on Vice-Top, Nylon Insert Insulator

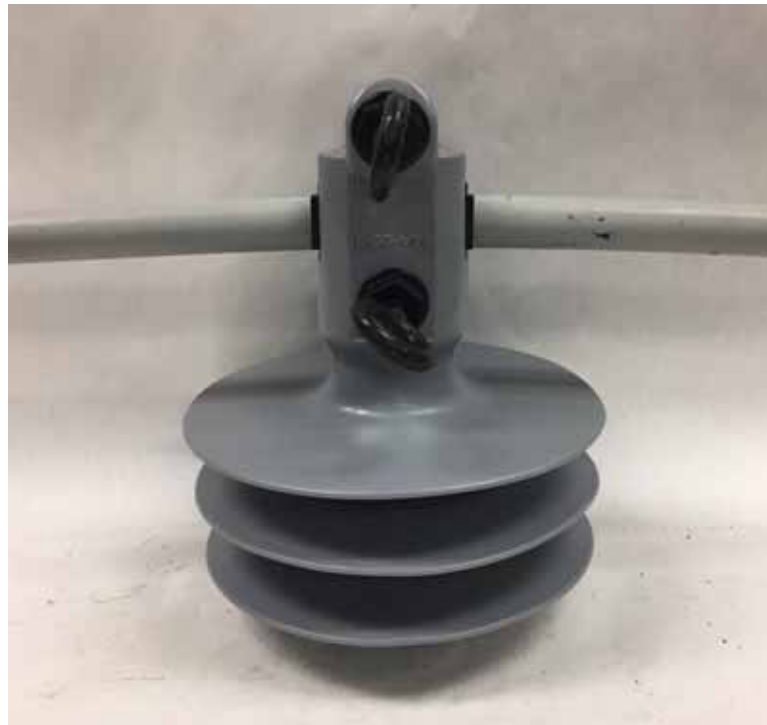

Approved by: 	Covered Conductor Installation Materials and Equipment	CC 150
Effective Date: 01-25-2019	What's Changed? Added new details for use of polymer vice-top, nylon insert insulators.	Sheet 1 of 2 DOH

Scope CC 150.2 Dead-Ending Covered Conductors

See [CO 200](#) and [CO 201](#) for dead-ending tables for wood crossarms and composite crossarms, respectively.

See [CO 207](#) for dead-ending covered conductors.

See [CO 211](#) and [CO 212](#) for dead-ending wood crossarm and composite crossarm construction, respectively.

Dead-ends shall be covered with a Dead End Clamp in covered conductor systems. Covering dead-ends will ensure that stripped portions of the covered conductor at the dead-end will be protected from contact that could lead to phase-to-phase or phase-to-ground faults (see [Table DC 535-1](#) for the Dead End Clamp).

Figure CC 150-2: 4-Wire Covered Conductor Dead-end Construction

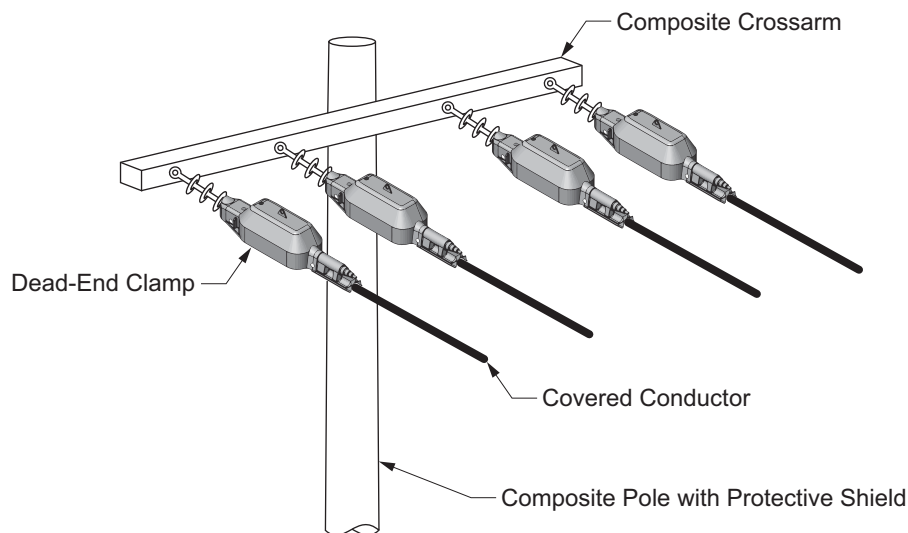

CC 170 Splicing Covered Conductors

Scope CC 170.1 Compression Splices and Splice Covering Kit

1.0 Aluminum Splices and Splice Covering Kit

1.1 Application

To be used on aluminum conductors of distribution voltages 17 kV and below.

Splices on Covered Conductors must be covered. See [Table CC 170–2](#) for appropriate splice covering kit.

Table CC 170–1: ACSR Covered Conductor Full and Partial Tension Splices

Wire Size	Splice SAP	MD-6 Die No. & SAP	Y34A Die No. & SAP	Y35-Y39-12HA Die No. & SAP	UT-15 Die No. & SAP	Number of Crimps per End
1/0-AWG (6/1)	10112092	W-702 SAP 10148865	N/A	U-247 SAP 10148910	See Note 1	MD6=14 Others=7
336.4 kcmil (18/1)	10112095	N/A	N/A	U-655 SAP 10148913	See Note 1	Overlap
336.4 kcmil (30/7)	10112041	N/A	N/A	B20AH-14AH SAP 10148918 B10SH SAP 10145917	See Note 1	Overlap
653.9 kcmil (18/3)	10112096 See Note 2	N/A	N/A	N/A	15C140R SAP 10148896	6

Note(s):

1. Use adapter die SAP 10148852 to fit Y35, Y39, or 12HA dies in UT-15 tool.
2. Partial Tension Splice, 93 percent rated breaking strength (RBS), or 13,800 lb.

Table CC 170–2: 17 kV Aluminum Splice Covering Kit

SAP	Conductor Size (AWG)	Conductor Type	Splice Tube Length (in)
10211073	1/0	ACSR	30
10211073	336.4	ACSR	30
10211075	653.9	ACSR	36

Table CC 170–3: 35 kV Aluminum Splice Covering Kit

SAP	Conductor Size (AWG)	Conductor Type	Splice Tube Length (in)
10212076	1/0	ACSR	30
10212076	336.4 (18×1)	ACSR	30
10212077	336.4 (30×7)	ACSR	36
10212077	653.9	ACSR	36

2.0 Copper Splices and Splice Covering Kit

2.1 Application

To be used on copper covered conductors of distribution voltages 17 kV and below. Splices on covered conductors must be covered. See Table CC 170-3 for appropriate splice covering kit.

See Table CO 410-1 for appropriate splices and applicable tools and die for the copper covered conductors.

Table CC 170–4: Copper Splice Covering Kit

SAP	Conductor Size (AWG)	Conductor Type	Splice Tube Length (in)
10211072	#2	HDCU	22
10211072	2/0	HDCU	22
10211072	4/0	HDCU	22

CC 170

Splicing Covered Conductors

Approved by:

a/j

Sheet 2 of 5

What's Changed? Table number updated.

Effective Date:

DOH

01-25-2019

Scope CC 170.2 Cable Preparation, Splicing, and Installation of Splice Covering

1.0 Cable Preparation and Splicing

Covered Conductors are spliced and tapped at in the same manner as bare wire, except the conductor must be stripped first. Splices must be covered in a covered conductor system.

- 1.1 Remove the conductor covering, including the conductor shield using an approved stripping tool. The length of conductor stripped on each side should be half the length of the splice plus Dimension "A" (see Table CC 170-5) on each end (see Figure CC 170-2).



Care should be taken to ensure that the conductor strands are not nicked or damaged.

Figure CC 170-1: Compression Splice

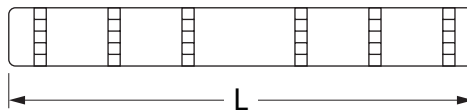

Figure CC 170-2: Cable Preparation

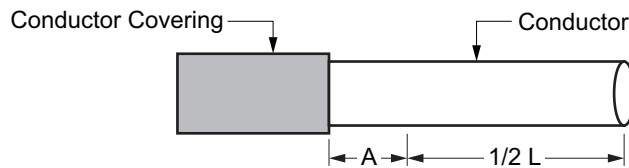

Table CC 170-5: Cable Prep Dimension "A"

Conductor (AWG)	Conductor Type	Dimension "A" (in)
1/0	ACSR	0.75
336.4 (18/1)	ACSR	0.75
653.9	ACSR	3.5
#2	HDCU	0.75
2/0	HDCU	0.75
4/0	HDCU	0.75

Approved by:

ajf

Splicing Covered Conductors

CC 170

Effective Date:
01-25-2019

What's Changed?

Sheet 3 of 5

DOH

- 1.2 Clean the outer surface of the cable covering for a length of 10-inches on each side using the cleaning pad provided in the kit. After cleaning, wipe surfaces dry with clean cloth.
- 1.3 Slip the cold shrink tube over one of the cable ends and push back far enough to be out of the way during the crimping and taping process.

Figure CC 170-3: Cold Shrink Tube

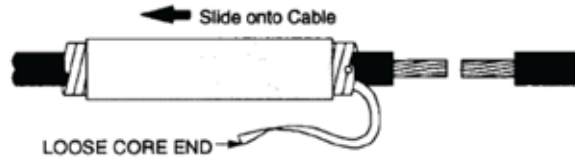

- 1.4 Using a marking tape, mark the conductor covering "B" inches back from the conductor end on both sides (see Figure CC 170-4).

Figure CC 170-4: Marker Tape

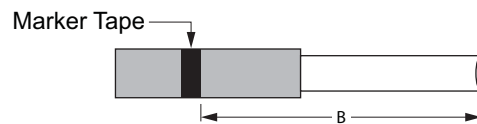
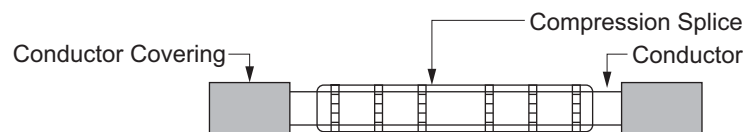

Table CC 170-6: Cable Prep Dimension "B"

Conductor (AWG)	Conductor Type	Dimension "B" (in)
1/0	ACSR	15
336.4 (18/1)	ACSR	15
653.9	ACSR	18
#2	HDCU	11
2/0	HDCU	11
4/0	HDCU	11

- 1.5 Slide ends of conductor all the way into the connector body and crimp using Table CC 170-1 as a reference for the number of crimps and the tool and die set. Keep connector as straight as possible.



2.0 Installation of Splice Covering

- 2.1 Install each of the two provided mastic strips on each end of the splice between the end of the splice body and the cable covering to fill this space. Stretch the mastic just to fill the space without overlapping the splice body or conductor covering. Use all the mastic provided.

Figure CC 170–5: Mastic Application

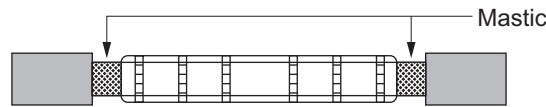

2.2 Semi-conducting Tape

Beginning 1/2 inch over the cable insulation, apply a half-lapped layer of Semi-Conducting Tape across the connector to 1/2 inch over the insulation on the other side of the splice.

Figure CC 170–6: Semi-Conducting Tape

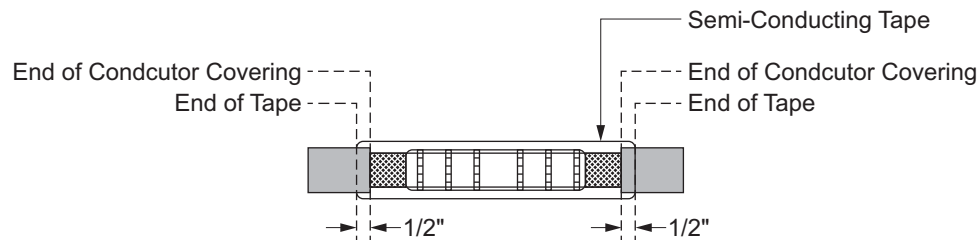

- 2.3 Position cold shrink splice tube over connection. Align leading edge of rubber (not core) with the mark. Remove core ribbon slowly by pulling, while unwinding the loose core ribbon end in a counter-clockwise direction

Figure CC 170–7: Cold Shrink Application



Note(s):

- Splices for adjacent conductors should not be installed next to each other. Splices should be staggered by at least 18 inches end to end.
- Conductor Splices should not be installed closer than 5 feet from a corner structure. Ensure that all tree limbs and branches are trimmed away from the area of the conductor splices. Tree limb contact on splice covering should be avoided.

Approved by: <i>ajf</i>	Splicing Covered Conductors	CC 170
Effective Date: 01-25-2019	What's Changed?	Sheet 5 of 5
		DOH

This page intentionally left blank.

CC 180 Transitioning to Bare Wire

Scope CC 180.1 Transitioning from Covered Conductor to Bare Wire

Covered Conductors must be dead-ended at a dead-end pole when transitioning to bare wire. Splices are not to be used when transitioning from a covered conductor system to bare wire system.

Figure CC 180-1: Covered Conductor to Bare Wire Transition

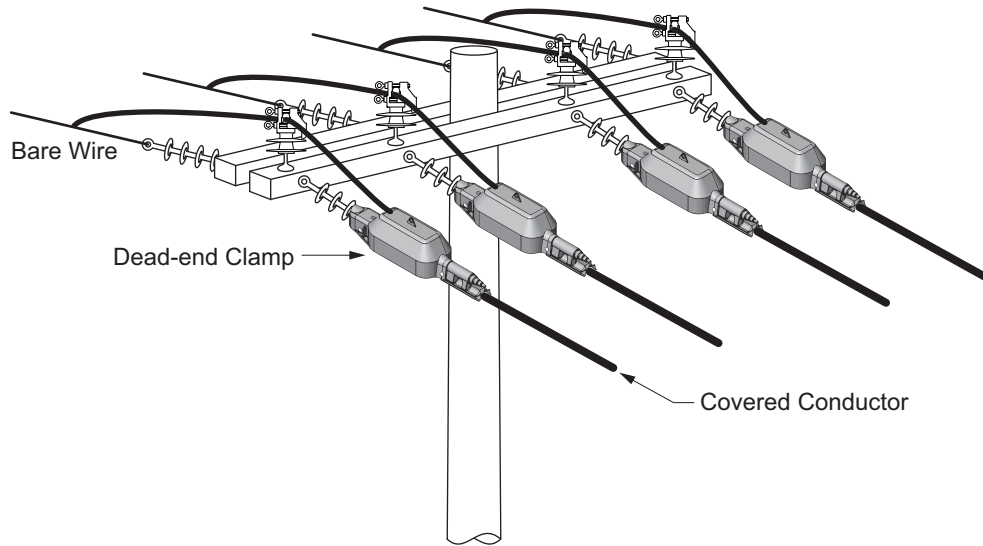

Approved by: 	Transitioning to Bare Wire	CC 180
Effective Date: 01-25-2019	What's Changed? Added new figure depicting transition from covered conductor system to bare wire.	Sheet 1 of 1 DOH

This page intentionally left blank.

DOH-CO: Conductors and Splices

TABLE OF CONTENTS

<u>STANDARD</u>	<u>TITLE</u>
CO 100	Installation of Conductors and Connectors
CO 100.1	Installation of Conductors and Connectors
CO 104	Distribution Conductors General Information
CO 104.1	General Information for Copper and Aluminum Overhead Conductors
CO 106	Characteristics of Overhead Aluminum Conductor
CO 106.1	Overhead Aluminum Conductor Physical and Electrical Properties
CO 106.2	Overhead Copper Conductor Physical and Electrical Properties
CO 107	Curves for Short-Time Loadability
CO 107.1	Short-Time Loadability for ACSR Conductors
CO 107.2	Short-Time Loadability for Copper Conductors
CO 108	Triplex/Quadruplex Secondary — General Requirements
CO 108.1	General Information for Installation of Triplex and Quadruplex Secondary Conductors
CO 109	Minimum Size Wire to X-Ray Services
CO 109.1	Minimum Size Wire to X-Ray Services
CO 110	Stringing Tensions — Table
CO 110.1	ACSR and Copper Stringing Tensions
CO 120	Sag Charts — Directions for Use
CO 120.1	Directions for Use of Sag Charts
CO 132	Sag Chart #4 Aluminum Duplex ACSR Messenger
CO 132	Sag Chart #4 Aluminum Duplex ACSR Messenger
CO 134	Sag Charts #4 and #2 Aluminum Triplex
CO 134.1	Sag — Temperature Stringing Table #4 and #2 Aluminum Triplex for Light-Loading Areas
CO 136	Sag Charts 1/0 and 4/0 Aluminum Triplex
CO 136.1	Sag — Temperature Stringing Table 1/0 and 4/0 Aluminum Triplex for Light-Loading Areas
CO 138	Sag Charts 1/0 and 4/0 Aluminum Quadruplex
CO 138.1	Sag — Temperature Stringing Table 1/0 and 4/0 Aluminum Quadruplex for Light-Loading Areas
CO 140	Sag Chart #4—336 ACSR
CO 140.1	Sag — Temperature Stringing Table #4 — 336 ACSR for Light-Loading Areas
CO 142	Sag Chart 653 ACSR
CO 142.1	Sag — Temperature Stringing Table 653 ACSR for Light-Loading Areas
CO 142.2	Sag — Temperature Stringing Table 653 ACSR Covered Conductor for Light-Loading Areas
CO 146	Sag Chart #8 Copper Duplex
CO 146.1	Sag — Temperature Stringing Table #8 M.H.D. Copper Wire Duplex with Polyethylene Insulation for Light-Loading Areas

Approved by: <i>ajf</i>	Conductors and Splices Table of Contents	CO
Effective Date: 01-25-2019		Sheet 1 of 5
		DOH

STANDARD	TITLE
CO 148	Sag Chart #6 — 4/0 Copper
CO 148.1	Sag — Temperature Stringing Table #6 — 4/0 Copper for Light Loading Areas
CO 148.2	Sag — Temperature Stringing Table #2 Copper Covered Conductor for Light-Loading Areas
CO 148.3	Sag — Temperature Stringing Table 2/0 Copper Covered Conductor for Light-Loading Areas
CO 148.4	Sag — Temperature Stringing Table 4/0 Copper Covered Conductor for Light-Loading Areas
CO 150	Sag Chart #4 Copper and #4 ACSR
CO 150.1	Sag — Temperature Stringing Table #4 Copper and #4 ACSR for Heavy-Loading Areas
CO 152	Sag Chart #2 Copper
CO 152.1	Sag — Temperature Stringing Table #2 Copper for Heavy-Loading Areas
CO 154	Sag Chart #4 Aluminum Duplex
CO 154.1	Sag — Temperature Stringing Table Streetlight Secondary 120 V #4 Aluminum Duplex for Heavy-Loading Areas
CO 155	Sag Charts #4 and #2 Aluminum Triplex
CO 155.1	Sag — Temperature Stringing Table #4 and #2 Aluminum Triplex for Heavy-Loading Areas
CO 156	Sag Charts 1/0 and 4/0 Triplex
CO 156.1	Sag — Temperature Stringing Table 1/0 and 4/0 Triplex for Heavy-Loading Areas
CO 158	Sag Charts 1/0 and 4/0 Quadruplex
CO 158.1	Sag — Temperature Stringing Table 1/0 and 4/0 Quadruplex for Heavy-Loading Areas
CO 160	Sag Chart 2/0 and 4/0 Copper
CO 160.1	Sag — Temperature Stringing Table 2/0 and 4/0 Copper for Heavy-Loading Areas
CO 162	Sag Chart 1/0 ACSR
CO 162.1	Sag — Temperature Stringing Table 1/0 ACSR for Heavy-Loading Areas
CO 164	Sag Chart 336 ACSR
CO 164.1	Sag — Temperature Stringing Area 336 ACSR for Heavy-Loading Areas
CO 166	Sag Chart 654 ACSR
CO 166.1	Sag — Temperature Stringing Table 654 ACSR for Heavy-Loading Areas
CO 168	Reduce Tension Span Sag Charts — Directions for Use
CO 168.1	Directions for Use of Sag Charts
CO 168.2	Sag Chart for New and Existing Reduced Tension Guyed Primary #4 — 653 ACSR for Light-Loading Areas
CO 168.3	Sag Chart for New and Existing Reduced Tension Guyed Primary 1/0 — 653 ACSR Covered Conductor for Light-Loading Areas
CO 168.4	Sag Chart for New and Existing Reduced Tension Guyed Primary #6 — 4/0 Copper for Light-Loading Areas
CO 168.5	Sag Chart for New and Existing Reduced Tension Guyed Primary #2 — 4/0 Copper Covered Conductor for Light Loading Areas
CO 168.6	Sag Chart for New and Existing Reduced Tension Guyed #6 — 1/0 Aluminum Duplex and Triplex for Light-Loading Areas

<u>STANDARD</u>	<u>TITLE</u>
CO 168.7	Sag Chart for New and Existing Reduced Tension Guyed #4 — 4/0 Aluminum Quadruplex for Light-Loading Areas
CO 168.8	Sag Chart for New Reduced Tension Unguyed #4 — 653 ACSR for Light-Loading Areas
CO 168.9	Sag Chart for New Reduced Tension Unguyed 1/0 — 653 ACSR Covered Conductor for Light-Loading Areas
CO 168.10	Sag Chart for New Reduced Tension Unguyed #6 — 4/0 Copper for Light-Loading Areas
CO 168.11	Sag Chart for New Reduced Tension Unguyed #2 — 4/0 Copper Covered Conductor for Light-Loading Areas
CO 168.12	Sag Chart for New Reduced Tension Unguyed #6 — 1/0 Aluminum Duplex and Triplex for Light-Loading Areas
CO 168.13	Sag Chart for New Reduced Tension Unguyed #4 — 4/0 Aluminum Quadruplex for Light-Loading Areas
CO 168.14	Sag Chart for Existing and Rebuild Reduced Tension Unguyed #4 — 653 ACSR for Light-Loading Areas
CO 168.15	Sag Chart for Existing and Rebuild Reduced Tension Unguyed 1/0 — 653 ACSR Covered Conductor for Light-Loading Areas
CO 168.16	Sag Chart for Existing and Rebuild Reduced Tension Unguyed #6 — 4/0 Copper for Light-Loading Areas
CO 168.17	Sag Chart for Existing and Rebuild Reduced Tension Unguyed #2 — 4/0 Copper Covered Conductor for Light-Loading Areas
CO 168.18	Sag Chart for Existing and Rebuild Reduced Tension Unguyed #6 — 4/0 Aluminum Duplex and Triplex for Light-Loading Areas
CO 168.19	Sag Chart for New and Existing Reduced Tension Guyed #4 — 653 ACSR for Heavy-Loading Areas
CO 168.20	Sag Chart for New and Existing Reduced Tension Guyed 1/0— 653 ACSR Covered Conductor for Heavy-Loading Areas
CO 168.21	Sag Chart for New and Existing Reduced Tension Guyed #6 — 4/0 Copper for Heavy-Loading Areas
CO 168.22	Sag Chart for New and Existing Reduced Tension Guyed #2 — 4/0 Copper Covered Conductor for Heavy-Loading Areas
CO 168.23	Sag Chart for New and Existing Reduced Tension Guyed #6 — 1/0 Aluminum Duplex and Triplex for Heavy-Loading Areas
CO 168.24	Sag Chart for New and Existing Reduced Tension Guyed #4 — 4/0 Aluminum Quadruplex for Heavy-Loading Area
CO 168.25	Sag Chart for New Reduced Tension Unguyed #4 — 653 ACSR for Heavy-Loading Areas
CO 168.26	Sag Chart for New Reduced Tension Unguyed 1/0 — 653 ACSR Covered Conductor for Heavy-Loading Areas
CO 168.27	Sag Chart for New Reduced Tension Unguyed #6 — 4/0 Copper for Heavy-Loading Areas
CO 168.28	Sag Chart for New Reduced Tension Unguyed #2 — 4/0 Copper Covered Conductor for Heavy-Loading Areas
CO 168.29	Sag Chart for New Reduced Tension Unguyed #6 — 1/0 Aluminum Duplex and Triplex for Heavy-Loading Areas

Approved by: <i>ajf</i>	Conductors and Splices Table of Contents	CO
Effective Date: 01-25-2019		Sheet 3 of 5
		DOH

STANDARD	TITLE
CO 168.30	Sag Chart for New Reduced Tension Unguyed #4 — 4/0 Aluminum Quadruplex for Heavy-Loading Areas
CO 168.31	Sag Chart for Existing and Rebuild Reduced Tension Unguyed #4 — 653 ACSR for Heavy-Loading Areas
CO 168.32	Sag Chart for Existing and Rebuild Reduced Tension Unguyed 1/0 — 653 ACSR Covered Conductor for Heavy-Loading Areas
CO 168.33	Sag Chart for Existing and Rebuild Reduced Tension Unguyed #6 — 4/0 Copper for Heavy-Loading Areas
CO 168.34	Sag Chart for Existing and Rebuild Reduced Tension Unguyed #2 — 4/0 Copper Covered Conductor for Heavy-Loading Areas
CO 168.35	Sag Chart for Existing and Rebuild Reduced Tension Unguyed #6 — 4/0 Aluminum Duplex and Triplex for Heavy-Loading Areas
CO 200	Dead-Ending Tables
CO 200.1	Crossarm Requirements for Dead-Ending All Sizes of Copper and ACSR Conductors
CO 201	Composite Arm Dead-Ending Tables
CO 201.1	Composite Crossarm Requirements for Dead-Ending All Sizes of Copper and ACSR Conductors
CO 205	Dead-Ending — All Aluminum and ACSR
CO 205.1	Dead-Ending Method for All Aluminum and ACSR Conductors
CO 207	Dead-Ending — Aluminum and Copper
CO 207.1	Dead-Ending Methods
CO 207.2	Automatic Wedge Straight Line Clamp
CO 209	Dead-Ending — ACSR and Copper
CO 209.1	Typical Dead-Ending Methods to Prevent Radio Interference
CO 211	Dead-Ending — Wood Crossarm Construction
CO 211.1	Wood Crossarm Construction Requirements for Dead-Ending Conductors
CO 212	Dead-Ending — Composite Crossarm Construction
CO 212.1	Composite Crossarm Construction Requirements for Dead-Ending Conductors
CO 215	Dead-Ending — Copper Conductors
CO 215.1	Typical Dead-Ending for Copper Conductors
CO 217	Dead-ending Method—Sectionalizer Links (Isolators)
CO 217.1	Typical Construction for Sectionalizer Links/Isolators
CO 300	Copper-to-Copper Connectors
CO 300.1	Copper-to-Copper Connectors
CO 305	Connectors — Copper-to-Aluminum and Aluminum-to-Aluminum
CO 305.1	Connectors — Copper-to-Aluminum and Aluminum-to-Aluminum
CO 400	Splices — Full Tension — Copper #8 — 250 kcmil
CO 400.1	Full Tension Splice Information for Copper #8 — 250 kcmil Automatic Splices
CO 400.2	Full Tension Splice Information for #4 — 336.4 ACSR Automatic Splice

STANDARD **TITLE**

CO 410	Compression Splices
CO 410.1	Tool and Die List for Full Tension Compression Splices
CO 410.2	Tool and Die List for Full and Partial Tension Compression Splices
CO 410.3	Instructions for Installing Full Tension, Double-Sleeve, Compression Splices for ACSR Conductors
CO 410.4	ACSR Repair Splice for #4, 1/0, and 336.4 ACSR
CO 420	Bolted Wedge Connector
CO 420.1	ACSR - ACSR, ACSR - CU and CU - CU Bolted Wedge Connectors
CO 450	Insulated Overhead Wire Spacers
CO 450.1	Insulated Overhead Wire Spacers for 4 kV, 12 kV, 16 kV, and 34.5 kV Systems
CO 460	Installation Procedures for Spiral Vibration Dampers
CO 460.1	Installation Procedures for Spiral Vibration Dampers
CO 470	ClampStar [®] Splice Shunt
CO 470.1	Installation Procedures for ClampStar [®] Splice Shunt
CO 500	Insulator Ties Copper and Aluminum
CO 500.1	Wire Length and Method of Securing the Conductor to the Insulator
CO 500.2	Insulator Ties Copper and Aluminum
CO 505	Insulator Ties Using Weather-Resistant Copper Conductor 0–5 kV
CO 505.1	Typical Insulator Ties Using Weather-Resistant Copper Conductor 0–5 kV
CO 510	Insulator Conductor Clamps
CO 510.1	Applications and SAP Numbers for Insulator Conductor Clamps
CO 515	Universal Conductor Clamps — Angle Pins
CO 515.1	Typical Universal Conductor Clamps — Angle Pins
CO 520	Grip-Type Conductor Clamps
CO 520.1	Typical Grip-Type Conductor Clamps
CO 600	Terminating Large Copper and Aluminum Services
CO 600.1	Method of Dead-Ending All-Aluminum and Copper Conductors
CO 700	Span Lengths, Minimum Conductor Spacing, Composite and Wood Crossarm Pre-Drilled Holes
CO 700.1	Span Lengths and Minimum Conductor Spacing
CO 700.2	Composite Crossarm Pre-Drilled Holes
CO 700.3	8' and 10' Composite Crossarm Mounting Bracket Details
CO 700.4	12' and 20' Composite Crossarm Mounting Bracket Details
CO 700.5	Wood Crossarm Pre-Drilled Holes

Approved by: <i>ajf</i>	Conductors and Splices Table of Contents	CO
Effective Date: 01-25-2019		Sheet 5 of 5
		DOH

This page intentionally left blank.

CO 104 Distribution Conductors General Information

Scope CO 104.1 General Information for Copper and Aluminum Overhead Conductors

1.0 Standard Sizes

The following sizes of bare and covered copper and aluminum conductors are in general use by the Company for overhead distribution lines.

Due to the corrosive environment in the beach areas within ONE MILE of the ocean, only bare or copper covered conductor sizes 2/0 and smaller, greased or covered ACSR conductor sizes 336.4 and larger should be used for overhead construction. Any specific area that experiences accelerated corrosion because of unique circumstances should contact Field Engineering for review.

1.1 Copper

A. Hard drawn, bare — Material Standard Specification No. 7

1. #6 and #4 solid
2. #4, #2, 2/0, and 4/0 stranded

B. THW Moisture Resistant

1. Soft drawn, #8 solid
2. Soft drawn, #6, #4, and #2 stranded
3. Soft drawn, 2/0 and 4/0 stranded

C. Triplex — Material Standard Specification No. 233

1. #6, #4, and #2

1.2 Aluminum

A. ACSR - Material Standard Specification No. 232

1. #4, 1/0, 336.4 kcmil, and 653.9 kcmil stranded

B. Weather-Resisting - Material Standard Specification No. 234, FOR REFERENCE ONLY

1. #6 solid
2. #2, 1/0, 4/0, 500 kcmil, and 750 kcmil stranded

Approved by: <i>ajf</i>	Distribution Conductors General Information	CO 104
Effective Date: 01-25-2019	What's Changed? Minor edit to Section 1.0 to include the use of bare of covered conductor in areas within one mile of the ocean.	Sheet 1 of 3 DOH

C. Multiplex - Material Standard Specification No. 233

1. Duplex: #6 and #4 stranded
2. Triplex: #4, #2, 1/0, and 4/0 stranded
3. Quadruplex: #4, 1/0, and 4/0 stranded

D. CLP Insulated Cable - Material Standard Specification No. 238

1. 3-1/C: (2-#2, 1-#4); (2-1/0, 1-#2); (2-4/0, 1-1/0); (2-350, 1-4/0); (2-700, 1-350)
2. 4-1/C: (3-1/0, 1-#2); (3-4/0, 1-1/0); (3-350 kcmil, 1-4/0); (3-700 kcmil, 1-350 kcmil)

2.0 Determination of Conductor Size

In order to determine the proper size of conductor to use, the following factors should be known:

1. Line voltage and number of phases
2. Total load to be supplied (including future)
3. Power factor of load
4. Length of line
5. Configuration and spacing of conductors
6. Permissible voltage drop

The proper size of conductor is determined by consideration of the above factors and also the “economic” loading of the conductors. The conductor must be capable of carrying presently-known load currents without excessive voltage drop. Just as important, the conductor should be capable of carrying the anticipated future loads. The recommended conductor size for the best “economic” loading is given in the Distribution Design Standards (DDS-2).

Bare wire shall be used on Primary Voltage circuits wherever practical. Covered wire should normally be used on secondary voltage circuits.

Bare and covered aluminum and copper wire shall not be installed adjacent to each other on the same end of a crossarm, but bare wire may be used on one end of the arm, and covered wire on the other end where the two classifications are separated by 30 inches. The minimum spacing for bare wire is 20 inches for spans up to 205 feet. (Exception: Spacing of less than 20 inches may be used in special cases.)

Note: Where copper and aluminum conductors are used on the same circuit, existing voltage drop tables do not apply.

CO 104	Distribution Conductors General Information	Approved by: <i>ajf</i>
	Sheet 2 of 3	Effective Date: 01-25-2019
DOH	What's Changed?	

3.0 Tie Wires

3.1 Aluminum

- A. #4 through 336.4 kcmil ACSR aluminum conductors shall be protected by aluminum armor rod where the conductor is attached to pin or post-type insulators. Aluminum conductors shall be tied to insulators with special aluminum tie wire as shown in the [CO Section](#).

Note: On ACSR conductor sizes #4 through 336.4 kcmil #4 aluminum tie wire shall be used.

- B. 653.9 kcmil ACSR conductor shall be clamped to post-type insulators as shown in the [CO Section](#), without armor rod.

Note: Exception: Where Universal Clamps and Covered Conductors are used.

3.2 Bare Copper Wire Solid or Stranded

- A. On all bare copper conductors, solid or stranded, the tie wires shall be soft drawn copper wire purchased specifically for this purpose. The size and strength of the tie wire shall be #6 AWG soft drawn copper for conductor sizes #6 and #4, and #4 AWG soft drawn copper for conductor sizes #2 AWG and larger.
- B. On High Voltage distribution lines, of over 5000 V phase-to-phase, conductors shall be tied to the insulators as shown in the [CO Section](#). (See Index.)
- C. On distribution lines of 5000 V or less phase-to-phase, conductors shall be tied to the insulators as shown in the [CO Section](#).

Approved by: 	Distribution Conductors General Information	CO 104
Effective Date: 01-25-2019	What's Changed?	Sheet 3 of 3 DOH

This page intentionally left blank.

CO 108 Triplex/Quadruplex Secondary — General Requirements

Scope CO 108.1 General Information for Installation of Triplex and Quadruplex Secondary Conductors

1.0 Conductor

- 1.1 Secondary conductors are sized based on customer demand, voltage drop, flicker, and motor starting load. Refer to sag charts for stringing conductor.
- 1.2 Use of copper triplex (squirrel wire) shall be considered in areas experiencing reoccurring secondary/service drop replacements due to rodent damage (chewing). In areas where high vegetation and rodent population exists, preventative measures like using copper secondary conductors shall be employed. Similarly, conductors should be sized based on customer demand, voltage drop, flicker, and motor starting load. See [Table CO 106–5](#) for copper secondary and service drop data. Refer to sag charts for stringing conductor.

2.0 Load

- 2.1 Care must be taken not to exceed the safe current carrying capacity of Triplex (190 A for 1/0 Al).
- 2.2 Excessive current can cause the insulation of the phase wires to heat and flow resulting in a reduced insulation level between phase and neutral conductors.

3.0 Maximum Span Lengths

- 3.1 Span lengths should not exceed 220 feet when installed 6 feet above communication cables on jointly-owned poles.

4.0 Regulation

- 4.1 Installations of multiplex secondary supply shall be made in accordance with G.O. 95, Rule 54.10, and as described herein.

Note: The above rule also applies when installing 300V Duplex and 600V Quadruplex.

5.0 Voltage Drop

- 5.1 Refer to the *Distribution Design Standards (DDS) Manual* to calculate voltage drop and flicker to determine the proper conductor size.

Approved by: 	Triplex/Quadruplex Secondary — General Requirements	CO 108	
Effective Date: 01-25-2019	What's Changed? Added new Subsection 1.2 for requiring use of copper secondary's in areas with high vegetation and rodent population and when replacing aluminum secondary's due to rodent damage.	Sheet 1 of 1	DOH

This page intentionally left blank.

CO 110 Stringing Tensions — Table
Scope CO 110.1 ACSR and Copper Stringing Tensions

Table CO 110–1: Stringing Tensions

Stringing Tensions ^{a/}			
Conductor Type	Wire Size		Rope Tension Per Conductor (lb)
ACSR	#4 ACSR	For stringing use appropriate 130°F Sag Table.	150
	1/0 ACSR		300
	336.4–18/1 kcmil		750
	653.9–18/3 kcmil		1,600
Covered Conductor	1/0 ACSR		300
	336.4–18/1 kcmil		750
	653.9–18/3 kcmil		1,600
	#2 Copper		400
	2/0 Copper		675
	4/0 Copper		1,100
Copper	#6		150
	#4		250
	#2	400	
	2/0	675	
	4/0	1,100	

^{a/} For determining size rope to pull in conductors—these are not guying tensions

Note(s):

- The above tensions are to be used when calculating the size rope for pulling conductors. **After pulling, the wire shall be sagged at the actual temperature.**

Approved by: <i>ajf</i>	Stringing Tensions — Table	CO 110
Effective Date: 01-25-2019	What's Changed? Added new stringing tensions for all Copper covered conductor sizes.	Sheet 1 of 1
		DOH

This page intentionally left blank.

CO 140 Sag Chart #4—336 ACSR

Scope CO 140.1 Sag — Temperature Stringing Table #4 — 336 ACSR for Light-Loading Areas

Table CO 140–1: Sag — Temperature Stringing Table #4 — 336 ACSR for Light-Loading Areas

Span (ft)	Sag					
	Initial Stringing Sag				Final Sag	
	50°F	70°F	90°F	110°F	70°F	130°F
100	0'-2"	0'-4"	0'-5"	0'-7"	0'-5"	1'-5"
120	0'-4"	0'-5"	0'-6"	0'-10"	0'-7"	1'-8"
140	0'-5"	0'-6"	0'-8"	1'-0"	0'-10"	2'-0"
160	0'-6"	0'-7"	0'-11"	1'-4"	1'-0"	2'-4"
180	0'-7"	0'-10"	1'-1"	1'-6"	1'-2"	2'-8"
200	0'-8"	1'-0"	1'-4"	1'-10"	1'-5"	3'-1"
220	0'-11"	1'-2"	1'-7"	2'-1"	1'-8"	3'-5"
240	1'-1"	1'-5"	1'-10"	2'-5"	2'-0"	3'-10"
260	1'-4"	1'-7"	2'-1"	2'-10"	2'-4"	4'-2"
280	1'-6"	1'-11"	2'-6"	3'-1"	2'-7"	4'-8"
300	1'-8"	2'-2"	2'-10"	3'-6"	3'-0"	5'-1"
320	1'-11"	2'-6"	3'-1"	3'-11"	3'-4"	5'-7"
340	2'-2"	2'-10"	3'-6"	4'-4"	3'-8"	6'-1"
360	2'-6"	3'-1"	3'-11"	4'-8"	4'-1"	6'-6"
380	2'-10"	3'-6"	4'-4"	5'-2"	4'-6"	7'-1"
400	3'-2"	3'-11"	4'-8"	5'-0"	5'-0"	7'-7"
420	3'-6"	4'-4"	5'-2"	6'-1"	5'-5"	8'-1"
440	3'-11"	4'-8"	5'-8"	6'-7"	5'-11"	8'-8"
460	4'-4"	5'-2"	6'-2"	7'-1"	6'-5"	9'-2"
480	4'-10"	5'-8"	6'-8"	7'-8"	7'-0"	9'-10"
500	5'-5"	6'-4"	7'-4"	8'-2"	7'-8"	10'-5"

1.0 Guying

Conductor tensions for guying #4 is 604 lb.

Conductor tensions for guying 1/0 is 1,415 lb.

Conductor tensions for guying 336.4 is 2,846 lb.

2.0 Ground Clearance

Use 130°F sags when calculating conductor-to-ground clearances.

Approved by: <i>ajf</i>	Sag Chart #4—336 ACSR	CO 140
Effective Date: 01-25-2019	What's Changed?	Sheet 1 of 9
		DOH

Scope CO 140.2 Sag and Tensions — Temperature Stringing Table 1/0 ACSR Covered Conductor for Light-Loading Areas

Table CO 140–2: Sag — Temperature Stringing Table 17 kV 1/0 ACSR Covered Conductor for Light-Loading Areas

Span (ft)	Sag					
	Initial Stringing Sag				Final Sag	
	50°F	70°F	90°F	110°F	70°F	130°F
100	0'-3"	0'-3"	0'-4"	0'-4"	0'-5"	0'-10"
120	0'-4"	0'-5"	0'-6"	0'-6"	0'-7"	1'-2"
140	0'-6"	0'-7"	0'-8"	0'-9"	0'-10"	1'-6"
160	0'-8"	0'-9"	0'-10"	1'-0"	1'-1"	1'-11"
180	0'-10"	1'-0"	1'-1"	1'-3"	1'-5"	2'-5"
200	1'-1"	1'-3"	1'-5"	1'-7"	1'-9"	2'-10"
220	1'-5"	1'-7"	1'-9"	2'-0"	2'-2"	3'-4"
240	1'-8"	1'-11"	2'-2"	2'-5"	2'-7"	3'-10"
260	2'-1"	2'-3"	2'-7"	2'-11"	3'-1"	4'-5"
280	2'-5"	2'-9"	3'-1"	3'-6"	3'-7"	5'-0"
300	2'-11"	3'-3"	3'-7"	4'-0"	4'-2"	5'-8"
320	3'-5"	3'-9"	4'-2"	4'-8"	4'-9"	6'-4"
340	4'-0"	4'-5"	4'-10"	5'-4"	5'-5"	7'-0"
360	4'-7"	5'-0"	5'-6"	6'-0"	6'-1"	7'-9"
380	5'-3"	5'-9"	6'-3"	6'-9"	6'-10"	8'-7"
400	5'-11"	6'-6"	7'-0"	7'-7"	7'-7"	9'-5"
420	6'-9"	7'-3"	7'-10"	8'-5"	8'-5"	10'-3"
440	7'-6"	8'-1"	8'-8"	9'-3"	9'-4"	11'-2"
460	8'-5"	9'-0"	9'-7"	10'-2"	10'-3"	12'-1"
480	9'-4"	9'-11"	10'-6"	11'-2"	11'-2"	13'-1"
500	10'-3"	10'-11"	11'-6"	12'-2"	12'-2"	14'-1"

CO 140

Sheet 2 of 9

DOH

Sag Chart #4—336 ACSR

What's Changed? Updated temperature stringing sag table for 17 kV 1/0 ACSR Covered Conductor.

Approved by:



Effective Date:

01-25-2019

Table CO 140-3: Tension — Temperature Stringing Table 17 kV 1/0 ACSR Covered Conductor for Light-Loading Areas

Span (ft)	Tension (lb)					
	Initial Stringing Tension				Final Tension	
	50°F	70°F	90°F	110°F	70°F	130°F
100	1,445	1,299	1,146	989	868	437
120	1,419	1,273	1,122	968	858	447
140	1,389	1,244	1,095	945	848	458
160	1,356	1,213	1,067	921	837	468
180	1,321	1,180	1,038	898	826	479
200	1,285	1,146	1,008	876	815	497
220	1,248	1,112	980	855	805	514
240	1,210	1,079	953	836	796	529
260	1,172	1,047	928	820	788	542
280	1,136	1,016	905	805	780	554
300	1,100	988	884	793	773	565
320	1,067	961	866	782	767	575
340	1,036	938	850	773	761	584
360	1,007	916	835	765	756	592
380	980	896	822	758	751	599
400	956	879	811	752	747	606
420	934	863	801	747	744	612
440	914	850	793	743	740	618
460	896	837	785	739	737	623
480	880	826	778	736	735	628
500	866	816	772	733	732	632

Approved by:

ajf

Sag Chart #4—336 ACSR

CO 140

Sheet 3 of 9

Effective Date:
01-25-2019

What's Changed? Added new tension table for 17 kV rated 1/0 ACSR covered conductor.

DOH

Table CO 140-4: Sag — Temperature Stringing Table 35 kV 1/0 ACSR Covered Conductor for Light-Loading Areas

Span (ft)	Sag					
	Initial Stringing Sag				Final Sag	
	50°F	70°F	90°F	110°F	70°F	130°F
100	0'-5"	0'-6"	0'-6"	0'-7"	0'-8"	1'-2"
120	0'-7"	0'-8"	0'-9"	0'-11"	1'-0"	1'-8"
140	0'-10"	1'-0"	1'-1"	1'-3"	1'-4"	2'-1"
160	1'-2"	1'-4"	1'-6"	1'-8"	1'-9"	2'-7"
180	1'-6"	1'-8"	1'-11"	2'-2"	2'-3"	3'-2"
200	2'-0"	2'-2"	2'-5"	2'-8"	2'-9"	3'-9"
220	2'-6"	2'-9"	3'-0"	3'-3"	3'-5"	4'-6"
240	3'-1"	3'-4"	3'-8"	4'-0"	4'-1"	5'-2"
260	3'-8"	4'-0"	4'-4"	4'-8"	4'-10"	6'-0"
280	4'-5"	4'-9"	5'-2"	5'-6"	5'-7"	6'-9"
300	5'-3"	5'-7"	6'-0"	6'-4"	6'-5"	7'-8"
320	6'-1"	6'-6"	6'-11"	7'-3"	7'-4"	8'-8"
340	7'-0"	7'-5"	7'-10"	8'-3"	8'-4"	9'-8"
360	8'-0"	8'-5"	8'-11"	9'-4"	9'-5"	10'-8"
380	9'-1"	9'-6"	10'-0"	10'-5"	10'-6"	11'-10"
400	10'-3"	10'-8"	11'-1"	11'-7"	11'-8"	13'-0"
420	11'-5"	11'-11"	12'-4"	12'-9"	12'-10"	14'-3"
440	12'-8"	13'-2"	13'-7"	14'-1"	14'-2"	15'-6"
460	14'-0"	14'-6"	14'-11"	15'-5"	15'-6"	16'-11"
480	15'-5"	15'-11"	16'-4"	16'-10"	16'-10"	18'-3"
500	16'-10"	17'-4"	17'-10"	18'-3"	18'-4"	19'-9"

CO 140

Sag Chart #4—336 ACSR

Approved by:



Sheet 4 of 9

What's Changed? Added new sag table for 35 kV rated 1/0 ACSR covered conductor.

Effective Date:

DOH

01-25-2019

Table CO 140-5: Tension — Temperature Stringing Table 35 kV 1/0 ACSR Covered Conductor for Light-Loading Areas

Span (ft)	Tension (lb)					
	Initial Stringing Tension				Final Tension	
	50°F	70°F	90°F	110°F	70°F	130°F
100	1,397	1,254	1,109	963	864	482
120	1,355	1,215	1,075	937	855	509
140	1,309	1,174	1,041	913	846	540
160	1,262	1,133	1,008	891	838	566
180	1,215	1,093	978	873	831	589
200	1,169	1,057	952	858	824	608
220	1,126	1,023	929	846	819	626
240	1,087	994	910	836	814	641
260	1,051	968	893	827	810	654
280	1,020	946	879	821	807	665
300	992	926	867	815	804	675
320	969	910	857	811	801	684
340	948	896	849	807	799	692
360	930	884	842	804	797	699
380	915	873	835	801	795	706
400	902	864	830	799	794	711
420	890	856	825	797	792	716
440	880	849	821	795	791	721
460	871	843	817	793	790	725
480	863	838	814	792	789	729
500	856	833	811	791	788	732

1.0 Guying

Conductor tensions for guying 1/0 Covered Conductor is 1,415 lb.

2.0 Ground Clearance

Use 130°F sags when calculating conductor-to-ground clearances.

Scope CO 140.3 Sag — Temperature Stringing Table 336 ACSR Covered Conductor for Light-Loading Areas

Table CO 140-6: Sag — Temperature Stringing Table 17 kV 336 ACSR Covered Conductor for Light-Loading Areas

Span (ft)	Sag					
	Initial Stringing Sag				Final Sag	
	50°F	70°F	90°F	110°F	70°F	130°F
100	0'-3"	0'-3"	0'-4"	0'-5"	0'-6"	1'-4"
120	0'-4"	0'-5"	0'-6"	0'-7"	0'-9"	1'-8"
140	0'-6"	0'-6"	0'-8"	0'-10"	0'-11"	2'-0"
160	0'-7"	0'-9"	0'-10"	1'-1"	1'-3"	2'-5"
180	0'-9"	0'-11"	1'-1"	1'-4"	1'-6"	2'-10"
200	1'-0"	1'-2"	1'-4"	1'-8"	1'-10"	3'-3"
220	1'-2"	1'-5"	1'-8"	2'-0"	2'-3"	3'-8"
240	1'-5"	1'-8"	2'-0"	2'-5"	2'-7"	4'-2"
260	1'-9"	2'-0"	2'-4"	2'-9"	3'-0"	4'-8"
280	2'-0"	2'-4"	2'-9"	3'-3"	3'-6"	5'-3"
300	2'-4"	2'-9"	3'-2"	3'-8"	4'-0"	5'-9"
320	2'-9"	3'-1"	3'-7"	4'-2"	4'-6"	6'-4"
340	3'-1"	3'-7"	4'-1"	4'-8"	5'-0"	7'-0"
360	3'-7"	4'-1"	4'-7"	5'-3"	5'-7"	7'-7"
380	4'-0"	4'-7"	5'-2"	5'-10"	6'-2"	8'-3"
400	4'-6"	5'-1"	5'-9"	6'-6"	6'-10"	9'-0"
420	5'-1"	5'-9"	6'-5"	7'-1"	7'-6"	9'-8"
440	5'-8"	6'-4"	7'-1"	7'-9"	8'-2"	10'-5"
460	6'-3"	7'-0"	7'-9"	8'-6"	8'-11"	11'-3"
480	6'-11"	7'-8"	8'-6"	9'-3"	9'-8"	12'-0"
500	7'-8"	8'-5"	9'-3"	10'-0"	10'-5"	12'-10"

CO 140

Sheet 6 of 9

DOH

Sag Chart #4—336 ACSR

What's Changed? Updated sag table for 17 kV rated 336 ACSR covered conductor.

Approved by:



Effective Date:

01-25-2019

Table CO 140–7: Tension — Temperature Stringing Table 17 kV 336 ACSR Covered Conductor for Light-Loading Areas

Span (ft)	Tension (lb)					
	Initial Stringing Tension				Final Tension	
	50°F	70°F	90°F	110°F	70°F	130°F
100	3,072	2,625	2,151	1,663	1,443	551
120	3,054	2,611	2,145	1,675	1,465	630
140	3,032	2,594	2,138	1,686	1,487	702
160	3,007	2,574	2,129	1,698	1,509	769
180	2,979	2,552	2,120	1,709	1,530	831
200	2,948	2,528	2,109	1,719	1,550	888
220	2,914	2,502	2,098	1,728	1,569	941
240	2,877	2,475	2,086	1,737	1,586	990
260	2,838	2,447	2,074	1,745	1,602	1,037
280	2,797	2,417	2,062	1,752	1,617	1,079
300	2,755	2,388	2,050	1,758	1,631	1,119
320	2,712	2,359	2,038	1,764	1,644	1,157
340	2,668	2,330	2,027	1,769	1,656	1,192
360	2,625	2,302	2,015	1,774	1,667	1,224
380	2,582	2,275	2,005	1,778	1,677	1,255
400	2,540	2,248	1,995	1,781	1,686	1,284
420	2,499	2,224	1,985	1,785	1,694	1,310
440	2,460	2,200	1,976	1,788	1,702	1,336
460	2,422	2,178	1,967	1,790	1,709	1,359
480	2,387	2,157	1,959	1,793	1,716	1,381
500	2,353	2,137	1,952	1,795	1,722	1,402

Approved by:

ajf

Sag Chart #4—336 ACSR

CO 140

Sheet 7 of 9

Effective Date:
01-25-2019

What's Changed? Added new tension table for 17 kV rated 336 ACSR covered conductor.

DOH

Table CO 140–8: Sag — Temperature Stringing Table 35 kV 336 ACSR Covered Conductor for Light-Loading Areas

Span (ft)	Sag					
	Initial Stringing Sag				Final Sag	
	50°F	70°F	90°F	110°F	70°F	130°F
100	0'-4"	0'-5"	0'-6"	0'-7"	0'-8"	1'-5"
120	0'-6"	0'-7"	0'-8"	0'-10"	0'-11"	1'-10"
140	0'-8"	0'-9"	0'-11"	1'-1"	1'-3"	2'-3"
160	0'-10"	1'-0"	1'-2"	1'-5"	1'-7"	2'-8"
180	1'-1"	1'-3"	1'-6"	1'-10"	2'-0"	3'-2"
200	1'-5"	1'-7"	1'-11"	2'-3"	2'-5"	3'-8"
220	1'-9"	2'-0"	2'-4"	2'-8"	2'-11"	4'-3"
240	2'-1"	2'-5"	2'-9"	3'-2"	3'-5"	4'-10"
260	2'-6"	2'-10"	3'-3"	3'-8"	4'-0"	5'-5"
280	3'-0"	3'-4"	3'-9"	4'-3"	4'-7"	6'-1"
300	3'-6"	3'-11"	4'-5"	4'-11"	5'-2"	6'-9"
320	4'-0"	4'-6"	5'-0"	5'-6"	5'-10"	7'-6"
340	4'-8"	5'-2"	5'-8"	6'-3"	6'-7"	8'-3"
360	5'-3"	5'-10"	6'-5"	7'-0"	7'-4"	9'-1"
380	6'-0"	6'-7"	7'-2"	7'-9"	8'-2"	9'-11"
400	6'-9"	7'-4"	8'-0"	8'-7"	9'-0"	10'-10"
420	7'-7"	8'-2"	8'-10"	9'-5"	9'-10"	11'-9"
440	8'-5"	9'-1"	9'-9"	10'-4"	10'-9"	12'-8"
460	9'-4"	10'-0"	10'-8"	11'-4"	11'-9"	13'-8"
480	10'-3"	10'-11"	11'-8"	12'-4"	12'-9"	14'-8"
500	11'-3"	12'-0"	12'-8"	13'-4"	13'-9"	15'-9"

CO 140

Sheet 8 of 9

DOH

Sag Chart #4—336 ACSR

What's Changed? Added new sag table for 35 kV rated 336 ACSR covered conductor.

Approved by:



Effective Date:

01-25-2019

Table CO 140–9: Tension — Temperature Stringing Table 35 kV 336 ACSR Covered Conductor for Light-Loading Areas

Span (ft)	Tension					
	Initial Stringing Tension				Final Tension	
	50°F	70°F	90°F	110°F	70°F	130°F
100	3,058	2,620	2,165	1,712	1,501	706
120	3,031	2,601	2,161	1,735	1,536	800
140	2,999	2,578	2,155	1,756	1,568	884
160	2,961	2,552	2,148	1,775	1,599	961
180	2,919	2,522	2,138	1,792	1,626	1,030
200	2,872	2,490	2,128	1,807	1,651	1,094
220	2,823	2,457	2,117	1,820	1,674	1,151
240	2,771	2,423	2,105	1,832	1,694	1,204
260	2,718	2,389	2,094	1,841	1,713	1,252
280	2,665	2,356	2,082	1,849	1,729	1,297
300	2,613	2,325	2,071	1,856	1,744	1,337
320	2,563	2,294	2,061	1,862	1,757	1,374
340	2,515	2,266	2,051	1,868	1,769	1,408
360	2,470	2,240	2,041	1,872	1,780	1,440
380	2,428	2,216	2,033	1,876	1,790	1,469
400	2,389	2,193	2,024	1,879	1,798	1,495
420	2,353	2,173	2,017	1,882	1,806	1,520
440	2,320	2,154	2,010	1,885	1,813	1,543
460	2,290	2,137	2,004	1,887	1,820	1,564
480	2,263	2,122	1,998	1,889	1,826	1,583
500	2,238	2,108	1,992	1,891	1,831	1,601

1.0 Guying

Conductor tensions for guying 336 Covered Conductor is 2,846 lb.

2.0 Ground Clearance

Use 130°F sags when calculating conductor-to-ground clearances.

Approved by:

ajf

Sag Chart #4—336 ACSR

CO 140

Sheet 9 of 9

Effective Date:
01-25-2019

What's Changed? Added new tension table for 35 kV rated 336 ACSR covered conductor.

DOH

This page intentionally left blank.

CO 142 Sag Chart 653 ACSR

Scope CO 142.1 Sag — Temperature Stringing Table 653 ACSR for Light-Loading Areas

Table CO 142–1: Sag — Temperature Stringing Table 653 ACSR for Light-Loading Areas

Span (ft)	Sag					
	Initial Stringing Sag				Final Sag	
	50°F	70°F	90°F	110°F	70°F	130°F
100	0'-4"	0'-6"	0'-10"	1'-2"	0'-11"	1'-10"
120	0'-6"	0'-8"	1'-1"	1'-6"	1'-2"	2'-2"
140	0'-7"	0'-11"	1'-4"	1'-10"	1'-5"	2'-7"
160	0'-10"	1'-2"	1'-7"	2'-1"	1'-8"	3'-0"
180	1'-0"	1'-5"	2'-0"	2'-6"	2'-1"	3'-6"
200	1'-2"	1'-8"	2'-4"	2'-11"	2'-5"	3'-11"
220	1'-6"	2'-1"	2'-8"	3'-4"	2'-10"	4'-5"
240	1'-10"	2'-5"	3'-1"	3'-8"	3'-2"	4'-11"
260	2'-1"	2'-10"	3'-6"	4'-1"	3'-7"	5'-5"
280	2'-6"	3'-2"	3'-11"	4'-7"	4'-1"	6'-0"
300	2'-11"	3'-7"	4'-5"	5'-1"	4'-7"	6'-6"
320	3'-4"	4'-1"	4'-11"	5'-7"	5'-1"	7'-1"
340	3'-10"	4'-7"	5'-5"	6'-2"	5'-7"	7'-8"
360	4'-4"	5'-1"	6'-0"	6'-8"	6'-1"	8'-4"
380	4'-10"	5'-8"	6'-6"	7'-3"	6'-8"	9'-0"
400	5'-4"	6'-4"	7'-1"	8'-0"	7'-4"	9'-7"
420	5'-11"	6'-11"	7'-10"	8'-7"	8'-0"	10'-4"
440	6'-6"	7'-6"	8'-5"	9'-4"	8'-7"	11'-0"
460	7'-2"	8'-2"	9'-1"	10'-0"	9'-4"	11'-10"
480	7'-11"	8'-11"	9'-10"	10'-8"	10'-0"	12'-6"
500	8'-7"	9'-7"	10'-6"	11'-6"	10'-10"	13'-4"

1.0 Guying

Conductor tensions for guying is 2,846 lb.

2.0 Ground Clearance

Use 130°F sags when calculating conductor-to-ground clearances.

Approved by: 	Sag Chart 653 ACSR	CO 142
Effective Date: 01-25-2019	What's Changed?	Sheet 1 of 5
		DOH

Scope CO 142.2 Sag — Temperature Stringing Table 653 ACSR Covered Conductor for Light-Loading Areas

Table CO 142-2: Sag — Temperature Stringing Table 17 kV 653 ACSR Covered Conductor for Light-Loading Areas

Span (ft)	Sag					
	Initial Stringing Sag				Final Sag	
	50°F	70°F	90°F	110°F	70°F	130°F
100	0'-6"	0'-8"	1'-0"	1'-3"	1'-1"	1'-8"
120	0'-8"	0'-11"	1'-3"	1'-7"	1'-5"	2'-2"
140	0'-11"	1'-3"	1'-7"	1'-11"	1'-9"	2'-9"
160	1'-3"	1'-7"	1'-11"	2'-4"	2'-2"	3'-4"
180	1'-6"	1'-11"	2'-4"	2'-9"	2'-8"	3'-10"
200	1'-11"	2'-4"	2'-9"	3'-3"	3'-2"	4'-5"
220	2'-4"	2'-10"	3'-3"	3'-9"	3'-8"	5'-0"
240	2'-9"	3'-4"	3'-10"	4'-4"	4'-3"	5'-8"
260	3'-4"	3'-10"	4'-5"	4'-11"	4'-10"	6'-4"
280	3'-11"	4'-6"	5'-0"	5'-7"	5'-6"	7'-0"
300	4'-6"	5'-1"	5'-8"	6'-3"	6'-2"	7'-9"
320	5'-2"	5'-10"	6'-5"	7'-0"	6'-11"	8'-7"
340	5'-11"	6'-7"	7'-2"	7'-9"	7'-9"	9'-5"
360	6'-6"	7'-0"	7'-4"	8'-0"	8'-3"	9'-9"
380	7'-3"	7'-10"	8'-2"	8'-10"	9'-2"	10'-8"
400	8'-2"	8'-9"	9'-1"	9'-9"	10'-0"	11'-7"
420	9'-1"	9'-8"	10'-0"	10'-8"	11'-0"	12'-7"
440	10'-0"	10'-8"	11'-0"	11'-8"	12'-0"	13'-7"
460	11'-1"	11'-8"	12'-0"	12'-8"	13'-1"	14'-8"
480	12'-1"	12'-9"	13'-1"	13'-9"	14'-2"	15'-10"
500	13'-3"	13'-11"	14'-3"	14'-11"	15'-4"	17'-0"

CO 142

Sag Chart 653 ACSR

Approved by:



Sheet 2 of 5

What's Changed? Updated sag table for 17 kV rated 653 ACSR covered conductor.

Effective Date:

DOH

01-25-2019

Table CO 142-3: Tension — Temperature Stringing Table 17 kV 653 ACSR Covered Conductor for Light-Loading Areas

Span (ft)	Tension (lb)					
	Initial Stringing Tension				Final Tension	
	50°F	70°F	90°F	110°F	70°F	130°F
100	2,495	1,762	1,261	972	1,148	736
120	2,550	1,870	1,400	1,112	1,257	814
140	2,580	1,952	1,515	1,234	1,351	885
160	2,589	2,013	1,609	1,340	1,432	950
180	2,584	2,059	1,686	1,430	1,503	1,034
200	2,568	2,092	1,750	1,508	1,564	1,112
220	2,545	2,115	1,803	1,576	1,618	1,183
240	2,519	2,132	1,846	1,634	1,665	1,248
260	2,491	2,143	1,882	1,684	1,706	1,308
280	2,464	2,151	1,912	1,728	1,742	1,364
300	2,437	2,155	1,937	1,765	1,775	1,414
320	2,411	2,158	1,958	1,798	1,803	1,461
340	2,388	2,159	1,976	1,827	1,829	1,503
360	3,306	2,257	2,159	1,991	1,921	1,629
380	3,271	2,248	2,159	2,004	1,936	1,662
400	3,239	2,239	2,158	2,015	1,950	1,691
420	3,209	2,231	2,156	2,025	1,963	1,719
440	3,183	2,223	2,155	2,033	1,974	1,744
460	3,158	2,216	2,153	2,040	1,984	1,766
480	3,136	2,210	2,152	2,047	1,993	1,787
500	3,116	2,204	2,150	2,052	2,001	1,807

Approved by:

ajf

Sag Chart 653 ACSR

CO 142

Effective Date:
01-25-2019

What's Changed? Added new tension table for 17 kV rated 653 ACSR covered conductor.

Sheet 3 of 5

DOH

Table CO 142-4: Sag — Temperature Stringing Table 35 kV 653 ACSR Covered Conductor for Light-Loading Areas

Span (ft)	Sag					
	Initial Stringing Sag				Final Sag	
	50°F	70°F	90°F	110°F	70°F	130°F
100	0'-7"	0'-10"	1'-1"	1'-4"	1'-2"	1'-10"
120	0'-10"	1'-1"	1'-5"	1'-8"	1'-7"	2'-5"
140	1'-2"	1'-6"	1'-9"	2'-1"	2'-0"	3'-0"
160	1'-6"	1'-10"	2'-3"	2'-7"	2'-6"	3'-6"
180	1'-11"	2'-4"	2'-9"	3'-1"	3'-0"	4'-2"
200	2'-5"	2'-10"	3'-3"	3'-8"	3'-8"	4'-9"
220	3'-0"	3'-5"	3'-10"	4'-3"	4'-3"	5'-6"
240	3'-7"	4'-1"	4'-6"	5'-0"	5'-0"	6'-3"
260	4'-3"	4'-9"	5'-3"	5'-8"	5'-9"	7'-0"
280	5'-0"	5'-6"	6'-0"	6'-6"	6'-6"	7'-10"
300	5'-10"	6'-4"	6'-10"	7'-4"	7'-4"	8'-9"
320	6'-8"	7'-3"	7'-9"	8'-3"	8'-3"	9'-9"
340	7'-7"	8'-2"	8'-8"	9'-2"	9'-3"	10'-9"
360	8'-7"	9'-2"	9'-8"	10'-3"	10'-3"	11'-9"
380	9'-8"	10'-3"	10'-9"	11'-3"	11'-4"	12'-11"
400	10'-9"	11'-4"	11'-11"	12'-5"	12'-6"	14'-1"
420	11'-11"	12'-6"	13'-1"	13'-7"	13'-8"	15'-3"
440	13'-2"	13'-9"	14'-4"	14'-10"	15'-0"	16'-7"
460	14'-6"	15'-1"	15'-7"	16'-2"	16'-3"	17'-11"
480	15'-10"	16'-5"	17'-0"	17'-6"	17'-8"	19'-3"
500	17'-3"	17'-10"	18'-5"	19'-0"	19'-1"	20'-9"

CO 142

Sheet 4 of 5

DOH

Sag Chart 653 ACSR

What's Changed? Added new sag table for 35 kV rated 653 ACSR covered conductor.

Approved by:

a/j

Effective Date:

01-25-2019

Table CO 142-5: Tension — Temperature Stringing Table 35 kV 653 ACSR Covered Conductor for Light-Loading Areas

Span (ft)	Tension					
	Initial Stringing Tension				Final Tension	
	50°F	70°F	90°F	110°F	70°F	130°F
100	2,592	1,924	1,458	1,166	1,300	843
120	2,624	2,020	1,594	1,314	1,413	929
140	2,628	2,087	1,701	1,437	1,508	1,031
160	2,613	2,132	1,785	1,539	1,588	1,130
180	2,587	2,162	1,851	1,623	1,656	1,220
200	2,555	2,182	1,903	1,694	1,714	1,301
220	2,521	2,194	1,945	1,753	1,763	1,374
240	2,488	2,201	1,978	1,802	1,805	1,439
260	2,457	2,204	2,004	1,844	1,842	1,498
280	2,428	2,206	2,026	1,879	1,873	1,551
300	2,403	2,206	2,044	1,909	1,901	1,598
320	2,380	2,205	2,058	1,935	1,925	1,641
340	2,359	2,203	2,071	1,957	1,946	1,680
360	2,341	2,201	2,081	1,976	1,964	1,715
380	2,325	2,199	2,089	1,993	1,980	1,747
400	2,311	2,197	2,096	2,008	1,995	1,776
420	2,298	2,195	2,103	2,020	2,008	1,802
440	2,287	2,193	2,108	2,032	2,019	1,826
460	2,277	2,191	2,113	2,042	2,029	1,848
480	2,268	2,189	2,117	2,051	2,039	1,867
500	2,260	2,187	2,120	2,059	2,047	1,886

1.0 Guying

Conductor tensions for guying 653.9 Covered Conductor is 2,846 lb.

2.0 Ground Clearance

Use 130°F sags when calculating conductor-to-ground clearances.

This page intentionally left blank.

CO 148 Sag Chart #6 — 4/0 Copper

Scope CO 148.1 Sag — Temperature Stringing Table #6 — 4/0 Copper for Light Loading Areas

Table CO 148-1: Sag — Temperature Stringing Table #6 — 4/0 Copper for Light Loading Areas

Span (ft)	Sag					
	Initial Stringing Sag				Final Sag	
	50°F	70°F	90°F	110°F	70°F	130°F
100	0'-5"	0'-6"	0'-8"	0'-11"	0'-10"	1'-6"
120	0'-7"	0'-8"	0'-11"	1'-2"	1'-0"	1'-11"
140	0'-8"	0'-11"	1'-2"	1'-6"	1'-4"	2'-2"
160	0'-11"	1'-2"	1'-6"	1'-10"	1'-8"	2'-8"
180	1'-2"	1'-6"	1'-11"	2'-2"	2'-1"	3'-1"
200	1'-6"	1'-11"	2'-4"	2'-8"	2'-6"	3'-7"
220	1'-11"	2'-4"	2'-8"	3'-1"	3'-0"	4'-1"
240	2'-4"	2'-10"	3'-2"	3'-7"	3'-6"	4'-8"
260	2'-11"	3'-4"	3'-8"	4'-2"	4'-0"	5'-4"
280	3'-4"	3'-10"	4'-4"	4'-10"	4'-7"	5'-11"
300	3'-10"	4'-5"	4'-11"	5'-5"	5'-2"	6'-7"
320	4'-6"	5'-0"	5'-7"	6'-1"	5'-11"	7'-4"
340	5'-2"	5'-8"	6'-2"	6'-10"	6'-8"	8'-0"
360	5'-11"	6'-5"	7'-0"	7'-6"	7'-4"	8'-10"
380	6'-7"	7'-1"	7'-10"	8'-4"	8'-0"	9'-7"
400	7'-5"	8'-0"	8'-7"	9'-1"	8'-11"	10'-6"
420	8'-2"	8'-10"	9'-6"	10'-0"	9'-10"	11'-5"
440	9'-0"	9'-8"	10'-4"	10'-11"	10'-8"	12'-4"
460	10'-0"	10'-8"	11'-4"	11'-10"	11'-7"	13'-2"
480	11'-0"	11'-8"	12'-2"	12'-11"	12'-7"	14'-4"
500	12'-0"	12'-6"	13'-4"	13'-10"	13'-7"	15'-4"

1.0 Guying

Conductor tensions for guying #6 is 320 lb.

Conductor tensions for guying #4 is 484 lb.

Conductor tensions for guying #2 is 761 lb.

Conductor tensions for guying 2/0 is 1,482 lb.

Conductor tensions for guying 4/0 is 2,288 lb.

2.0 Ground Clearance

Use 130°F sags when calculating conductor to ground clearances.

Scope CO 148.2 Sag — Temperature Stringing Table #2 Copper Covered Conductor for Light-Loading Areas

Table CO 148-2: Sag — Temperature Stringing Table 17 kV #2 Copper Covered Conductor for Light-Loading Areas

Span (ft)	Sag					
	Initial Stringing Sag				Final Sag	
	50°F	70°F	90°F	110°F	70°F	130°F
100	0'-7"	0'-8"	0'-10"	1'-0"	0'-9"	1'-3"
120	0'-10"	1'-0"	1'-2"	1'-4"	1'-0"	1'-8"
140	1'-2"	1'-4"	1'-6"	1'-9"	1'-5"	2'-2"
160	1'-6"	1'-9"	2'-0"	2'-3"	1'-10"	2'-8"
180	2'-0"	2'-3"	2'-6"	2'-9"	2'-4"	3'-2"
200	2'-6"	2'-9"	3'-1"	3'-4"	2'-10"	3'-10"
220	3'-1"	3'-4"	3'-8"	4'-0"	3'-6"	4'-6"
240	3'-8"	4'-0"	4'-4"	4'-8"	4'-2"	5'-2"
260	4'-5"	4'-9"	5'-1"	5'-5"	4'-10"	5'-11"
280	5'-2"	5'-6"	5'-10"	6'-3"	5'-8"	6'-9"
300	5'-11"	6'-4"	6'-9"	7'-1"	6'-6"	7'-7"
320	6'-10"	7'-3"	7'-7"	8'-0"	7'-5"	8'-6"
340	7'-9"	8'-2"	8'-7"	9'-0"	8'-4"	9'-6"
360	8'-9"	9'-2"	9'-7"	10'-0"	9'-4"	10'-7"
380	9'-10"	10'-3"	10'-8"	11'-1"	10'-5"	11'-8"
400	11'-0"	11'-5"	11'-10"	12'-3"	11'-7"	12'-9"
420	12'-2"	12'-7"	13'-0"	13'-5"	12'-9"	14'-0"
440	13'-5"	13'-10"	14'-3"	14'-8"	14'-0"	15'-3"
460	14'-8"	15'-2"	15'-7"	16'-0"	15'-3"	16'-7"
480	16'-0"	16'-6"	16'-11"	17'-4"	16'-8"	18'-0"
500	17'-6"	17'-11"	18'-4"	18'-9"	18'-1"	19'-5"

CO 148

Sag Chart #6 — 4/0 Copper

Approved by:



Sheet 2 of 7

What's Changed? Updated sag values for 17 kV rated #2 copper covered conductor.

Effective Date:

DOH

01-25-2019

Table CO 148-3: Tension — Temperature Stringing Table 17 kV #2 Copper Covered Conductor for Light-Loading Areas

Span (ft)	Tension (lb)					
	Initial Stringing Tension				Final Tension	
	50°F	70°F	90°F	110°F	70°F	130°F
100	708	592	490	407	553	313
120	694	588	497	424	553	341
140	679	584	503	438	552	364
160	665	580	509	451	552	385
180	652	577	514	462	552	402
200	640	574	518	472	552	418
220	630	571	522	480	552	431
240	621	569	525	487	552	443
260	613	567	527	494	551	453
280	606	565	530	499	551	462
300	600	563	532	504	551	470
320	595	562	534	508	551	477
340	590	561	535	512	551	483
360	587	560	536	515	551	488
380	583	559	538	518	551	493
400	580	559	539	521	551	498
420	578	558	540	523	551	502
440	575	557	541	525	551	505
460	573	557	541	527	551	508
480	572	556	542	529	551	511
500	570	556	543	530	551	514

1.0 Guying

Conductor tensions for guying #2 copper covered conductor is 925 lb.

2.0 Ground Clearance

Use 130°F sags when calculating conductor-to-ground clearances.

Scope CO 148.3 Sag — Temperature Stringing Table 2/0 Copper Covered Conductor for Light-Loading Areas

Table CO 148-4: Sag — Temperature Stringing Table 17 kV 2/0 Copper Covered Conductor for Light-Loading Areas

Span (ft)	Sag					
	Initial Stringing Sag				Final Sag	
	50°F	70°F	90°F	110°F	70°F	130°F
100	0'-6"	0'-7"	0'-9"	0'-11"	0'-8"	1'-2"
120	0'-8"	0'-10"	1'-0"	1'-2"	0'-11"	1'-6"
140	1'-0"	1'-2"	1'-4"	1'-7"	1'-2"	1'-11"
160	1'-3"	1'-6"	1'-8"	2'-0"	1'-6"	2'-4"
180	1'-7"	1'-10"	2'-1"	2'-5"	1'-11"	2'-10"
200	2'-0"	2'-3"	2'-7"	2'-10"	2'-4"	3'-4"
220	2'-5"	2'-9"	3'-0"	3'-4"	2'-10"	3'-10"
240	2'-11"	3'-3"	3'-7"	3'-11"	3'-4"	4'-5"
260	3'-5"	3'-9"	4'-1"	4'-6"	3'-10"	5'-0"
280	3'-11"	4'-4"	4'-9"	5'-1"	4'-5"	5'-8"
300	4'-7"	4'-11"	5'-4"	5'-9"	5'-1"	6'-4"
320	5'-2"	5'-7"	6'-0"	6'-6"	5'-9"	7'-0"
340	5'-10"	6'-4"	6'-9"	7'-2"	6'-5"	7'-9"
360	6'-7"	7'-1"	7'-6"	8'-0"	7'-2"	8'-7"
380	7'-4"	7'-10"	8'-4"	8'-9"	8'-0"	9'-5"
400	8'-2"	8'-8"	9'-2"	9'-8"	8'-10"	10'-3"
420	9'-0"	9'-6"	10'-0"	10'-6"	9'-8"	11'-2"
440	9'-11"	10'-6"	11'-0"	11'-6"	10'-7"	12'-1"
460	10'-11"	11'-5"	11'-11"	12'-5"	11'-7"	13'-1"
480	11'-10"	12'-5"	12'-11"	13'-5"	12'-6"	14'-1"
500	12'-11"	13'-5"	14'-0"	14'-6"	13'-7"	15'-2"

CO 148

Sheet 4 of 7

DOH

Sag Chart #6 — 4/0 Copper

What's Changed? Updated sag values for 17 kV rated 2/0 copper covered conductor.

Approved by:



Effective Date:

01-25-2019

Table CO 148–5: Tension — Temperature Stringing Table 17 kV 2/0 Copper Covered Conductor for Light-Loading Areas

Span (ft)	Tension (lb)					
	Initial Stringing Tension				Final Tension	
	50°F	70°F	90°F	110°F	70°F	130°F
100	1,432	1,189	970	789	1,112	590
120	1,426	1,198	997	833	1,128	651
140	1,420	1,207	1,023	873	1,144	706
160	1,414	1,216	1,047	909	1,159	755
180	1,408	1,225	1,069	942	1,174	799
200	1,402	1,233	1,090	972	1,187	839
220	1,396	1,240	1,109	1,000	1,198	876
240	1,391	1,247	1,126	1,024	1,209	909
260	1,386	1,253	1,141	1,047	1,219	938
280	1,381	1,259	1,155	1,067	1,228	966
300	1,377	1,264	1,168	1,086	1,236	990
320	1,373	1,269	1,180	1,103	1,243	1,013
340	1,370	1,273	1,190	1,118	1,249	1,034
360	1,366	1,277	1,200	1,132	1,255	1,053
380	1,363	1,281	1,209	1,145	1,260	1,070
400	1,361	1,284	1,216	1,157	1,265	1,086
420	1,358	1,287	1,224	1,167	1,269	1,101
440	1,356	1,290	1,230	1,177	1,273	1,115
460	1,354	1,292	1,237	1,186	1,277	1,127
480	1,353	1,294	1,242	1,195	1,280	1,139
500	1,351	1,297	1,247	1,202	1,283	1,149

1.0 Guying

Conductor tensions for guying 2/0 copper covered conductor is 1,800 lb.

2.0 Ground Clearance

Use 130°F sags when calculating conductor-to-ground clearances.

Scope CO 148.4 Sag — Temperature Stringing Table 4/0 Copper Covered Conductor for Light-Loading Areas

Table CO 148–6: Sag - Temperature Stringing Table 17 kV 4/0 Copper Covered Conductor for Light-Loading Areas

Span (ft)	Sag					
	Initial Stringing Sag				Final Sag	
	50°F	70°F	90°F	110°F	70°F	130°F
100	0'-6"	0'-7"	0'-8"	0'-10"	0'-7"	1'-2"
120	0'-8"	0'-10"	1'-0"	1'-2"	0'-10"	1'-6"
140	0'-11"	1'-1"	1'-3"	1'-6"	1'-2"	1'-11"
160	1'-2"	1'-5"	1'-8"	1'-11"	1'-6"	2'-3"
180	1'-6"	1'-9"	2'-0"	2'-4"	1'-10"	2'-9"
200	1'-10"	2'-1"	2'-5"	2'-9"	2'-2"	3'-2"
220	2'-3"	2'-6"	2'-10"	3'-2"	2'-8"	3'-8"
240	2'-8"	3'-0"	3'-4"	3'-8"	3'-1"	4'-3"
260	3'-1"	3'-6"	3'-10"	4'-3"	3'-7"	4'-9"
280	3'-7"	4'-0"	4'-5"	4'-10"	4'-1"	5'-4"
300	4'-2"	4'-7"	5'-0"	5'-5"	4'-8"	6'-0"
320	4'-9"	5'-2"	5'-7"	6'-0"	5'-3"	6'-7"
340	5'-4"	5'-9"	6'-3"	6'-8"	5'-11"	7'-3"
360	6'-0"	6'-5"	6'-11"	7'-5"	6'-7"	8'-0"
380	6'-8"	7'-2"	7'-7"	8'-1"	7'-3"	8'-9"
400	7'-4"	7'-10"	8'-4"	8'-10"	8'-0"	9'-6"
420	8'-1"	8'-8"	9'-2"	9'-8"	8'-9"	10'-4"
440	8'-11"	9'-5"	10'-0"	10'-6"	9'-7"	11'-2"
460	9'-9"	10'-3"	10'-10"	11'-4"	10'-5"	12'-0"
480	10'-7"	11'-2"	11'-8"	12'-3"	11'-3"	12'-11"
500	11'-6"	12'-1"	12'-7"	13'-2"	12'-2"	13'-10"

CO 148

Sheet 6 of 7

DOH

Sag Chart #6 — 4/0 Copper

What's Changed? Updated sag values for 17 kV rated 4/0 copper covered conductor.

Approved by:



Effective Date:

01-25-2019

Table CO 148–7: Tension — Temperature Stringing Table 17 kV 4/0 Copper Covered Conductor for Light-Loading Areas

Span (ft)	Tension					
	Initial Stringing Tension				Final Tension	
	50°F	70°F	90°F	110°F	70°F	130°F
100	2,224	1,834	1,484	1,196	1,716	887
120	2,226	1,858	1,535	1,271	1,752	986
140	2,229	1,883	1,584	1,341	1,787	1,076
160	2,231	1,907	1,630	1,405	1,821	1,158
180	2,234	1,931	1,674	1,463	1,853	1,232
200	2,237	1,953	1,714	1,518	1,883	1,300
220	2,239	1,975	1,752	1,568	1,911	1,363
240	2,242	1,995	1,787	1,614	1,937	1,420
260	2,244	2,014	1,819	1,656	1,961	1,474
280	2,246	2,031	1,849	1,695	1,983	1,523
300	2,248	2,047	1,876	1,731	2,003	1,568
320	2,250	2,062	1,901	1,764	2,022	1,610
340	2,252	2,076	1,925	1,795	2,039	1,648
360	2,253	2,089	1,946	1,823	2,055	1,684
380	2,255	2,100	1,966	1,850	2,069	1,718
400	2,256	2,111	1,985	1,874	2,082	1,748
420	2,257	2,121	2,002	1,897	2,094	1,777
440	2,258	2,131	2,018	1,917	2,105	1,804
460	2,260	2,139	2,032	1,937	2,116	1,829
480	2,261	2,147	2,046	1,955	2,125	1,852
500	2,261	2,154	2,058	1,972	2,134	1,874

3.0 Guying

Conductor tensions for guying 4/0 copper covered conductor is 2,780 lb.

4.0 Ground Clearance

Use 130°F sags when calculating conductor-to-ground clearances.

This page intentionally left blank.

CO 152 Sag Chart #2 Copper

Scope CO 152.1 Sag — Temperature Stringing Table #2 Copper for Heavy-Loading Areas

Table CO 152-1: Sag — Temperature Stringing Table #2 Copper for Heavy-Loading Areas

Span (ft)	Sag					
	Initial Stringing Sag				Final Sag	
	50°F	70°F	90°F	110°F	70°F	130°F
100	1'-2"	1'-7"	1'-11"	2'-2"	1'-11"	2'-8"
120	1'-8"	2'-1"	2'-6"	2'-10"	2'-6"	3'-5"
140	2'-4"	2'-8"	3'-1"	3'-6"	3'-1"	4'-1"
160	2'-11"	3'-5"	3'-10"	4'-2"	3'-10"	4'-11"
180	3'-8"	4'-2"	4'-7"	5'-0"	4'-7"	5'-8"
200	4'-6"	5'-0"	5'-6"	5'-11"	5'-5"	6'-8"
220	5'-5"	6'-0"	6'-5"	6'-11"	6'-5"	7'-8"
240	6'-5"	7'-0"	7'-6"	7'-11"	7'-5"	8'-8"
260	7'-6"	8'-1"	8'-7"	9'-1"	8'-6"	9'-11"
280	8'-8"	9'-4"	9'-10"	10'-4"	9'-8"	11'-1"
300	10'-0"	10'-6"	11'-1"	11'-7"	11'-0"	12'-5"
320	11'-5"	11'-11"	12'-5"	12'-11"	12'-5"	13'-10"
340	12'-10"	13'-5"	13'-11"	14'-5"	13'-10"	15'-4"
360	14'-4"	14'-11"	15'-5"	15'-11"	15'-5"	16'-11"
380	16'-0"	16'-6"	17'-1"	17'-7"	17'-0"	18'-6"
400	17'-8"	18'-2"	18'-10"	19'-4"	18'-8"	20'-4"
420	19'-6"	20'-0"	20'-7"	21'-1"	20'-6"	22'-1"
440	21'-4"	21'-11"	22'-6"	23'-0"	22'-5"	24'-0"
460	23'-4"	23'-11"	24'-5"	25'-0"	24'-5"	26'-0"
480	25'-5"	25'-11"	26'-6"	27'-0"	26'-4"	28'-0"
500	27'-5"	28'-1"	28'-7"	29'-2"	28'-7"	30'-2"

1.0 Guying

Conductor tensions for guying is 761 lb.

2.0 Ground Clearance

Use 130°F sags when calculating conductor-to-ground clearances.

Approved by: <i>ajf</i>	Sag Chart #2 Copper	CO 152
Effective Date: 01-25-2019	What's Changed?	Sheet 1 of 3
		DOH

Scope CO 152.2 Sag — Temperature Stringing Table #2 Copper Covered Conductor for Heavy Loading Areas

Table CO 152-2: Sag — Temperature Stringing Table 17 kV #2 Copper Covered Conductor for Heavy-Loading Areas

Span (ft)	Sag					
	Initial Stringing Sag				Final Sag	
	50°F	70°F	90°F	110°F	70°F	130°F
100	1'-4"	1'-6"	1'-9"	1'-11"	1'-8"	2'-2"
120	2'-1"	2'-4"	2'-6"	2'-8"	2'-5"	2'-11"
140	3'-0"	3'-3"	3'-5"	3'-7"	3'-4"	3'-11"
160	4'-1"	4'-3"	4'-6"	4'-8"	4'-5"	5'-0"
180	5'-4"	5'-6"	5'-8"	5'-11"	5'-8"	6'-2"
200	6'-8"	6'-10"	7'-1"	7'-3"	7'-0"	7'-7"
220	8'-2"	8'-5"	8'-7"	8'-9"	8'-6"	9'-1"
240	9'-10"	10'-0"	10'-3"	10'-5"	10'-2"	10'-9"
260	11'-8"	11'-10"	12'-0"	12'-3"	12'-0"	12'-6"
280	13'-7"	13'-9"	14'-0"	14'-2"	13'-11"	14'-6"
300	15'-8"	15'-11"	16'-1"	16'-3"	16'-0"	16'-7"
320	18'-0"	18'-2"	18'-4"	18'-7"	18'-3"	18'-10"
340	20'-4"	20'-7"	20'-9"	21'-0"	20'-8"	21'-3"
360	22'-11"	23'-2"	23'-4"	23'-6"	23'-3"	23'-10"
380	25'-8"	25'-10"	26'-1"	26'-3"	26'-0"	26'-7"
400	28'-7"	28'-9"	28'-11"	29'-2"	28'-11"	29'-6"
420	31'-7"	31'-10"	32'-0"	32'-2"	31'-11"	32'-6"
440	34'-10"	35'-0"	35'-3"	35'-5"	35'-2"	35'-9"
460	38'-2"	38'-5"	38'-7"	38'-9"	38'-6"	39'-1"
480	41'-9"	41'-11"	42'-2"	42'-4"	42'-1"	42'-8"
500	45'-5"	45'-8"	45'-10"	46'-0"	45'-9"	46'-4"

CO 152

Sag Chart #2 Copper

Approved by:



Sheet 2 of 3

What's Changed? Updated sag values for 17 kV rated #2 copper covered conductor.

Effective Date:

DOH

01-25-2019

Table CO 152-3: Tension — Temperature Stringing Table 17 kV #2 Copper Covered Conductor for Heavy-Loading Areas

Span (ft)	Tension (lb)					
	Initial Stringing Tension				Final Tension	
	50°F	70°F	90°F	110°F	70°F	130°F
100	295	259	232	211	241	185
120	271	248	230	214	236	194
140	257	241	228	217	232	200
160	248	237	227	218	230	205
180	243	234	226	219	229	208
200	239	232	225	220	228	211
220	236	230	225	220	227	213
240	234	229	225	221	226	214
260	232	228	224	221	226	216
280	231	227	224	221	225	217
300	230	227	224	221	225	217
320	229	226	224	222	225	218
340	228	226	224	222	225	219
360	227	226	224	222	224	219
380	227	225	224	222	224	219
400	227	225	224	222	224	220
420	226	225	224	222	224	220
440	226	225	223	222	224	220
460	226	225	223	222	224	221
480	225	224	223	222	224	221
500	225	224	223	222	224	221

1.0 Guying

Conductor tensions for guying #2 copper covered conductor is 925 lb.

2.0 Ground Clearance

Use 130°F sags when calculating conductor-to-ground clearances.

This page intentionally left blank.

CO 160 Sag Chart 2/0 and 4/0 Copper

Scope CO 160.1 Sag — Temperature Stringing Table 2/0 and 4/0 Copper for Heavy-Loading Areas

Table CO 160–1: Sag — Temperature Stringing Table 2/0 and 4/0 Copper for Heavy-Loading Areas

Span (ft)	Sag					
	Initial Stringing Sag				Final Sag	
	50°F	70°F	90°F	110°F	70°F	130°F
100	1'-0"	1'-5"	1'-10"	2'-1"	1'-10"	2'-7"
120	1'-5"	1'-10"	2'-4"	2'-7"	2'-2"	3'-2"
140	1'-10"	2'-4"	2'-8"	3'-1"	2'-8"	3'-10"
160	2'-2"	2'-10"	3'-4"	3'-8"	3'-2"	4'-5"
180	2'-10"	3'-4"	3'-11"	4'-4"	3'-10"	5'-1"
200	3'-4"	3'-11"	4'-6"	5'-0"	4'-5"	5'-10"
220	3-11"	4'-7"	5'-2"	5'-8"	5'-1"	6'-7"
240	4'-7"	5'-4"	5'-11"	6'-6"	5'-10"	7'-5"
260	5'-4"	6'-0"	6'-8"	7'-2"	6'-7"	8'-4"
280	6'-1"	6'-10"	7'-6"	8'-1"	7'-5"	9'-1"
300	7'-0"	7'-8"	8'-5"	9'-0"	8'-4"	10'-1"
320	7'-11"	8'-7"	9'-4"	9'-11"	9'-2"	11'-1"
340	8'-10"	9'-7"	10'-4"	10'-11"	10'-2"	12'-1"
360	9'-10"	10'-7"	11'-4"	12'-0"	11'-2"	13'-2"
380	10'-11"	11'-8"	12'-5"	13'-1"	12'-3"	14'-4"
400	12'-0"	12'-10"	13'-6"	14'-2"	13'-5"	15'-6"
420	13'-2"	14'-0"	14'-8"	15'-5"	14'-7"	16'-8"
440	14'-5"	15'-2"	16'-0"	16'-8"	15'-11"	18'-0"
460	15'-8"	16'-6"	17'-4"	18'-0"	17'-2"	19'-4"
480	17'-1"	17'-11"	18'-7"	19'-5"	18'-7"	20'-8"
500	18'-6"	19'-4"	20'-1"	20'-10"	20'-0"	22'-2"

1.0 Guying

Conductor tensions for guying 2/0 is 1,482 lb.

Conductor tensions for guying 4/0 is 2,288 lb.

2.0 Ground Clearance

Use 130°F sags when calculating conductor-to-ground clearances.

Approved by: <i>ajf</i>	Sag Chart 2/0 and 4/0 Copper	CO 160
Effective Date: 01-25-2019	What's Changed?	Sheet 1 of 5
		DOH

Scope CO 160.2 Sag — Temperature Stringing Table 2/0 Copper Covered Conductor for Heavy Loading Areas

Table CO 160–2: Sag — Temperature Stringing Table 17 kV 2/0 Copper Covered Conductor for Heavy-Loading Areas

Span (ft)	Sag					
	Initial Stringing Sag				Final Sag	
	50°F	70°F	90°F	110°F	70°F	130°F
100	0'-10"	1'-0"	1'-2"	1'-5"	1'-1"	1'-8"
120	1'-3"	1'-6"	1'-8"	1'-11"	1'-7"	2'-3"
140	1'-9"	2'-0"	2'-3"	2'-6"	2'-2"	2'-10"
160	2'-5"	2'-8"	3'-0"	3'-2"	2'-10"	3'-7"
180	3'-2"	3'-5"	3'-9"	4'-0"	3'-7"	4'-4"
200	4'-0"	4'-4"	4'-7"	4'-10"	4'-5"	5'-3"
220	4'-11"	5'-3"	5'-6"	5'-9"	5'-5"	6'-2"
240	6'-0"	6'-3"	6'-7"	6'-10"	6'-5"	7'-3"
260	7'-1"	7'-5"	7'-8"	8'-0"	7'-6"	8'-5"
280	8'-3"	8'-7"	8'-11"	9'-2"	8'-9"	9'-7"
300	9'-7"	9'-11"	10'-2"	10'-6"	10'-1"	10'-11"
320	11'-0"	11'-3"	11'-7"	11'-11"	11'-6"	12'-4"
340	12'-6"	12'-9"	13'-1"	13'-5"	12'-11"	13'-10"
360	14'-1"	14'-4"	14'-8"	15'-0"	14'-6"	15'-5"
380	15'-9"	16'-0"	16'-4"	16'-8"	16'-2"	17'-1"
400	17'-6"	17'-10"	18'-1"	18'-5"	18'-0"	18'-10"
420	19'-4"	19'-8"	20'-0"	20'-3"	19'-10"	20'-9"
440	21'-4"	21'-7"	21'-11"	22'-3"	21'-9"	22'-8"
460	23'-4"	23'-8"	24'-0"	24'-3"	23'-10"	24'-9"
480	25'-6"	25'-10"	26'-1"	26'-5"	26'-0"	26'-11"
500	27'-9"	28'-1"	28'-4"	28'-8"	28'-3"	29'-2"

CO 160

Sag Chart 2/0 and 4/0 Copper

Approved by:

a/j

Sheet 2 of 5

What's Changed? Updated sag values for 17 kV rated 2/0 copper covered conductor.

Effective Date:

DOH

01-25-2019

Table CO 160–3: Tension — Temperature Stringing Table 17 kV 2/0 Copper Covered Conductor for Heavy-Loading Areas

Span (ft)	Tension (lb)					
	Initial Stringing Tension				Final Tension	
	50°F	70°F	90°F	110°F	70°F	130°F
100	852	697	584	501	631	411
120	800	681	592	525	629	447
140	760	669	598	543	628	476
160	731	660	603	556	627	498
180	710	653	606	567	626	517
200	694	648	609	576	626	532
220	682	644	611	583	625	544
240	672	641	613	588	625	554
260	665	638	614	593	625	562
280	659	636	615	596	625	569
300	655	635	616	599	624	575
320	651	633	617	602	624	580
340	648	632	618	604	624	585
360	645	631	618	606	624	589
380	643	630	619	608	624	592
400	641	630	619	609	624	595
420	639	629	620	611	624	597
440	638	629	620	612	624	599
460	636	628	620	613	624	601
480	635	628	620	613	624	603
500	634	627	621	614	624	605

1.0 Guying

Conductor tensions for guying 2/0 copper covered conductor is 1,800 lb.

2.0 Ground Clearance

Use 130°F sags when calculating conductor-to-ground clearances.

Scope CO 160.3 Sag — Temperature Stringing Table 4/0 Copper Covered Conductor for Heavy Loading Areas

Table CO 160-4: Sag — Temperature Stringing Table 17 kV 4/0 Copper Covered Conductor for Heavy-Loading Areas

Span (ft)	Sag					
	Initial Stringing Sag				Final Sag	
	50°F	70°F	90°F	110°F	70°F	130°F
100	0'-8"	0'-10"	1'-1"	1'-3"	1'-0"	1'-7"
120	1'-0"	1'-3"	1'-6"	1'-8"	1'-4"	2'-1"
140	1'-6"	1'-8"	2'-0"	2'-2"	1'-10"	2'-7"
160	1'-11"	2'-3"	2'-6"	2'-9"	2'-4"	3'-2"
180	2'-6"	2'-10"	3'-1"	3'-5"	3'-0"	3'-10"
200	3'-2"	3'-6"	3'-9"	4'-1"	3'-7"	4'-6"
220	3'-10"	4'-2"	4'-6"	4'-10"	4'-4"	5'-3"
240	4'-8"	5'-0"	5'-4"	5'-8"	5'-2"	6'-1"
260	5'-6"	5'-10"	6'-3"	6'-6"	6'-0"	7'-0"
280	6'-5"	6'-10"	7'-2"	7'-6"	7'-0"	8'-0"
300	7'-6"	7'-10"	8'-2"	8'-6"	8'-0"	9'-0"
320	8'-6"	8'-11"	9'-3"	9'-7"	9'-1"	10'-1"
340	9'-8"	10'-1"	10'-5"	10'-9"	10'-3"	11'-3"
360	10'-11"	11'-3"	11'-8"	12'-0"	11'-5"	12'-6"
380	12'-2"	12'-7"	12'-11"	13'-4"	12'-9"	13'-10"
400	13'-6"	13'-11"	14'-4"	14'-8"	14'-1"	15'-2"
420	15'-0"	15'-4"	15'-9"	16'-1"	15'-6"	16'-8"
440	16'-6"	16'-10"	17'-3"	17'-7"	17'-0"	18'-2"
460	18'-1"	18'-5"	18'-10"	19'-2"	18'-7"	19'-9"
480	19'-8"	20'-1"	20'-6"	20'-10"	20'-3"	21'-5"
500	21'-5"	21'-10"	22'-2"	22'-7"	22'-0"	23'-2"

CO 160

Sag Chart 2/0 and 4/0 Copper

Approved by:



Sheet 4 of 5

What's Changed? Updated sag values for 17 kV rated 4/0 copper covered conductor.

Effective Date:

DOH

01-25-2019

Table CO 160–5: Tension — Temperature Stringing Table 17 kV 4/0 Copper Covered Conductor for Heavy-Loading Areas

Span (ft)	Tension (lb)					
	Initial Stringing Tension				Final Tension	
	50°F	70°F	90°F	110°F	70°F	130°F
100	1,478	1,191	975	820	1,075	658
120	1,433	1,192	1,011	877	1,096	730
140	1,394	1,193	1,040	923	1,113	790
160	1,362	1,194	1,063	961	1,127	841
180	1,335	1,194	1,082	992	1,137	884
200	1,314	1,195	1,098	1,018	1,146	920
220	1,296	1,195	1,111	1,040	1,153	951
240	1,282	1,195	1,121	1,058	1,159	978
260	1,271	1,196	1,130	1,074	1,164	1,001
280	1,262	1,196	1,138	1,087	1,168	1,021
300	1,254	1,196	1,144	1,099	1,171	1,038
320	1,247	1,196	1,150	1,108	1,174	1,053
340	1,242	1,196	1,155	1,117	1,176	1,066
360	1,237	1,196	1,159	1,124	1,178	1,078
380	1,233	1,196	1,162	1,131	1,180	1,088
400	1,230	1,196	1,165	1,137	1,182	1,097
420	1,227	1,197	1,168	1,142	1,183	1,105
440	1,224	1,197	1,171	1,146	1,184	1,112
460	1,222	1,197	1,173	1,150	1,185	1,119
480	1,220	1,197	1,175	1,154	1,186	1,124
500	1,218	1,197	1,176	1,157	1,187	1,130

1.0 Guying

Conductor tensions for guying 4/0 copper covered conductor is 2,780 lb.

2.0 Ground Clearance

Use 130°F sags when calculating conductor-to-ground clearances.

This page intentionally left blank.

CO 162 Sag Chart 1/0 ACSR

Scope CO 162.1 Sag — Temperature Stringing Table 1/0 ACSR for Heavy-Loading Areas

Table CO 162–1: Sag — Temperature Stringing Table 1/0 ACSR for Heavy-Loading Areas

Span (ft)	Sag					
	Initial Stringing Sag				Final Sag	
	50°F	70°F	90°F	110°F	70°F	130°F
100	0'-4"	0'-4"	0'-6"	0'-10"	0'-7"	1'-6"
120	0'-5"	0'-6"	0'-10"	1'-1"	0'-11"	1'-11"
140	0'-7"	0'-10"	1'-2"	1'-7"	1'-5"	2'-5"
160	0'-11"	1'-2"	1'-8"	2'-1"	1'-11"	3'-0"
180	1'-4"	1'-10"	2'-4"	2'-8"	2'-5"	3'-7"
200	1'-11"	2'-5"	2'-11"	3'-5"	3'-1"	4'-4"
220	2'-7"	3'-2"	3'-8"	4'-1"	3'-10"	5'-1"
240	3'-5"	4'-0"	4'-6"	4'-11"	4'-8"	5'-11"
260	4'-4"	4'-11"	5'-4"	5'-10"	5'-6"	6'-10"
280	5'-4"	5'-10"	6'-4"	6'-8"	6'-6"	7'-10"
300	6'-4"	6'-10"	7'-3"	7'-10"	7'-6"	8'-10"
320	7'-5"	7'-11"	8'-5"	8'-11"	8'-7"	9'-11"
340	8'-7"	9'-1"	9'-7"	10'-0"	9'-8"	11'-1"
360	9'-10"	10'-4"	10'-10"	11'-4"	11'-0"	12'-4"
380	11'-1"	11'-7"	12'-1"	12'-7"	12'-4"	13'-7"
400	12'-6"	13'-0"	13'-6"	13'-11"	13'-8"	15'-0"
420	14'-0"	14'-5"	14'-11"	15'-5"	15'-1"	16'-5"
440	15'-6"	16'-0"	16'-5"	16'-11"	16'-7"	17'-11"
460	17'-1"	17'-6"	18'-0"	18'-6"	18'-2"	19'-6"
480	18'-8"	19'-2"	19'-8"	20'-1"	19'-11"	21'-2"
500	20'-6"	20'-11"	21'-5"	21'-11"	21'-7"	22'-11"

1.0 Guying

Conductor tensions for guying is 1,415 lb.

2.0 Ground Clearance

Use 130°F sags when calculating conductor-to-ground clearances.

Approved by: <i>ajf</i>	Sag Chart 1/0 ACSR	CO 162
Effective Date: 01-25-2019	What's Changed?	Sheet 1 of 5
		DOH

Scope CO 162.2 Sag — Temperature Stringing Table 1/0 ACSR Covered Conductor for Heavy-Loading Areas

Table CO 162-2: Sag — Temperature Stringing Table 17 kV 1/0 ACSR Covered Conductor for Heavy-Loading Areas

Span (ft)	Sag					
	Initial Stringing Sag				Final Sag	
	50°F	70°F	90°F	110°F	70°F	130°F
100	0'-6"	0'-7"	0'-9"	0'-11"	0'-11"	1'-5"
120	0'-9"	1'-0"	1'-2"	1'-5"	1'-5"	1'-11"
140	1'-3"	1'-6"	1'-9"	2'-1"	2'-0"	2'-7"
160	1'-10"	2'-2"	2'-6"	2'-9"	2'-9"	3'-4"
180	2'-8"	3'-0"	3'-4"	3'-7"	3'-6"	4'-2"
200	3'-7"	3'-11"	4'-3"	4'-6"	4'-5"	5'-1"
220	4'-7"	4'-11"	5'-3"	5'-6"	5'-6"	6'-2"
240	5'-8"	6'-0"	6'-4"	6'-8"	6'-7"	7'-3"
260	6'-11"	7'-3"	7'-7"	7'-11"	7'-10"	8'-6"
280	8'-3"	8'-7"	8'-11"	9'-2"	9'-2"	9'-10"
300	9'-8"	10'-0"	10'-4"	10'-7"	10'-7"	11'-3"
320	11'-2"	11'-6"	11'-10"	12'-2"	12'-1"	12'-9"
340	12'-10"	13'-2"	13'-5"	13'-9"	13'-8"	14'-5"
360	14'-6"	14'-10"	15'-2"	15'-6"	15'-5"	16'-2"
380	16'-4"	16'-8"	17'-0"	17'-4"	17'-3"	18'-0"
400	18'-3"	18'-7"	18'-11"	19'-3"	19'-2"	19'-11"
420	20'-4"	20'-8"	21'-0"	21'-3"	21'-2"	21'-11"
440	22'-5"	22'-9"	23'-1"	23'-5"	23'-4"	24'-1"
460	24'-8"	25'-0"	25'-4"	25'-8"	25'-7"	26'-4"
480	27'-0"	27'-4"	27'-8"	28'-0"	27'-11"	28'-8"
500	29'-6"	29'-10"	30'-1"	30'-5"	30'-4"	31'-1"

CO 162

Sag Chart 1/0 ACSR

Approved by:

a/j

Sheet 2 of 5

What's Changed? Updated sag values for 17 kV rated 1/0 ACSR covered conductor.

Effective Date:

DOH

01-25-2019

Table CO 162-3: Tension — Temperature Stringing Table 17 kV 1/0 ACSR Covered Conductor for Heavy-Loading Areas

Span (ft)	Tension (lb)					
	Initial Stringing Tension				Final Tension	
	50°F	70°F	90°F	110°F	70°F	130°F
100	755	608	476	373	402	257
120	653	527	426	352	371	263
140	558	463	390	337	350	268
160	485	417	366	327	336	272
180	434	387	349	320	327	276
200	400	366	338	315	320	278
220	377	351	329	311	315	280
240	360	340	323	308	311	282
260	348	332	318	306	308	283
280	339	326	314	304	306	284
300	332	321	311	302	304	285
320	327	318	309	301	303	286
340	322	314	307	300	302	287
360	319	312	305	299	301	287
380	316	310	304	299	300	288
400	313	308	303	298	299	288
420	311	306	302	297	298	289
440	309	305	301	297	298	289
460	308	304	300	297	297	289
480	306	303	300	296	297	289
500	305	302	299	296	297	290

Approved by:

ajf

Sag Chart 1/0 ACSR

CO 162

Sheet 3 of 5

Effective Date:
01-25-2019

What's Changed? Added new tension values for 17 kV rated 1/0 copper covered conductor.

DOH

Table CO 162-4: Sag — Temperature Stringing Table 35 kV 1/0 ACSR Covered Conductor for Heavy-Loading Areas

Span (ft)	Sag					
	Initial Stringing Sag				Final Sag	
	50°F	70°F	90°F	110°F	70°F	130°F
100	0'-10"	1'-0"	1'-3"	1'-5"	1'-4"	1'-10"
120	1'-5"	1'-8"	1'-10"	2'-1"	2'-0"	2'-7"
140	2'-2"	2'-5"	2'-8"	2'-11"	2'-10"	3'-5"
160	3'-1"	3'-4"	3'-7"	3'-10"	3'-9"	4'-4"
180	4'-2"	4'-5"	4'-7"	4'-10"	4'-9"	5'-5"
200	5'-4"	5'-7"	5'-10"	6'-0"	6'-0"	6'-8"
220	6'-7"	6'-10"	7'-1"	7'-4"	7'-3"	7'-11"
240	8'-1"	8'-4"	8'-7"	8'-9"	8'-9"	9'-5"
260	9'-7"	9'-10"	10'-1"	10'-4"	10'-3"	11'-0"
280	11'-4"	11'-7"	11'-10"	12'-1"	12'-0"	12'-8"
300	13'-2"	13'-5"	13'-8"	13'-11"	13'-10"	14'-6"
320	15'-1"	15'-4"	15'-7"	15'-10"	15'-9"	16'-6"
340	17'-2"	17'-5"	17'-8"	17'-11"	17'-10"	18'-7"
360	19'-5"	19'-8"	19'-11"	20'-2"	20'-1"	20'-9"
380	21'-9"	22'-0"	22'-3"	22'-6"	22'-5"	23'-2"
400	24'-3"	24'-6"	24'-9"	25'-0"	24'-11"	25'-8"
420	26'-10"	27'-1"	27'-4"	27'-7"	27'-6"	28'-3"
440	29'-8"	29'-11"	30'-2"	30'-4"	30'-4"	31'-0"
460	32'-6"	32'-9"	33'-0"	33'-3"	33'-2"	33'-11"
480	35'-7"	35'-10"	36'-1"	36'-4"	36'-3"	37'-0"
500	38'-9"	39'-0"	39'-3"	39'-6"	39'-5"	40'-2"

CO 162

Sag Chart 1/0 ACSR

Approved by:

a/j

Sheet 4 of 5

What's Changed? Added new sag values for 35 kV rated 1/0 ACSR covered conductor.

Effective Date:

DOH

01-25-2019

Table CO 162-5: Tension — Temperature Stringing Table 35 kV 1/0 ACSR Covered Conductor for Heavy-Loading Areas

Span (ft)	Tension (lb)					
	Initial Stringing Tension				Final Tension	
	50°F	70°F	90°F	110°F	70°F	130°F
100	664	558	474	409	429	313
120	576	503	445	399	413	324
140	516	466	426	392	402	333
160	477	442	413	388	395	339
180	452	426	404	384	390	344
200	435	415	398	382	387	349
220	422	407	393	380	384	352
240	413	401	389	379	382	355
260	407	396	387	378	380	357
280	401	393	385	377	379	358
300	397	390	383	376	378	360
320	394	387	381	376	377	361
340	391	385	380	375	377	362
360	389	384	379	375	376	363
380	387	382	378	374	375	364
400	385	381	378	374	375	365
420	384	380	377	374	375	365
440	383	379	376	374	374	366
460	382	379	376	373	374	366
480	381	378	376	373	374	367
500	380	378	375	373	374	367

1.0 Guying

Conductor tensions for guying 1/0 Covered Conductor is 1,415 lb.

2.0 Ground Clearance

Use 130°F sags when calculating conductor-to-ground clearances.

This page intentionally left blank.

CO 164 Sag Chart 336 ACSR

Scope CO 164.1 Sag — Temperature Stringing Area 336 ACSR for Heavy-Loading Areas

Table CO 164–1: Sag — Temperature Stringing Area 336 ACSR for Heavy-Loading Areas

Span (ft)	Sag					
	Initial Stringing Sag				Final Sag	
	50°F	70°F	90°F	110°F	70°F	130°F
100	0'-4"	0'-6"	0'-10"	1'-2"	0'-11"	1'-10"
120	0'-6"	0'-8"	1'-1"	1'-6"	1'-2"	2'-2"
140	0'-8"	1'-0"	1'-5"	1'-11"	1'-7"	2'-8"
160	0'-11"	1'-4"	1'-10"	2'-4"	1'-11"	3'-2"
180	1'-2"	1'-8"	2'-4"	2'-8"	2'-5"	3'-8"
200	1'-7"	2'-2"	2'-8"	3'-2"	2'-11"	4'-2"
220	2'-1"	2'-8"	3'-4"	3'-10"	3'-5"	4'-10"
240	2'-7"	3'-2"	3'-10"	4'-5"	4'-0"	5'-6"
260	3'-2"	3'-10"	4'-6"	5'-0"	4'-7"	6'-2"
280	3'-10"	4'-6"	5'-1"	5'-8"	5'-4"	6'-11"
300	4'-6"	5'-2"	5'-10"	6'-5"	6'-0"	7'-8"
320	5'-4"	6'-0"	6'-7"	7'-2"	6'-10"	8'-6"
340	6'-1"	6'-10"	7'-5"	8'-0"	7'-7"	9'-4"
360	6'-11"	7'-7"	8'-3"	8'-11"	8'-6"	10'-2"
380	7'-10"	8'-5"	9'-2"	9'-10"	9'-5"	11'-2"
400	8'-10"	9'-6"	10'-2"	10'-10"	10'-4"	12'-2"
420	9'-10"	10'-6"	11'-2"	11'-10"	11'-5"	13'-2"
440	10'-10"	11'-7"	12'-2"	12'-11"	12'-5"	14'-4"
460	11'-11"	12'-8"	13'-5"	14'-0"	13'-6"	15'-5"
480	13'-1"	13'-10"	14'-6"	15'-2"	14'-8"	16'-7"
500	14'-4"	15'-0"	15'-8"	16'-4"	15'-11"	17'-10"

1.0 Guying

Conductor tensions for guying is 2,846 lb.

2.0 Ground Clearance

Use 130°F sags when calculating conductor-to-ground clearances.

Approved by: 	Sag Chart 336 ACSR	CO 164
Effective Date: 01-25-2019	What's Changed?	Sheet 1 of 5
		DOH

Scope CO 164.2 Sag — Temperature Stringing Table 336 ACSR Covered Conductor for Heavy-Loading Areas

Table CO 164–2: Sag — Temperature Stringing Table 17 kV 336 ACSR Covered Conductor for Heavy-Loading Areas

Span (ft)	Sag					
	Initial Stringing Sag				Final Sag	
	50°F	70°F	90°F	110°F	70°F	130°F
100	0'-6"	0'-8"	0'-11"	1'-2"	1'-0"	1'-9"
120	0'-8"	0'-11"	1'-3"	1'-7"	1'-4"	2'-3"
140	1'-0"	1'-4"	1'-8"	2'-1"	1'-9"	2'-9"
160	1'-5"	1'-9"	2'-2"	2'-7"	2'-3"	3'-4"
180	1'-11"	2'-4"	2'-9"	3'-2"	2'-10"	3'-11"
200	2'-6"	2'-11"	3'-4"	3'-9"	3'-5"	4'-8"
220	3'-1"	3'-7"	4'-1"	4'-6"	4'-2"	5'-4"
240	3'-10"	4'-4"	4'-10"	5'-3"	4'-11"	6'-2"
260	4'-7"	5'-2"	5'-7"	6'-1"	5'-9"	7'-0"
280	5'-6"	6'-0"	6'-6"	7'-0"	6'-7"	7'-11"
300	6'-5"	6'-11"	7'-5"	7'-11"	7'-6"	8'-11"
320	7'-5"	7'-11"	8'-5"	8'-11"	8'-6"	9'-11"
340	8'-6"	9'-0"	9'-6"	10'-0"	9'-7"	11'-0"
360	9'-7"	10'-2"	10'-8"	11'-2"	10'-9"	12'-2"
380	10'-9"	11'-4"	11'-10"	12'-4"	11'-11"	13'-5"
400	12'-1"	12'-7"	13'-1"	13'-7"	13'-3"	14'-8"
420	13'-5"	13'-11"	14'-5"	15'-0"	14'-7"	16'-0"
440	14'-9"	15'-4"	15'-10"	16'-4"	16'-0"	17'-5"
460	16'-3"	16'-9"	17'-4"	17'-10"	17'-5"	18'-11"
480	17'-9"	18'-4"	18'-10"	19'-5"	19'-0"	20'-6"
500	19'-5"	19'-11"	20'-6"	21'-0"	20'-7"	22'-1"

CO 164

Sag Chart 336 ACSR

Approved by:



Sheet 2 of 5

What's Changed? Updated sag values for 17 kV rated 336 ACSR covered conductor.

Effective Date:

DOH

01-25-2019

Table CO 164–3: Tension — Temperature Stringing Table 17 kV 336 ACSR Covered Conductor for Heavy-Loading Areas

Span (ft)	Tension (lb)					
	Initial Stringing Tension				Final Tension	
	50°F	70°F	90°F	110°F	70°F	130°F
100	1573	1132	802	605	752	408
120	1477	1090	818	650	776	463
140	1383	1055	831	687	796	512
160	1297	1026	841	716	811	554
180	1225	1003	849	740	823	590
200	1166	985	855	760	833	622
220	1119	970	860	777	841	650
240	1083	959	864	790	848	674
260	1054	949	868	802	853	695
280	1030	942	870	812	858	714
300	1012	936	873	820	862	730
320	997	930	875	828	865	744
340	984	926	877	834	867	757
360	974	922	878	839	870	768
380	965	919	879	844	872	778
400	957	917	880	848	874	787
420	951	914	881	852	875	795
440	945	912	882	855	876	802
460	941	910	883	858	878	809
480	936	909	884	860	879	815
500	933	907	884	863	880	820

Approved by:

ajf

Sag Chart 336 ACSR

CO 164

Effective Date:
01-25-2019

What's Changed? Added new tension values for 17 kV rated 336 ACSR covered conductor.

Sheet 3 of 5

DOH

Table CO 164-4: Sag — Temperature Stringing Table 35 kV 336 ACSR Covered Conductor for Heavy-Loading Areas

Span (ft)	Sag					
	Initial Stringing Sag				Final Sag	
	50°F	70°F	90°F	110°F	70°F	130°F
100	0'-8"	0'-10"	1'-1"	1'-4"	1'-2"	1'-11"
120	1'-0"	1'-3"	1'-7"	1'-10"	1'-8"	2'-5"
140	1'-5"	1'-9"	2'-1"	2'-5"	2'-2"	3'-1"
160	2'-0"	2'-4"	2'-8"	3'-0"	2'-9"	3'-9"
180	2'-7"	3'-0"	3'-4"	3'-9"	3'-6"	4'-6"
200	3'-4"	3'-9"	4'-1"	4'-6"	4'-3"	5'-3"
220	4'-2"	4'-7"	5'-0"	5'-4"	5'-1"	6'-2"
240	5'-1"	5'-6"	5'-11"	6'-3"	6'-0"	7'-1"
260	6'-1"	6'-6"	6'-11"	7'-3"	7'-0"	8'-2"
280	7'-2"	7'-7"	8'-0"	8'-4"	8'-1"	9'-3"
300	8'-3"	8'-9"	9'-2"	9'-6"	9'-3"	10'-5"
320	9'-6"	10'-0"	10'-5"	10'-9"	10'-6"	11'-8"
340	10'-10"	11'-3"	11'-9"	12'-1"	11'-10"	13'-0"
360	12'-3"	12'-8"	13'-1"	13'-6"	13'-3"	14'-6"
380	13'-9"	14'-2"	14'-7"	15'-0"	14'-9"	16'-0"
400	15'-4"	15'-9"	16'-2"	16'-7"	16'-4"	17'-7"
420	17'-0"	17'-5"	17'-10"	18'-3"	18'-0"	19'-3"
440	18'-8"	19'-2"	19'-7"	20'-0"	19'-9"	21'-0"
460	20'-6"	21'-0"	21'-5"	21'-10"	21'-7"	22'-10"
480	22'-5"	22'-10"	23'-4"	23'-9"	23'-6"	24'-9"
500	24'-5"	24'-10"	25'-3"	25'-9"	25'-5"	26'-9"

CO 164

Sag Chart 336 ACSR

Approved by:



Sheet 4 of 5

What's Changed? Added new sag values for 35 kV rated 336 ACSR covered conductor.

Effective Date:

DOH

01-25-2019

Table CO 164–5: Tension — Temperature Stringing Table 35 kV 336 ACSR Covered Conductor for Heavy-Loading Areas

Span (ft)	Tension					
	Initial Stringing Tension				Final Tension	
	50°F	70°F	90°F	110°F	70°F	130°F
100	1555	1184	916	741	853	529
120	1457	1153	937	790	883	594
140	1371	1127	952	828	906	648
160	1300	1106	963	858	924	694
180	1245	1090	972	881	938	733
200	1202	1077	978	900	949	766
220	1170	1066	983	915	958	794
240	1144	1058	987	928	965	818
260	1124	1052	990	938	971	839
280	1108	1046	993	947	976	857
300	1095	1042	995	954	980	872
320	1085	1038	997	960	983	885
340	1076	1035	998	965	986	897
360	1069	1033	1000	969	988	907
380	1063	1030	1001	973	990	916
400	1057	1028	1002	977	992	924
420	1053	1027	1002	980	994	931
440	1049	1025	1003	982	995	937
460	1046	1024	1004	985	997	943
480	1043	1023	1004	987	998	948
500	1040	1022	1005	988	999	953

1.0 Guying

Conductor tensions for guying 336.4 Covered Conductor is 2,846 lb.

2.0 Ground Clearance

Use 130°F sags when calculating conductor-to-ground clearances.

This page intentionally left blank.

CO 166 Sag Chart 654 ACSR

Scope CO 166.1 Sag — Temperature Stringing Table 654 ACSR for Heavy-Loading Areas

Table CO 166–1: Sag — Temperature Stringing Table 654 ACSR for Heavy-Loading Areas

Span (ft)	Sag					
	Initial Stringing Sag				Final Sag	
	50°F	70°F	90°F	110°F	70°F	130°F
100	0'-8"	1'-1"	1'-5"	1'-8"	1'-6"	2'-2"
120	1'-0"	1'-5"	1'-10"	2'-1"	1'-11"	2'-8"
140	1'-5"	1'-10"	2'-2"	2'-7"	2'-4"	3'-2"
160	1'-10"	2'-4"	2'-9"	3'-1"	2'-10"	3'-10"
180	2'-4"	2'-10"	3'-2"	3'-7"	3'-4"	4'-5"
200	2'-10"	3'-4"	3'-10"	4'-2"	3'-11"	5'-1"
220	3'-5"	4'-0"	4'-6"	4'-11"	4'-7"	5'-10"
240	4'-1"	4'-7"	5'-1"	5'-7"	5'-4"	6'-6"
260	4'-10"	5'-5"	5'-11"	6'-5"	6'-0"	7'-4"
280	5'-7"	6'-2"	6'-8"	7'-2"	6'-10"	8'-2"
300	6'-5"	7'-0"	7'-6"	8'-0"	7'-8"	9'-1"
320	7'-4"	7'-11"	8'-6"	9'-0"	8'-7"	10'-0"
340	8'-4"	8'-11"	9'-5"	9'-11"	9'-6"	11'-0"
360	9'-4"	9'-11"	10'-5"	11'-0"	10'-7"	12'-1"
380	10'-5"	11'-0"	11'-6"	12'-1"	11'-7"	13'-2"
400	11'-6"	12'-1"	12'-8"	13'-2"	12'-10"	14'-5"
420	12'-8"	13'-4"	13'-10"	14'-5"	14'-0"	15'-7"
440	13'-11"	14'-6"	15'-1"	15'-8"	15'-2"	16'-10"
460	15'-2"	15'-10"	16'-5"	17'-0"	16'-6"	18'-2"
480	16'-7"	17'-2"	17'-10"	18'-4"	17'-11"	19'-7"
500	18'-0"	18'-7"	19'-2"	19'-10"	19'-4"	21'-0"

1.0 Guying

Conductor tensions for guying is 3,267 lb.

2.0 Ground Clearance

Use 130°F sags when calculating conductor-to-ground clearances.

Approved by: <i>ajf</i>	Sag Chart 654 ACSR	CO 166
Effective Date: 01-25-2019	What's Changed?	Sheet 1 of 5
		DOH

Scope CO 166.2 Sag — Temperature Stringing Table 654 ACSR Covered Conductor for Heavy-Loading Areas

Table CO 166–2: Sag — Temperature Stringing Table 17 kV 654 ACSR Covered Conductor for Heavy-Loading Areas

Span (ft)	Sag					
	Initial Stringing Sag				Final Sag	
	50°F	70°F	90°F	110°F	70°F	130°F
100	1'-0"	1'-3"	1'-7"	1'-9"	1'-6"	2'-1"
120	1'-5"	1'-8"	2'-0"	2'-3"	2'-0"	2'-8"
140	1'-10"	2'-2"	2'-6"	2'-10"	2'-6"	3'-4"
160	2'-4"	2'-9"	3'-1"	3'-5"	3'-1"	4'-0"
180	3'-0"	3'-4"	3'-9"	4'-1"	3'-9"	4'-9"
200	3'-8"	4'-1"	4'-5"	4'-10"	4'-6"	5'-6"
220	4'-5"	4'-10"	5'-3"	5'-7"	5'-3"	6'-4"
240	5'-3"	5'-8"	6'-1"	6'-6"	6'-2"	7'-3"
260	6'-2"	6'-7"	7'-0"	7'-5"	7'-1"	8'-3"
280	7'-2"	7'-7"	8'-0"	8'-5"	8'-1"	9'-3"
300	8'-3"	8'-8"	9'-1"	9'-6"	9'-2"	10'-5"
320	9'-5"	9'-10"	10'-3"	10'-8"	10'-4"	11'-7"
340	10'-7"	11'-1"	11'-6"	11'-11"	11'-7"	12'-10"
360	11'-8"	12'-2"	12'-4"	12'-10"	12'-8"	13'-9"
380	13'-1"	13'-6"	13'-9"	14'-2"	14'-0"	15'-2"
400	14'-6"	15'-0"	15'-2"	15'-8"	15'-6"	16'-7"
420	16'-0"	16'-6"	16'-9"	17'-2"	17'-0"	18'-2"
440	17'-8"	18'-1"	18'-4"	18'-9"	18'-8"	19'-9"
460	19'-4"	19'-9"	20'-0"	20'-5"	20'-4"	21'-6"
480	21'-1"	21'-6"	21'-9"	22'-3"	22'-1"	23'-3"
500	22'-11"	23'-4"	23'-7"	24'-1"	23'-11"	25'-1"

CO 166

Sag Chart 654 ACSR

Approved by:



Sheet 2 of 5

What's Changed? Updated sag values for 17 kV rated 653 ACSR covered conductor.

Effective Date:

DOH

01-25-2019

Table CO 166-3: Tension — Temperature Stringing Table 17 kV 654 ACSR Covered Conductor for Heavy-Loading Areas

Span (ft)	Tension (lb)					
	Initial Stringing Tension				Final Tension	
	50°F	70°F	90°F	110°F	70°F	130°F
100	1,229	954	791	685	818	596
120	1,275	1,036	883	778	898	664
140	1,303	1,097	957	856	963	723
160	1,319	1,142	1,016	921	1,016	782
180	1,328	1,177	1,063	975	1,059	839
200	1,333	1,203	1,101	1,021	1,095	890
220	1,336	1,223	1,132	1,058	1,124	934
240	1,337	1,239	1,158	1,090	1,149	972
260	1,337	1,251	1,179	1,117	1,169	1,006
280	1,337	1,261	1,196	1,140	1,187	1,036
300	1,337	1,270	1,211	1,160	1,202	1,063
320	1,336	1,276	1,224	1,176	1,214	1,086
340	1,336	1,282	1,234	1,191	1,225	1,106
360	3,354	1,310	1,287	1,243	1,257	1,158
380	3,346	1,312	1,291	1,251	1,263	1,172
400	3,340	1,314	1,294	1,258	1,268	1,185
420	3,334	1,315	1,297	1,264	1,273	1,196
440	3,329	1,316	1,300	1,269	1,278	1,206
460	3,324	1,317	1,302	1,274	1,282	1,215
480	3,320	1,318	1,304	1,278	1,285	1,223
500	3,316	1,318	1,306	1,281	1,288	1,230

Approved by:
a/j

Effective Date:
01-25-2019

Sag Chart 654 ACSR

What's Changed? Added new tension values for 17 kV rated 653 ACSR covered conductor.

CO 166

Sheet 3 of 5

DOH

Table CO 166-4: Sag — Temperature Stringing Table 35 kV 654 ACSR Covered Conductor for Heavy-Loading Areas

Span (ft)	Sag					
	Initial Stringing Sag				Final Sag	
	50°F	70°F	90°F	110°F	70°F	130°F
100	1'-2"	1'-5"	1'-8"	1'-11"	1'-8"	2'-3"
120	1'-7"	1'-11"	2'-2"	2'-5"	2'-2"	2'-11"
140	2'-2"	2'-6"	2'-9"	3'-0"	2'-9"	3'-7"
160	2'-9"	3'-1"	3'-5"	3'-9"	3'-6"	4'-4"
180	3'-6"	3'-10"	4'-2"	4'-6"	4'-3"	5'-2"
200	4'-4"	4'-8"	5'-0"	5'-4"	5'-1"	6'-0"
220	5'-3"	5'-7"	6'-0"	6'-3"	6'-0"	7'-0"
240	6'-3"	6'-8"	7'-0"	7'-4"	7'-1"	8'-1"
260	7'-4"	7'-9"	8'-1"	8'-5"	8'-2"	9'-3"
280	8'-6"	8'-11"	9'-3"	9'-8"	9'-5"	10'-5"
300	9'-10"	10'-2"	10'-7"	10'-11"	10'-8"	11'-9"
320	11'-2"	11'-7"	11'-11"	12'-4"	12'-1"	13'-2"
340	12'-8"	13'-0"	13'-5"	13'-9"	13'-6"	14'-7"
360	14'-2"	14'-7"	14'-11"	15'-4"	15'-1"	16'-2"
380	15'-10"	16'-3"	16'-7"	17'-0"	16'-9"	17'-10"
400	17'-7"	17'-11"	18'-4"	18'-8"	18'-6"	19'-7"
420	19'-5"	19'-9"	20'-2"	20'-6"	20'-3"	21'-5"
440	21'-4"	21'-8"	22'-1"	22'-5"	22'-3"	23'-4"
460	23'-4"	23'-8"	24'-1"	24'-6"	24'-3"	25'-5"
480	25'-5"	25'-10"	26'-2"	26'-7"	26'-4"	27'-6"
500	27'-7"	28'-0"	28'-5"	28'-9"	28'-6"	29'-8"

CO 166

Sheet 4 of 5

DOH

Sag Chart 654 ACSR

What's Changed? Added new sag values for 35 kV rated 653 ACSR covered conductor.

Approved by:

ajf

Effective Date:

01-25-2019

Table CO 166–5: Tension — Temperature Stringing Table 35 kV 654 ACSR Covered Conductor for Heavy-Loading Areas

Span (ft)	Tension (lb)					
	Initial Stringing Tension				Final Tension	
	50°F	70°F	90°F	110°F	70°F	130°F
100	1,358	1,105	942	829	949	698
120	1,395	1,182	1,035	928	1,031	774
140	1,414	1,236	1,106	1,007	1,096	854
160	1,424	1,275	1,161	1,071	1,147	923
180	1,429	1,304	1,204	1,123	1,188	982
200	1,431	1,325	1,238	1,165	1,221	1,033
220	1,432	1,341	1,264	1,199	1,248	1,076
240	1,432	1,353	1,286	1,227	1,270	1,114
260	1,431	1,363	1,303	1,250	1,288	1,146
280	1,430	1,371	1,318	1,270	1,303	1,174
300	1,429	1,377	1,330	1,287	1,316	1,198
320	1,428	1,382	1,340	1,301	1,327	1,219
340	1,428	1,386	1,348	1,313	1,336	1,237
360	1,427	1,390	1,355	1,323	1,344	1,253
380	1,426	1,393	1,361	1,332	1,351	1,268
400	1,425	1,395	1,367	1,340	1,357	1,280
420	1,425	1,397	1,371	1,347	1,363	1,291
440	1,424	1,399	1,375	1,353	1,367	1,301
460	1,424	1,401	1,379	1,358	1,371	1,310
480	1,423	1,402	1,382	1,363	1,375	1,318
500	1,423	1,404	1,385	1,367	1,378	1,325

1.0 Guying

Conductor tensions for guying 653.9 Covered Conductor is 3,267 lb.

2.0 Ground Clearance

Use 130°F sags when calculating conductor-to-ground clearances.

This page intentionally left blank.

CO 168 Reduce Tension Span Sag Charts — Directions for Use

Scope CO 168.1 Directions for Use of Sag Charts

Unguyed (or Slack) Spans may be considered when the use of downguys or span guys is not feasible. The resultant (bending) moment created by the unguyed strain must be equaled or exceeded by the usable pole strength. A breast block and pole key (PO Section) must be installed on all unguyed dead-end and angle poles.

Reduced tension unguyed spans where the resultant moment exceeds either the usable pole strength or the pole key resisting moment based on the soil condition, the strain should be guyed or the resultant moment reduced. The moment may be reduced by reducing the height of the conductors while maintaining General Order 95 (G.O. 95) clearances.

Reduced tension guyed spans may be considered when a full tension down guy lead is not feasible (that is, easement issue, obstruction).

Reduced tension Span Tensions have been determined by engineering in the following Tension Table and Figures. [Table CO 168–36](#) and [Table CO 168–40](#) are used to illustrate and document the values used in SPIDA. Only commonly used conductors and sizes are represented in the tables as examples, though all conductors and sizes are in SPIDA.

Figure CO 168–1: Reduced Tension Unguyed Span Example

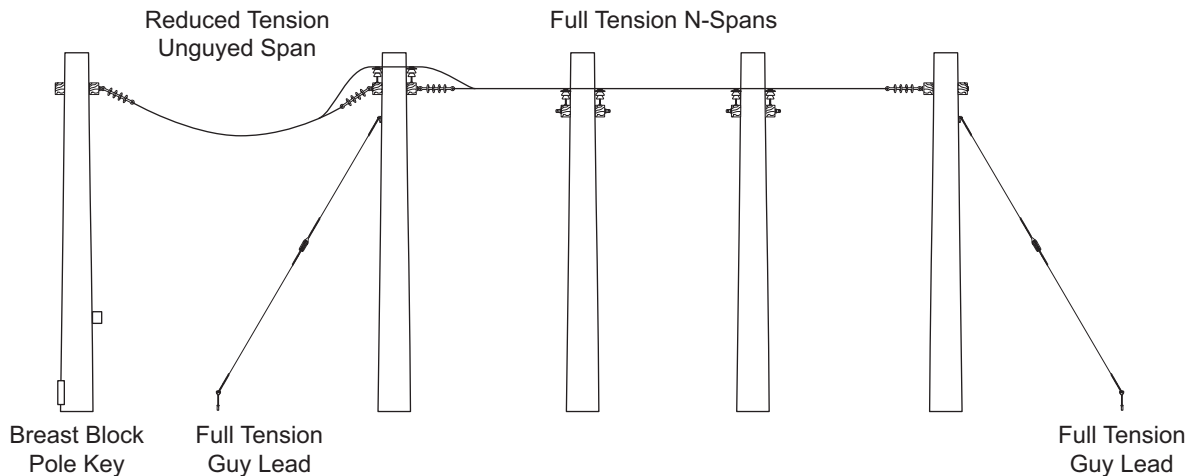

Approved by:
ajf

Effective Date:
01-25-2019

Reduce Tension Span Sag Charts — Directions for Use

What's Changed?

CO 168

Sheet 1 of 80

DOH

Figure CO 168–2: Reduced Tension Guyed Span Example

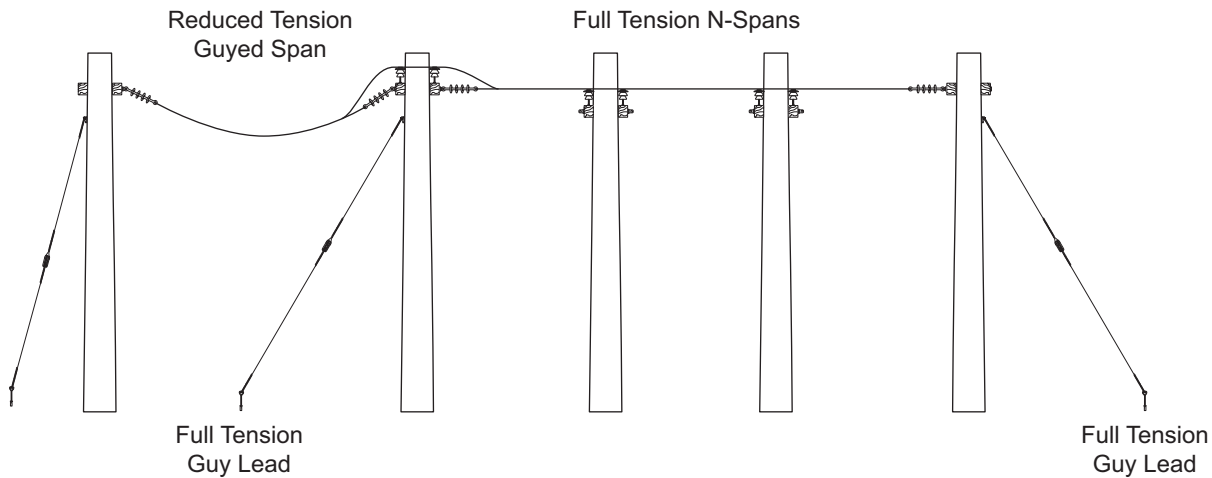

Table CO 168–1: Percent Full Tension of Conductor Light-Loading Areas

Bare ACSR Conductor			
	0–120 feet	121–160 feet	161–200 feet
Guyed new and existing	20%	20%	20%
Unguyed existing ^{a/}	10%	10%	— ^{b/}
Unguyed new	10%	N/A	N/A
Bare Copper Conductor			
	0–120 feet	121–160 feet	161–200 feet
Guyed new and existing	15%	30%	30%
Unguyed existing ^{b/}	15%	30%	— ^{b/}
Unguyed new	15%	N/A	N/A
ACSR MultiPlex Conductor			
	0–120 feet	121–160 feet	161–200 feet
Guyed new and existing	50%	50%	— ^{c/}
Unguyed existing ^{b/}	25%	50%	— ^{c/}
Unguyed new	25%	N/A	N/A

^{a/} This includes existing construction that requires rebuilding or pole replacement. When practicable, consider adding a guy (reduced tension) to the pole or additional poles to reduce span lengths.

^{b/} Unguyed existing and rebuild spans for all conductor sizes exceeding 160 feet shall be guyed and considered reduced tension guyed spans.

^{c/} All multiplex conductor sizes exceeding 160 feet shall be full tension and guyed.

Note(s):

1. This table applies to reduced tension guyed and reduced tension unguyed spans. See [Figure CO 168–1](#) and [Figure CO 168–2](#), other design configurations may apply.
2. ACSR and Copper Covered Conductors are not included in [Table CO 168–1](#) because their reduced sags are calculated through a different method, making the information given in [Table CO 168–1](#) not applicable.

Table CO 168–2: Percent Full Tension of Conductor Heavy — Loading Areas

Bare ACSR Conductor			
	Size	0–120 feet	121–160 feet
Guyed new and existing	#4 – 1/0	50%	50%
	336 – 653	25%	25%
Unguyed existing ^{a/}	#4 – 1/0	50%	50%
	336 – 653	25%	25%
Unguyed new	#4 – 1/0	50%	N/A
	336 – 653	25%	N/A
Bare Copper Conductor			
	Size	0–120 feet	121–160 feet
Guyed new and existing	#6 – #2	70%	70%
	2/0	40%	40%
	4/0	30%	30%
Unguyed existing ^{a/}	#6 – #2	70%	70%
	2/0	40%	40%
	4/0	30%	30%
Unguyed new	#6 – #2	70%	N/A
	2/0	40%	N/A
	4/0	30%	N/A
Aluminum Duplex (AD) and Aluminum Triplex (AT) Conductor			
	Size	0–120 feet	121–160 feet
Guyed new and existing	#6 AD – #2 AT	75%	75%
	1/0 AT	50%	50%
	4/0 AT	30%	30%
Unguyed existing and rebuild ^{a/}	#6 AD – #2 AT	75%	75%
	1/0 AT	50%	50%
	4/0 AT	30%	30%
Unguyed new	#6 AD – #2 AT	75%	N/A
	1/0 AT	50%	N/A
	4/0 AT	30%	N/A
Aluminum Quadruplex (AQ) Conductor			
	Size	0–120 feet	121–160 feet
Guyed new and existing	#4	75%	75%
	1/0	50%	50%
	4/0	30%	30%
Unguyed existing ^{a/}	#4	75%	75%
	1/0	50%	50%
	4/0	30%	30%
Unguyed new	#4	75%	N/A
	1/0	50%	N/A
	4/0	30%	N/A

^{a/} This includes existing construction that requires rebuilding or pole replacement. When practicable, consider adding a guy (reduced tension) to the pole or additional poles to reduce span lengths.

Note(s):

1. This table applies to reduced tension guyed and reduced tension unguyed spans. See [Figure CO 168–1](#) and [Figure CO 168–2](#), other design configurations may apply.
2. ACSR and Copper Covered Conductors are not included in [Table CO 168–2](#) because their reduced sags are calculated through a different method, making the information given in [Table CO 168–2](#) not applicable.

Scope CO 168.2 Sag Chart for New and Existing Reduced Tension Guyed Primary #4 — 653 ACSR for Light-Loading Areas

Table CO 168–3: Sag Chart for New and Existing Reduced Tension Guyed Primary #4 — 653 ACSR for Light-Loading Areas

Conductor Type	Span (ft)	Initial Sag	Final Sag
		50–110°F	130°F
#4 ACSR ^{a/}	60	1'-0"	1'-2"
	80	1'-6"	1'-7"
	100	2'-0"	2'-6"
	120	3'-0"	3'-4"
	140	4'-0"	4'-1"
	160	5'-0"	5'-4"
	180	6'-0"	6'-6"
	200	7'-6"	8'-0"
1/0 ACSR	60	1'-0"	1'-2"
	80	1'-6"	1'-7"
	100	2'-0"	2'-6"
	120	2'-6"	2'-8"
	140	3'-0"	3'-6"
	160	3'-6"	4'-3"
	180	4'-6"	5'-4"
	200	5'-6"	6'-4"
336 ACSR	60	1'-0"	1'-2"
	80	1'-6"	1'-7"
	100	2'-0"	2'-6"
	120	2'-6"	2'-8"
	140	3'-0"	3'-6"
	160	3'-6"	4'-3"
	180	4'-6"	5'-4"
	200	5'-6"	6'-4"
653 ACSR	60	1'-0"	1'-2"
	80	1'-6"	2'-0"
	100	2'-0"	2'-6"
	120	3'-0"	3'-6"
	140	4'-0"	4'-6"
	160	5'-0"	5'-6"
	180	6'-0"	6'-8"
	200	7'-6"	8'-4"

^{a/} Not approved for new construction.

Note(s):

- Use on all 2.4 kV through 33 kV systems. 36-inch minimum mid span conductor spacing depending on deviation angle may require more than 36-inch pin spacing to achieve 36-inch conductor spacing.

1.0 Guyed Span Tensions

1.1 Conductor Tensions for Guying are 20 Percent of Full Tension for 0 to 200 Feet

- Conductor tension for guying #4 ACSR is 120 lb
- Conductor tension for guying 1/0 ACSR is 285 lb
- Conductor tension for guying 336 ACSR is 570 lb
- Conductor tension for guying 653 ACSR is 653 lb

2.0 Ground Clearance

Per G.O. 95, use 130°F sags when calculating conductor-to-ground clearances.

Approved by: 	Reduce Tension Span Sag Charts — Directions for Use	CO 168
Effective Date: 01-25-2019	What's Changed?	Sheet 5 of 80 DOH

Scope CO 168.3 Sag Chart for New and Existing Reduced Tension Guyed Primary 1/0 — 653 ACSR Covered Conductor for Light-Loading Areas

Table CO 168-4: Sag Chart for New and Existing Reduced Tension Guyed Primary 17 kV 1/0 — 653 ACSR Covered Conductors for Light-Loading Areas

Conductor Type	Span (ft)	Initial Sag	Final Sag
		50–110°F	130°F
1/0 ACSR	50	2'-0"	2'-1"
	75	3'-0"	3'-2"
	100	3'-5"	3'-9"
	125	4'-4"	4'-9"
	150	5'-2"	5'-8"
	175	6'-0"	6'-7"
	200	6'-9"	7'-7"
336 ACSR	50	2'-0"	2'-1"
	75	3'-0"	3'-2"
	100	3'-6"	3'-10"
	125	4'-4"	4'-10"
	150	5'-2"	5'-10"
	175	6'-0"	6'-10"
	200	6'-10"	7'-10"
653 ACSR	50	2'-0"	2'-2"
	75	3'-0"	3'-3"
	100	3'-6"	3'-10"
	125	4'-4"	4'-10"
	150	5'-2"	5'-10"
	175	6'-0"	6'-10"
	200	6'-10"	7'-10"

Note(s):

1. Use on all 2.4 kV through 17 kV systems. 36-inch minimum mid span conductor spacing depending on deviation angle may require more than 36-inch pin spacing to achieve 36-inch conductor spacing.

CO 168

Reduce Tension Span Sag Charts — Directions for Use

Approved by:



Sheet 6 of 80

What's Changed? Updated sag chart for new and existing reduced tension guyed primary 17 kV 1/0 — 653 ACSR Covered Conductor in Light-Loading Areas.

Effective Date:

01-25-2019

DOH

Table CO 168–5: Tension Table for New and Existing Reduced Tension Guyed Primary 17 kV 1/0 — 653 ACSR Covered Conductors for Light-Loading Areas

Conductor Type	Span (ft)	Initial Tension	Final Tension (lb)
		50–110°F	130°F
1/0 ACSR	50	45	43
	75	68	64
	100	104	95
	125	130	118
	150	156	142
	175	183	165
	200	210	189
336 ACSR	50	91	86
	75	136	127
	100	208	188
	125	261	232
	150	314	277
	175	367	323
	200	420	370
653 ACSR	50	154	144
	75	231	215
	100	353	320
	125	443	397
	150	533	474
	175	624	549
	200	715	626

Approved by:



Reduce Tension Span Sag Charts — Directions for Use

CO 168

Effective Date:
01-25-2019

What's Changed? Added new tension chart for new and existing reduced tension guyed primary 17 kV 1/0 — 653 ACSR Covered Conductor in Light-Loading Areas.

Sheet 7 of 80

DOH

Table CO 168–6: Sag Chart for New and Existing Reduced Tension Guyed Primary 35 kV 1/0 — 653 ACSR Covered Conductors for Light-Loading Areas

Conductor Type	Span (ft)	Initial Sag	Final Sag
		50–110°F	130°F
1/0 ACSR	50	2'-0"	2'-1"
	75	3'-0"	3'-2"
	100	3'-5"	3'-10"
	125	4'-3"	4'-9"
	150	5'-1"	5'-9"
	175	5'-11"	6'-8"
	200	6'-9"	7'-8"
336 ACSR	50	2'-0"	2'-2"
	75	3'-0"	3'-3"
	100	3'-6"	3'-11"
	125	4'-4"	4'-11"
	150	5'-2"	5'-10"
	175	5'-10"	6'-8"
	200	6'-8"	7'-7"
653 ACSR	50	2'-0"	2'-2"
	75	3'-0"	3'-3"
	100	3'-6"	3'-10"
	125	4'-4"	4'-10"
	150	5'-2"	5'-11"
	175	6'-0"	6'-10"
	200	6'-10"	7'-10"

CO 168

Reduce Tension Span Sag Charts — Directions for Use

Approved by:



Sheet 8 of 80

What's Changed? Added new sag chart for new and existing reduced tension guyed primary 35 kV 1/0 — 653 ACSR Covered Conductor in Light-Loading Areas.

Effective Date:

01-25-2019

DOH

Table CO 168–7: Tension Table for New and Existing Reduced Tension Guyed Primary 35 kV 1/0 — 653 ACSR Covered Conductors for Light-Loading Areas

Conductor Type	Span (ft)	Initial Tension	Final Tension (lb)
		50–110°F	130°F
1/0 ACSR	50	73	69
	75	110	102
	100	168	152
	125	211	190
	150	255	227
	175	299	265
	200	344	302
336 ACSR	50	127	119
	75	191	177
	100	292	259
	125	367	323
	150	442	388
	175	527	466
	200	605	533
653 ACSR	50	195	183
	75	294	273
	100	450	404
	125	565	501
	150	681	597
	175	798	697
	200	916	797

Approved by:

a/j

Reduce Tension Span Sag Charts — Directions for Use

CO 168

Sheet 9 of 80

Effective Date:
01-25-2019

What's Changed? Added new tension chart for new and existing reduced tension guyed primary 35 kV 1/0 — 653 ACSR Covered Conductor in Light-Loading Areas.

DOH

1.0 Guyed Span Tensions

Table CO 168–8: Guyed Span Tensions: 17 kV 1/0 — 653 ACSR Covered Conductor for Light-Loading Areas

Conductor Type	Span (ft)	Tension (lb)
1/0 ACSR	50	94
	75	140
	100	215
	125	267
	150	320
	175	371
	200	423
336 ACSR	50	148
	75	222
	100	342
	125	426
	150	511
	175	594
	200	678
653 ACSR	50	218
	75	326
	100	504
	125	629
	150	754
	175	878
	200	1002

Table CO 168–9: Guyed Span Tensions: 35 kV 1/0 — 653 ACSR Covered Conductor for Light-Loading Areas

Conductor Type	Span (ft)	Tension (lb)
1/0 ACSR	50	137
	75	204
	100	312
	125	387
	150	463
	175	537
	200	611
336 ACSR	50	198
	75	296
	100	456
	125	568
	150	680
	175	1506
	200	1708
653 ACSR	50	271
	75	406
	100	626
	125	782
	150	937
	175	1091
	200	1245

2.0 Ground Clearance

Per G.O. 95, use 130°F sags when calculating conductor-to-ground clearances.

Approved by:

ajf

Reduce Tension Span Sag Charts — Directions for Use

CO 168

Effective Date:
01-25-2019

What's Changed? Added new tension chart for guyed span tensions 35 kV 1/0 — 653 ACSR Covered Conductor in Light-Loading Areas.

Sheet 11 of 80

DOH

Scope CO 168.4 Sag Chart for New and Existing Reduced Tension Guyed Primary #6 — 4/0 Copper for Light-Loading Areas

Table CO 168–10: Sag Chart for New and Existing Reduced Tension Guyed Primary #6 — 4/0 Copper for Light-Loading Areas

Conductor Type	Span (ft)	Initial Sag	Final Sag
		50–110°F	130°F
#6 Copper	60	1'-6"	1'-8"
	80	2'-6"	2'-8"
	100	3'-6"	4'-0"
	120	5'-0"	6'-0"
	140	4'-0"	4'-2"
	160	5'-0"	5'-6"
	180	6'-0"	6'-10"
	200	7'-6"	8'-3"
#4 Copper	60	1'-6"	1'-6"
	80	2'-6"	2'-8"
	100	3'-6"	4'-0"
	120	5'-6"	5'-6"
	140	3'-6"	4'-0"
	160	4'-6"	4'-4"
	180	6'-0"	6'-6"
	200	7'-0"	7'-8"
#2 Copper	60	1'-6"	1'-7"
	80	2'-6"	2'-6"
	100	3'-6"	3'-7"
	120	4'-6"	5'-0"
	140	3'-6"	4'-0"
	160	4'-6"	5'-0"
	180	5'-6"	6'-0"
	200	6'-6"	7'-2"
2/0 Copper	60	1'-6"	1'-7"
	80	2'-0"	2'-1"
	100	3'-0"	3'-1"
	120	4'-6"	4'-7"
	140	3'-6"	3'-8"
	160	4'-0"	4'-6"
	180	5'-0"	5'-6"
	200	6'-0"	6'-6"
4/0 Copper	60	1'-6"	1'-6"
	80	2'-0"	2'-0"
	100	3'-0"	3'-1"
	120	4'-6"	4'-7"
	140	3'-6"	3'-8"
	160	4'-0"	4'-6"
	180	4'-6"	5'-6"
	200	6'-0"	6'-6"

Note(s):

1. Use on all 2.4 kV through 33 kV systems. 36-inch minimum mid span conductor spacing depending on deviation angle may require more than 36-inch pin spacing to achieve 36-inch conductor spacing.

CO 168

Reduce Tension Span Sag Charts — Directions for Use

Approved by:

ajf

Sheet 12 of 80

What's Changed?

Effective Date:

DOH

01-25-2019

3.0 Guyed Span Tensions

3.1 Conductor Tensions for Guying are 15 Percent of Full Tension for 60 to 120 Feet

- Conductor tension for guying #6 Copper is 45 lb
- Conductor tension for guying #4 Copper is 73 lb
- Conductor tension for guying #2 Copper is 115 lb
- Conductor tension for guying 2/0 Copper is 223 lb
- Conductor tension for guying 4/0 Copper is 345 lb

3.2 Conductor Tensions for Guying are 30 Percent of Full Tension for 121 to 200 Feet

- Conductor tension for guying #6 Copper is 90 lb
- Conductor tension for guying #4 Copper is 145 lb
- Conductor tension for guying #2 Copper is 228 lb
- Conductor tension for guying 2/0 Copper is 445 lb
- Conductor tension for guying 4/0 Copper is 685 lb

4.0 Ground Clearance

Per G.O. 95, use 130°F sags when calculating conductor-to-ground clearances.

Approved by: 	Reduce Tension Span Sag Charts — Directions for Use	C0 168
Effective Date: 01-25-2019	What's Changed?	Sheet 13 of 80 DOH

Scope CO 168.5 Sag Chart for New and Existing Reduced Tension Guyed Primary #2 — 4/0 Copper Covered Conductor for Light Loading Areas

Table CO 168–11: Sag Chart for New and Existing Reduced Tension Guyed Primary 17 kV #2 — 4/0 Copper Covered Conductor for Light-Loading Areas

Conductor Type	Span (ft)	Initial Sag	Final Sag
		50–110°F	130°F
#2 Copper	50	2'-0"	2'-2"
	75	3'-0"	3'-3"
	100	3'-6"	3'-10"
	125	4'-4"	4'-9"
	150	5'-2"	5'-9"
	175	6'-0"	6'-8"
	200	6'-11"	7'-8"
2/0 Copper	50	2'-0"	2'-2"
	75	3'-0"	3'-3"
	100	3'-6"	3'-10"
	125	4'-4"	4'-9"
	150	5'-3"	5'-9"
	175	6'-1"	6'-8"
	200	6'-11"	7'-8"
4/0 Copper	50	2'-0"	2'-2"
	75	3'-0"	3'-3"
	100	3'-6"	3'-10"
	125	4'-4"	4'-9"
	150	5'-3"	5'-9"
	175	6'-1"	6'-8"
	200	6'-11"	7'-8"

Note(s):

1. Use on all 2.4 kV through 17 kV systems. 36-inch minimum mid span conductor spacing depending on deviation angle may require more than 36-inch pin spacing to achieve 36-inch conductor spacing.

Table CO 168–12: Tension Table for New and Existing Reduced Tension Guyed Primary 17 kV #2 — 4/0 Copper Covered Conductor for Light-Loading Areas

Conductor Type	Span (ft)	Initial Tension (lb)	Final Tension (lb)
		50–110°F	130°F
#2 Copper	50	50	46
	75	75	70
	100	115	104
	125	144	130
	150	173	156
	175	202	182
	200	232	208
2/0 Copper	50	88	81
	75	132	122
	100	201	182
	125	251	228
	150	302	274
	175	352	319
	200	403	365
4/0 Copper	50	131	121
	75	196	182
	100	299	272
	125	374	340
	150	449	408
	175	524	476
	200	599	544

Approved by:

a/j

Reduce Tension Span Sag Charts — Directions for Use

CO 168

Effective Date:
01-25-2019

What's Changed? Updated tension chart for new and existing tension guyed primary 17 kV #2 — 4/0 Copper Covered Conductor in Light-Loading Areas.

Sheet 15 of 80

DOH

1.0 Guyed Span Tensions

Table CO 168–13: Guyed Span Tensions: 17 kV #2 — 4/0 Copper Covered Conductor for Light-Loading Areas

Conductor Type	Span (ft)	Tension (lb)
#2 Copper	50	87
	75	130
	100	198
	125	247
	150	295
	175	343
	200	391
2/0 Copper	50	123
	75	184
	100	283
	125	353
	150	423
	175	492
	200	562
4/0 Copper	50	165
	75	248
	100	381
	125	476
	150	570
	175	665
	200	759

2.0 Ground Clearance

Per G.O. 95, use 130°F sags when calculating conductor-to-ground clearances.

CO 168

Reduce Tension Span Sag Charts — Directions for Use

Approved by:



Sheet 16 of 80

What's Changed? Updated tension chart for guyed span tensions for 17 kV #2 — 4/0 Copper Covered Conductor in Light-Loading Areas.

Effective Date:

01-25-2019

DOH

Scope CO 168.6 Sag Chart for New and Existing Reduced Tension Guyed #6 — 1/0 Aluminum Duplex and Triplex for Light-Loading Areas

Table CO 168-14: Sag Chart for New and Existing Reduced Tension Guyed #6 — 1/0 Aluminum Duplex and Triplex for Light-Loading Areas

Conductor Type	Span (ft)	Initial Sag	Final Sag
		50–110°F	130°F
#6 Aluminum Duplex	60	8"	1'-0"
	80	1'-2"	1'-7"
	100	1'-10"	2'-4"
	120	2'-9"	3'-4"
	140	3'-9"	4'-4"
	160	5'-0"	5'-6"
#4 Aluminum Duplex	60	6"-0"	1'-0"
	80	1'-0"	1'-6"
	100	1'-6"	2'-2"
	120	2'-4"	2'-10"
	140	3'-2"	3'-10"
	160	4'-0"	4'-10"
#4 Aluminum Triplex	60	8"-0"	1'-1"
	80	1'-2"	1'-9"
	100	1'-10"	2'-6"
	120	2'-9"	3'-4"
	140	3'-9"	4'-4"
	160	4'-10"	5'-6"
#2 Aluminum Triplex	60	10"-0"	1'-1"
	80	1'-4"	1'-10"
	100	2'-0"	2'-6"
	120	2'-10"	3'-6"
	140	3'-10"	4'-6"
	160	5'-0"	5'-6"
1/0 Aluminum Triplex	60	7"-0"	1'-0"
	80	1'-0"	1'-6"
	100	1'-6"	2'-2"
	120	2'-0"	2'-10"
	140	2'-10"	3'-8"
	160	3'-6"	4'-7"

Approved by:



Reduce Tension Span Sag Charts — Directions for Use

CO 168

Sheet 17 of 80

Effective Date:
01-25-2019

What's Changed?

DOH

3.0 Guyed Span Tensions

3.1 Conductor Tensions for Guying are 50 Percent of Full Tension for 0 to 160 Feet

- Conductor tension for guying #6 Aluminum Duplex is 193 lb
- Conductor tension for guying #4 Aluminum Duplex is 302 lb
- Conductor tension for guying #4 Aluminum Triplex is 302 lb
- Conductor tension for guying #2 Aluminum Triplex is 380 lb
- Conductor tension for guying 1/0 Aluminum Triplex is 707 lb

4.0 Ground Clearance

Per G.O. 95, use 130°F sags when calculating conductor-to-ground clearances.

CO 168	Reduce Tension Span Sag Charts — Directions for Use	Approved by: <i>ajf</i>
Sheet 18 of 80	What's Changed?	Effective Date:
DOH		01-25-2019

Scope CO 168.7 Sag Chart for New and Existing Reduced Tension Guyed #4 — 4/0 Aluminum Quadruplex for Light-Loading Areas

Table CO 168–15: Sag Chart for New and Existing Reduced Tension Guyed #4 — 4/0 Aluminum Quadruplex for Light-Loading Areas

Conductor Type	Span (ft)	Initial Sag	Final Sag
		50–110°F	130°F
#4 Aluminum Quadruplex	60	10"-0"	1'-3"
	80	1'-6"	2'-0"
	100	2'-3"	2'-10"
	120	3'-3"	3'-10"
	140	4'-4"	5'-0"
	160	5'-9"	6'-4"
#1/0 Aluminum Quadruplex	60	8"-0"	1'-4"
	80	1'-2"	1'-9"
	100	1'-9"	2'-6"
	120	2'-6"	3'-10"
	140	3'-6"	4'-2"
	160	4'-6"	5'-2"
#4/0 Aluminum Quadruplex	60	7"-0"	1'-0"
	80	1'-0"	1'-7"
	100	1'-6"	2'-3"
	120	2'-2"	3'-0"
	140	2'-10"	3'-9"
	160	3'-8"	4'-7"

5.0 Guying Span Tensions

5.1 Conductor Tensions for Guying are 50 Percent of Full Tension for 0 to 160 Feet

- Conductor tension for guying #4 Aluminum Quadruplex is 302 lb
- Conductor tension for guying 1/0 Aluminum Quadruplex is 707 lb
- Conductor tension for guying 4/0 Aluminum Quadruplex is 1,390 lb

6.0 Ground Clearance

Per G.O. 95, use 130°F sags when calculating conductor-to-ground clearances.

Scope CO 168.8 Sag Chart for New Reduced Tension Unguyed #4 — 653 ACSR for Light-Loading Areas

Table CO 168–16: Sag Chart for New Reduced Tension Unguyed #4 — 653 ACSR for Light-Loading Areas

Conductor Type	Span (ft)	Initial Sag	Final Sag
		50–110°F	130°F
#4 ACSR ^{a/}	60	1'-6"	1'-8"
	80	2'-6"	2'-9"
	100	4'-0"	4'-1"
	120	5'-6"	5'-8"
1/0 ACSR	60	1'-6"	1'-7"
	80	2'-0"	2'-3"
	100	3'-0"	3'-3"
	120	4'-0"	4'-5"
336 ACSR	60	1'-6"	1'-7"
	80	2'-0"	2'-3"
	100	3'-0"	3'-3"
	120	4'-0"	4'-5"
653 ACSR	60	1'-6"	1'-9"
	80	2'-6"	2'-9"
	100	4'-0"	4'-1"
	120	5'-6"	5'-8"

^{a/} Not approved for new construction.

Note(s):

1. Use on all 2.4 kV through 33 kV systems. 36-inch minimum mid span conductor spacing depending on deviation angle may require more than 36-inch pin spacing to achieve 36-inch conductor spacing.

7.0 New Unguyed Span Tensions

7.1 Conductor Tensions are 10 Percent of Full Tension for 0 to 120 Feet

- Conductor tension for #4 ACSR is 60 lb
- Conductor tension for 1/0 ACSR is 142 lb
- Conductor tension for 336 ACSR is 285 lb
- Conductor tension for 653 ACSR is 327 lb

8.0 Ground Clearance

Per G.O. 95, use 130°F sags when calculating conductor-to-ground clearances.

Scope CO 168.9 Sag Chart for New Reduced Tension Unguyed 1/0 — 653 ACSR Covered Conductor for Light-Loading Areas

Table CO 168–17: Sag Chart for New Reduced Tension Unguyed 17 kV 1/0 — 653 ACSR Covered Conductor for Light-Loading Areas

Conductor Type	Span (ft)	Initial Sag	Final Sag
		50–110°F	130°F
1/0 ACSR	50	3'-9"	3'-10"
	75	5'-7"	5'-9"
	100	7'-6"	7'-7"
	125	9'-4"	9'-6"
336 ACSR	50	3'-9"	3'-10"
	75	5'-7"	5'-9"
	100	7'-6"	7'-8"
	125	9'-4"	9'-7"
653 ACSR	50	3'-9"	3'-10"
	75	5'-8"	5'-9"
	100	7'-6"	7'-8"
	125	9'-4"	9'-7"

Note(s):

1. Use on all 2.4 kV through 17 kV systems. 36-inch minimum mid span conductor spacing depending on deviation angle may require more than 36-inch pin spacing to achieve 36-inch conductor spacing.

Table CO 168–18: Tension Table for New Reduced Tension Unguyed 17 kV 1/0 — 653 ACSR Covered Conductor for Light-Loading Areas

Conductor Type	Span (ft)	Initial Tension	Final Tension
		50–110°F	130°F
1/0 ACSR	50	24	24
	75	36	36
	100	49	48
	125	61	60
336 ACSR	50	49	48
	75	74	72
	100	98	96
	125	123	120
653 ACSR	50	83	82
	75	125	123
	100	167	163
	125	208	204

Table CO 168–19: Sag Chart for New Reduced Tension Unguyed 35 kV 1/0 — 653 ACSR Covered Conductor for Light-Loading Areas

Conductor Type	Span (ft)	Initial Sag	Final Sag
		50–110°F	130°F
1/0 ACSR	50	3'-9"	3'-10"
	75	5'-7"	5'-9"
	100	7'-6"	7'-7"
	125	9'-4"	9'-6"
336 ACSR	50	3'-9"	3'-10"
	75	5'-7"	5'-9"
	100	7'-6"	7'-8"
	125	9'-4"	9'-7"
653 ACSR	50	3'-9"	3'-10"
	75	5'-8"	5'-9"
	100	7'-6"	7'-8"
	125	9'-4"	9'-7"

Table CO 168–20: Tension Table for New Reduced Tension Unguyed 35 kV 1/0 — 653 ACSR Covered Conductor for Light-Loading Areas

Conductor Type	Span (ft)	Initial Tension	Final Tension
		50–110°F	130°F
1/0 ACSR	50	39	39
	75	59	58
	100	79	77
	125	98	96
336 ACSR	50	69	68
	75	103	101
	100	137	135
	125	172	168
653 ACSR	50	106	104
	75	159	156
	100	212	207
	125	265	259

1.0 New Unguyed Span Tensions

Table CO 168–21: New Unguyed Span Tensions: 17 kV 1/0 — 653 ACSR Covered Conductor for Light-Loading Areas

Conductor Type	Span (ft)	Tension (lb)
1/0 ACSR	50	49
	75	74
	100	99
	125	124
336 ACSR	50	77
	75	116
	100	155
	125	194
653 ACSR	50	114
	75	171
	100	227
	125	284

Table CO 168–22: New Unguyed Span Tensions: 35 kV 1/0 — 653 ACSR Covered Conductor for Light-Loading Areas

Conductor Type	Span (ft)	Tension (lb)
1/0 ACSR	50	72
	75	108
	100	144
	125	180
336 ACSR	50	104
	75	155
	100	207
	125	259
653 ACSR	50	142
	75	212
	100	283
	125	354

2.0 Ground Clearance

Per G.O. 95, use 130°F sags when calculating conductor-to-ground clearances.

Approved by: <i>ajf</i>	Reduce Tension Span Sag Charts — Directions for Use	CO 168
Effective Date: 01-25-2019	What's Changed? Updated values for tension chart for new unguyed span tensions for 17 kV 1/0 — 653 ACSR CC. Added new table for 35 kV 1/0-653 ACSR CC.	Sheet 23 of 80
		DOH

Scope CO 168.10 Sag Chart for New Reduced Tension Unguyed #6 — 4/0 Copper for Light-Loading Areas

Table CO 168–23: Sag Chart for New Reduced Tension Unguyed #6 — 4/0 Copper for Light-Loading Areas

Conductor Type	Span (ft)	Initial Sag	Final Sag
		50–110°F	130°F
#6 Copper	60	1'-6"	1'-8"
	80	2'-6"	2'-8"
	100	3'-6"	4'-0"
	120	5'-0"	6'-0"
#4 Copper	60	1'-6"	1'-6"
	80	2'-6"	2'-8"
	100	3'-6"	4'-0"
	120	5'-6"	5'-6"
#2 Copper	60	1'-6"	1'-7"
	80	2'-6"	2'-6"
	100	3'-6"	3'-7"
	120	4'-6"	5'-0"
2/0 Copper	60	1'-6"	1'-7"
	80	2'-0"	2'-1"
	100	3'-0"	3'-1"
	120	4'-6"	4'-7"
4/0 Copper	60	1'-6"	1'-6"
	80	2'-0"	2'-0"
	100	3'-0"	3'-1"
	120	4'-6"	4'-7"

Note(s):

1. Use on all 2.4 kV through 33 kV systems. 36-inch minimum mid span conductor spacing depending on deviation angle may require more than 36-inch pin spacing to achieve 36-inch conductor spacing.

3.0 New Unguyed Span Tensions

3.1 Conductor Tensions are 15 Percent of Full Tension for 0 to 120 Feet

- Conductor tension for #6 Copper is 45 lb
- Conductor tension for #4 Copper is 73 lb
- Conductor tension for #2 Copper is 115 lb
- Conductor tension for 2/0 Copper is 223 lb
- Conductor tension for 4/0 Copper is 345 lb

4.0 Ground Clearance

Per G.O. 95, use 130°F sags when calculating conductor-to-ground clearances.

Scope CO 168.11 Sag Chart for New Reduced Tension Unguyed #2 — 4/0 Copper Covered Conductor for Light-Loading Areas

Table CO 168–24: Sag Chart for New Reduced Tension Unguyed 17 kV #2 — 4/0 Copper Covered Conductor for Light-Loading Areas

Conductor Type	Span (ft)	Initial Sag	Final Sag
		50–110°F	130°F
#2 Copper	50	3'-9"	3'-10"
	75	5'-7"	5'-9"
	100	7'-6"	7'-8"
	125	9'-4"	9'-7"
2/0 Copper	50	3'-9"	3'-10"
	75	5'-7"	5'-9"
	100	7'-6"	7'-8"
	125	9'-4"	9'-7"
2/0 Copper	50	3'-9"	3'-10"
	75	5'-7"	5'-9"
	100	7'-6"	7'-8"
	125	9'-4"	9'-7"

Note(s):

1. Use on all 2.4 kV through 17 kV systems. 36-inch minimum mid span conductor spacing depending on deviation angle may require more than 36-inch pin spacing to achieve 36-inch conductor spacing.

Table CO 168–25: Tension Table for New Reduced Tension Unguyed 17 kV #2 — 4/0 Copper Covered Conductor for Light-Loading Areas

Conductor Type	Span (ft)	Initial Tension	Final Tension
		50–110°F	130°F
#2 Copper	50	27	26
	75	41	40
	100	54	53
	125	68	66
2/0 Copper	50	47	46
	75	71	70
	100	95	93
	125	119	116
2/0 Copper	50	71	69
	75	106	104
	100	141	138
	125	177	173

1.0 New Unguyed Span Tensions

Table CO 168–26: New Unguyed Span Tensions: 17 kV #2 — 4/0 Copper Covered Conductor for Light-Loading Areas

Conductor Type	Span (ft)	Tension (lb)
#2 Copper	50	46
	75	69
	100	92
	125	114
2/0 Copper	50	65
	75	97
	100	130
	125	162
4/0 Copper	50	87
	75	131
	100	174
	125	218

2.0 Ground Clearance

Per G.O. 95, use 130°F sags when calculating conductor-to-ground clearances.

CO 168

Reduce Tension Span Sag Charts — Directions for Use

Approved by:

ajf

Sheet 26 of 80

What's Changed? Updated tension table for new unguyed spans 17 kV #2 — 4/0 Copper Covered Conductor for light-loading areas.

Effective Date:

01-25-2019

DOH

Scope CO 168.12 Sag Chart for New Reduced Tension Unguyed #6 — 1/0 Aluminum Duplex and Triplex for Light-Loading Areas

Table CO 168–27: Sag Chart for New Reduced Tension Unguyed #6 — 1/0 Aluminum Duplex and Triplex for Light- Loading Areas

Conductor Type	Span (ft)	Initial Sag	Final Sag
		50–110°F	130°F
#6 Aluminum Duplex	60	1'-6"	1'-8"
	80	2'-6"	2'-10"
	100	4'-0"	4'-6"
	120	5'-6"	6'-0"
#4 Aluminum Duplex	60	1'-6"	1'-7"
	80	2'-6"	2'-6"
	100	3'-6"	3'-7"
	120	4'-6"	5'-0"
#4 Aluminum Triplex	60	1'-6"	1'-8"
	80	2'-6"	2'-7"
	100	4'-0"	4'-2"
	120	5'-6"	6'-0"
#2 Aluminum Triplex	60	1'-6"	1'-8"
	80	2'-6"	4'-0"
	100	4'-0"	4'-2"
	120	5'-6"	6'-0"
1/0 Aluminum Triplex	60	1'-6"	1'-7"
	80	2'-0"	2'-2"
	100	3'-0"	3'-3"
	120	4'-0"	4'-6"

3.0 New Unguyed Span Tensions

3.1 Conductor Tensions are 25 Percent of Full Tension for 0 to 120 Feet

- Conductor tension for #6 Aluminum Duplex is 97 lb
- Conductor tension for #4 Aluminum Duplex is 150 lb
- Conductor tension for #4 Aluminum Triplex is 150 lb
- Conductor tension for #2 Aluminum Triplex is 355 lb
- Conductor tension for 1/0 Aluminum Triplex is 695 lb

4.0 Ground Clearance

Per G.O. 95, use 130°F sags when calculating conductor-to-ground clearances.

Approved by: <i>ajf</i>	Reduce Tension Span Sag Charts — Directions for Use	CO 168
Effective Date: 01-25-2019	What's Changed?	Sheet 27 of 80
		DOH

Scope CO 168.13 Sag Chart for New Reduced Tension Unguyed #4 — 4/0 Aluminum Quadruplex for Light-Loading Areas

Table CO 168–28: Sag Chart for New Reduced Tension Unguyed #4 — 4/0 Aluminum Quadruplex for Light-Loading Areas

Conductor Type	Span (ft)	Initial Sag	Final Sag
		50–110°F	130°F
#4 Aluminum Quadruplex	60	1'-6"	1'-10"
	80	3'-0"	3'-2"
	100	4'-6"	4'-8"
	120	6'-6"	6'-10"
#1/0 Aluminum Quadruplex	60	1'-0"	1'-7"
	80	2'-6"	2'-7"
	100	3'-5"	3'-9"
	120	5'-0"	5'-3"
#4/0 Aluminum Quadruplex	60	1'-6"	1'-7"
	80	2'-0"	2'-3"
	100	3'-0"	3'-3"
	120	4'-0"	4'-5"

5.0 New Unguyed Span Tensions

5.1 Conductor Tensions are 25 Percent of Full Tension for 0 to 120 Feet

- Conductor tension for #4 Aluminum Quadruplex is 150 lb
- Conductor tension for 1/0 Aluminum Quadruplex is 355 lb
- Conductor tension for 4/0 Aluminum Quadruplex is 695 lb

6.0 Ground Clearance

Per G.O. 95, use 130°F sags when calculating conductor-to-ground clearances.

Scope CO 168.14 Sag Chart for Existing and Rebuild Reduced Tension Unguyed #4 — 653 ACSR for Light-Loading Areas

Table CO 168–29: Sag Chart for Existing and Rebuild Reduced Tension Unguyed #4 — 653 ACSR for Light-Loading Areas

Conductor Type	Span (ft)	Initial Sag	Final Sag
		50–110°F	130°F
#4 ACSR ^{a/}	60	1'-6"	1'-8"
	80	2'-6"	2'-9"
	100	4'-0"	4'-1"
	120	5'-6"	5'-8"
	140	7'-6"	7'-7"
	160	9'-6"	9'-7"
1/0 ACSR	60	1'-6"	1'-7"
	80	2'-0"	2'-3"
	100	3'-0"	3'-3"
	120	4'-0"	4'-5"
	140	5'-6"	5'-8"
	160	7'-0"	7'-2"
336 ACSR	60	1'-6"	1'-7"
	80	2'-0"	2'-3"
	100	3'-0"	3'-3"
	120	4'-0"	4'-5"
	140	5'-6"	5'-7"
	160	7'-0"	7'-2"
653 ACSR	60	1'-6"	1'-9"
	80	2'-6"	2'-9"
	100	4'-0"	4'-1"
	120	5'-6"	5'-8"
	140	7'-0"	7'-2"
	160	9'-6"	9'-8"

^{a/} Not approved for new construction.

Note(s):

- Use on all 2.4 kV through 33 kV systems. 36-inch minimum mid span conductor spacing depending on deviation angle may require more than 36-inch pin spacing to achieve 36-inch conductor spacing.

7.0 Existing and Rebuild Unguyed Span Tensions

7.1 Conductor Tensions are 10 Percent of Full Tension for 0 to 160 Feet

- Conductor tension for #4 ACSR is 60 lb
- Conductor tension for 1/0 ACSR is 142 lb
- Conductor tension for 336 ACSR is 285 lb
- Conductor tension for 653 ACSR is 327 lb

8.0 Ground Clearance

Per G.O. 95, use 130°F sags when calculating conductor-to-ground clearances.

Approved by: <i>ajf</i>	Reduce Tension Span Sag Charts — Directions for Use	CO 168
Effective Date: 01-25-2019	What's Changed?	Sheet 29 of 80
		DOH

Scope CO 168.15 Sag Chart for Existing and Rebuild Reduced Tension Unguyed 1/0 — 653 ACSR Covered Conductor for Light-Loading Areas

Table CO 168–30: Sag Chart for Existing and Rebuild Reduced Tension Unguyed 17 kV 1/0 — 653 ACSR Covered Conductor for Light-Loading Areas

Conductor Type	Span (ft)	Initial Sag	Final Sag
		50–110°F	130°F
1/0 ACSR	50	3'-9"	3'-10"
	75	5'-7"	5'-9"
	100	7'-6"	7'-7"
	125	9'-4"	9'-6"
	150	10'-10"	11'-1"
	175	12'-2"	12'-6"
336 ACSR	50	3'-9"	3'-10"
	75	5'-7"	5'-9"
	100	7'-6"	7'-8"
	125	9'-4"	9'-7"
	150	10'-10"	11'-1"
	175	12'-3"	12'-7"
653 ACSR	50	3'-9"	3'-10"
	75	5'-8"	5'-9"
	100	7'-6"	7'-8"
	125	9'-4"	9'-7"
	150	10'-10"	11'-2"
	175	12'-3"	12'-7"

Note(s):

1. Use on all 2.4 kV through 17 kV systems. 36-inch minimum mid span conductor spacing depending on deviation angle may require more than 36-inch pin spacing to achieve 36-inch conductor spacing.

Table CO 168–31: Tension Table for Existing and Rebuild Reduced Tension Unguyed 17 kV 1/0 — 653 ACSR Covered Conductor for Light-Loading Areas

Conductor Type	Span (ft)	Initial Tension (lb)	Final Tension (lb)
		50–110°F	130°F
1/0 ACSR	50	24	24
	75	36	36
	100	49	48
	125	61	60
	150	75	74
	175	91	89
336 ACSR	50	49	48
	75	74	72
	100	98	96
	125	123	120
	150	152	149
	175	184	179
653 ACSR	50	83	82
	75	125	123
	100	167	163
	125	208	204
	150	258	252
	175	312	304

Table CO 168–32: Sag Chart for Existing and Rebuild Reduced Tension Unguyed 35 kV 1/0 — 653 ACSR Covered Conductor for Light-Loading Areas

Conductor Type	Span (ft)	Initial Sag	Final Sag
		50–110°F	130°F
1/0 ACSR	50	3'-9"	3'-10"
	75	5'-7"	5'-9"
	100	7'-6"	7'-7"
	125	9'-4"	9'-6"
	150	10'-10"	11'-1"
	175	12'-2"	12'-6"
336 ACSR	50	3'-9"	3'-10"
	75	5'-7"	5'-9"
	100	7'-6"	7'-8"
	125	9'-4"	9'-7"
	150	10'-10"	11'-2"
	175	12'-3"	12'-8"
653 ACSR	50	3'-9"	3'-10"
	75	5'-8"	5'-9"
	100	7'-6"	7'-8"
	125	9'-4"	9'-7"
	150	10'-10"	11'-2"
	175	12'-3"	12'-7"

Approved by:



Reduce Tension Span Sag Charts — Directions for Use

CO 168

Sheet 31 of 80

Effective Date:
01-25-2019

What's Changed? Added new tension values for unguyed existing and rebuild reduced tension for 17 kV 1/0 — 653 ACSR Covered Conductor. Added sag values for unguyed existing and rebuild reduced tension for 35 kV 1/0 — 653 ACSR Covered Conductor.

DOH

Table CO 168–33: Tension Table for Existing and Rebuild Reduced Tension Unguyed 35 kV 1/0 — 653 ACSR Covered Conductor for Light-Loading Areas

Conductor Type	Span (ft)	Initial Tension (lb)	Final Tension (lb)
		50–110°F	130°F
1/0 ACSR	50	39	39
	75	59	58
	100	79	77
	125	98	96
	150	122	119
	175	147	144
336 ACSR	50	103	101
	75	137	135
	100	172	168
	125	213	207
	150	257	249
	175	303	291
653 ACSR	50	106	104
	75	159	156
	100	212	207
	125	265	259
	150	328	320
	175	397	385

CO 168

Reduce Tension Span Sag Charts — Directions for Use

Approved by:



Sheet 32 of 80

What's Changed? Added new tension values for unguyed existing and rebuild reduced tension for 35 kV 1/0 — 653 ACSR Covered Conductor.

Effective Date:

01-25-2019

DOH

1.0 Existing and Rebuild Unguyed Span Tension

Table CO 168–34: Existing and Rebuild Unguyed Span Tensions: 17 kV 1/0 — 653 ACSR Covered Conductor for Light-Loading Areas

Conductor Type	Span (ft)	Tension (lb)
1/0 ACSR	50	49
	75	74
	100	99
	125	124
	150	153
	175	185
336 ACSR	50	77
	75	116
	100	155
	125	194
	150	240
	175	290
653 ACSR	50	114
	75	171
	100	227
	125	284
	150	353
	175	426

Approved by:

ajf

Reduce Tension Span Sag Charts — Directions for Use

CO 168

Effective Date:
01-25-2019

What's Changed? Updated tension values for unguyed existing and rebuild span tension for 17 kV 1/0 — 653 ACSR Covered Conductor.

Sheet 33 of 80

DOH

Table CO 168–35: Existing and Rebuild Unguyed Span Tensions: 35 kV 1/0 Covered Conductor for Light-Loading Areas

Conductor Type	Span (ft)	Tension (lb)
1/0 ACSR	50	72
	75	108
	100	144
	125	180
	150	223
	175	269
336 ACSR	50	104
	75	155
	100	207
	125	259
	150	321
	175	387
653 ACSR	50	142
	75	212
	100	283
	125	354
	150	439
	175	530

2.0 Ground Clearance

Per G.O. 95, use 130°F sags when calculating conductor-to-ground clearances.

CO 168

Reduce Tension Span Sag Charts — Directions for Use

Approved by:



Sheet 34 of 80

What's Changed? Added new tension values for unguyed existing and rebuild span tension for 35 kV 1/0 — 653 ACSR Covered Conductor.

Effective Date:

01-25-2019

DOH

Scope CO 168.16 Sag Chart for Existing and Rebuild Reduced Tension Unguyed #6 — 4/0 Copper for Light-Loading Areas

Table CO 168–36: Sag Chart for Existing and Rebuild Reduced Tension Unguyed #6 — 4/0 Copper for Light-Loading Areas

Conductor Type	Span (ft)	Initial Sag	Final Sag
		50–110°F	130°F
#6 Copper	60	1'-6"	1'-8"
	80	2'-6"	2'-8"
	100	3'-6"	4'-0"
	120	5'-0"	6'-0"
	140	4'-0"	4'-2"
	160	5'-0"	5'-6"
#4 Copper	60	1'-6"	1'-6"
	80	2'-6"	2'-8"
	100	3'-6"	4'-0"
	120	5'-6"	5'-6"
	140	3'-6"	4'-0"
	160	4'-6"	5'-4"
#2 Copper	60	1'-6"	1'-7"
	80	2'-6"	2'-6"
	100	3'-6"	3'-7"
	120	4'-6"	5'-0"
	140	3'-6"	4'-0"
	160	4'-6"	5'-0"
2/0 Copper	60	1'-6"	1'-7"
	80	2'-0"	2'-1"
	100	3'-0"	3'-1"
	120	4'-6"	4'-7"
	140	3'-6"	3'-8"
	160	4'-0"	4'-6"
4/0 Copper	60	1'-6"	1'-6"
	80	2'-0"	2'-0"
	100	3'-0"	3'-1"
	120	4'-6"	4'-7"
	140	3'-6"	3'-8"
	160	4'-0"	4'-6"

Note(s):

1. Use on all 2.4 kV through 33 kV systems. 36-inch minimum mid span conductor spacing depending on deviation angle may require more than 36-inch pin spacing to achieve 36-inch conductor spacing.

3.0 Existing and Rebuild Unguyed Span Tensions

3.1 Conductor Tensions are 15 Percent of Full Tension for 60 to 120 Feet

- Conductor tension for #6 Copper is 45 lb
- Conductor tension for #4 Copper is 73 lb
- Conductor tension for #2 Copper is 115 lb
- Conductor tension for 2/0 Copper is 223 lb
- Conductor tension for 4/0 Copper is 345 lb

3.2 Conductor Tensions are 30 Percent of Full Tension for 121 to 200 Feet

- Conductor tension for #6 Copper is 90 lb
- Conductor tension for #4 Copper is 145 lb
- Conductor tension for #2 Copper is 228 lb
- Conductor tension for 2/0 Copper is 445 lb
- Conductor tension for 4/0 Copper is 685 lb

4.0 Ground Clearance

Per G.O. 95, use 130°F sags when calculating conductor-to-ground clearances.

C0 168	Reduce Tension Span Sag Charts — Directions for Use	Approved by: <i>ajf</i>
Sheet 36 of 80	What's Changed?	Effective Date:
DOH		01-25-2019

Scope CO 168.17 Sag Chart for Existing and Rebuild Reduced Tension Unguyed #2 — 4/0 Copper Covered Conductor for Light-Loading Areas

Table CO 168–37: Sag Chart for Existing and Rebuild Reduced Tension Unguyed 17 kV #2 — 4/0 Copper Covered Conductor for Light-Loading Areas

Conductor Type	Span (ft)	Initial Sag	Final Sag
		50–110°F	130°F
#2 Copper	50	3'-9"	3'-10"
	75	5'-7"	5'-9"
	100	7'-6"	7'-8"
	125	9'-4"	9'-7"
	150	10'-10"	11'-2"
	175	12'-3"	12'-7"
2/0 Copper	50	3'-9"	3'-10"
	75	5'-7"	5'-9"
	100	7'-6"	7'-8"
	125	9'-4"	9'-7"
	150	10'-10"	11'-2"
	175	12'-3"	12'-7"
4/0 Copper	50	3'-9"	3'-10"
	75	5'-7"	5'-9"
	100	7'-6"	7'-8"
	125	9'-4"	9'-7"
	150	10'-10"	11'-2"
	175	12'-3"	12'-7"

Note(s):

1. Use on all 2.4 kV through 17 kV systems. 36-inch minimum mid span conductor spacing depending on deviation angle may require more than 36-inch pin spacing to achieve 36-inch conductor spacing.

Approved by: <i>ajf</i>	Reduce Tension Span Sag Charts — Directions for Use	CO 168
Effective Date: 01-25-2019	What's Changed? Updated sag values for existing and rebuild reduced tension unguyed for 17 kV #2 — 4/0 copper covered conductor.	Sheet 37 of 80
		DOH

Table CO 168–38: Tension Table for Existing and Rebuild Reduced Tension Unguyed 17 kV #2 — 4/0 Copper Covered Conductor for Light-Loading Areas

Conductor Type	Span (ft)	Initial Tension (lb)	Final Tension (lb)
		50–110°F	130°F
#2 Copper	50	27	26
	75	41	40
	100	54	53
	125	68	66
	150	84	82
	175	101	99
2/0 Copper	50	47	46
	75	71	70
	100	95	93
	125	119	116
	150	147	144
	175	177	173
4/0 Copper	50	71	69
	75	106	104
	100	141	138
	125	177	173
	150	219	214
	175	264	258

CO 168

Reduce Tension Span Sag Charts — Directions for Use

Approved by:



Sheet 38 of 80

What's Changed? Updated tension values for existing and rebuild reduced tension unguyed for 17 kV #2 — 4/0 copper covered conductor.

Effective Date:

01-25-2019

DOH

1.0 Existing and Rebuild Unguyed Span Tension

Table CO 168–39: Sag Chart for Existing and Rebuild Reduced Tension Unguyed 17 kV #2 — 4/0 Copper Covered Conductor for Light-Loading Areas

Conductor Type	Span (ft)	Tension (lb)
#2 Copper	50	46
	75	69
	100	92
	125	114
	150	142
	175	171
2/0 Copper	50	65
	75	97
	100	130
	125	162
	150	201
	175	243
4/0 Copper	50	87
	75	131
	100	174
	125	218
	150	270
	175	326

2.0 Ground Clearances

Per G.O. 95, use 130°F sags when calculating conductor-to-ground clearances.

**Scope CO 168.18 Sag Chart for Existing and Rebuild Reduced Tension Unguyed #6 —
4/0 Aluminum Duplex and Triplex for Light-Loading Areas**

**Table CO 168–40: Sag Chart for Existing and Rebuild Reduced Tension Unguyed #6 —
4/0 Aluminum Duplex and Triplex for Light-Loading Areas**

Conductor Type	Span (ft)	Initial Sag	Final Sag
		50–110°F	130°F
#6 Aluminum Duplex	60	1'-6"	1'-8"
	80	2'-6"	2'-10"
	100	4'-0"	4'-6"
	120	5'-6"	6'-0"
	140	3'-10"	4'-4"
	160	5'-0"	5'-7"
#4 Aluminum Duplex	60	1'-6"	1'-7"
	80	2'-6"	2'-6"
	100	3'-6"	3'-7"
	120	4'-6"	5'-0"
	140	3'-0"	3'-10"
	160	4'-0"	4'-10"
#4 Aluminum Triplex	60	1'-6"	1'-8"
	80	2'-6"	2'-7"
	100	4'-0"	4'-2"
	120	5'-6"	6'-0"
	140	3'-8"	4'-4"
	160	4'-10"	5'-6"
#2 Aluminum Triplex	60	1'-6"	1'-8"
	80	2'-6"	4'-0"
	100	4'-0"	4'-2"
	120	5'-6"	6'-0"
	140	3'-10"	4'-2"
	160	5'-0"	5'-7"
1/0 Aluminum Triplex	60	7"-0"	1'-0"
	80	1'-0"	1'-6"
	100	1'-6"	2'-2"
	120	2'-0"	2'-10"
	140	2'-10"	3'-8"
	160	3'-6"	4'-7"
1/0 Aluminum Duplex	60	1'-6"	1'-7"
	80	2'-0"	2'-2"
	100	3'-0"	3'-3"
	120	4'-0"	4'-6"
	140	2'-10"	3'-8"
	160	3'-7"	4'-7"
4/0 Aluminum Duplex	60	1'-0"	1'-3"
	80	1'-6"	2'-0"
	100	2'-6"	2'-9"
	120	3'-6"	3'-8"
	140	2'-3"	3'-4"
	160	3'-0"	4'-0"

CO 168

Reduce Tension Span Sag Charts — Directions for Use

Approved by:

ajf

Sheet 40 of 80

What's Changed?

Effective Date:

DOH

01-25-2019

3.0 Existing and Rebuild Unguyed Span Tensions

3.1 Conductor Tensions are 25 Percent of Full Tension for 0 to 120 Feet

- Conductor tension for #6 Aluminum Duplex is 97 lb
- Conductor tension for #4 Aluminum Duplex is 150 lb
- Conductor tension for #4 Aluminum Triplex is 150 lb
- Conductor tension for #2 Aluminum Triplex is 190 lb
- Conductor tension for 1/0 Aluminum Triplex is 355 lb
- Conductor tension for 4/0 Aluminum Triplex is 695 lb

3.2 Conductor Tensions are 50 Percent of Full Tension for 121 to 160 Feet

- Conductor tension for #6 Aluminum Duplex is 193 lb
- Conductor tension for #4 Aluminum Duplex is 302 lb
- Conductor tension for #4 Aluminum Triplex is 302 lb
- Conductor tension for #2 Aluminum Triplex is 380 lb
- Conductor tension for 1/0 Aluminum Triplex is 707 lb
- Conductor tension for 4/0 Aluminum Triplex is 1,390 lb

4.0 Ground Clearance

Per G.O. 95, use 130°F sags when calculating conductor-to-ground clearances.

Approved by: 	Reduce Tension Span Sag Charts — Directions for Use	C0 168
Effective Date: 01-25-2019	What's Changed?	Sheet 41 of 80 DOH

Scope CO 168.19 Sag Chart for New and Existing Reduced Tension Guyed #4 — 653 ACSR for Heavy-Loading Areas

Table CO 168-41: Sag Chart for New and Existing Reduced Tension Guyed #4 — 653 ACSR for Heavy-Loading Areas

Conductor Type	Span (ft)	Initial Sag	Final Sag
		50–110°F	130°F
#4 ACSR ^{a/}	60	1'-3"	1'-6"
	80	2'-2"	2'-6"
	100	3'-6"	3'-7"
	120	4'-10"	5'-2"
	140	6'-10"	7'-0"
	160	8'-9"	9'-0"
#2 ACSR ^{a/}	60	1'-3"	1'-6"
	80	2'-0"	2'-4"
	100	3'-0"	3'-4"
	120	4'-5"	4'-7"
	140	5'-10"	6'-2"
	160	7'-8"	8'-0"
1/0 ACSR	60	1'-0"	1'-1"
	80	1'-2"	1'-6"
	100	1'-10"	2'-4"
	120	2'-7"	3'-0"
	140	3'-6"	4'-0"
	160	4'-7"	5'-0"
336 ACSR	60	1'-3"	1'-6"
	80	2'-0"	2'-4"
	100	2'-10"	3'-3"
	120	4'-0"	4'-5"
	140	5'-4"	5'-8"
	160	6'-8"	7'-2"
653 ACSR	60	1'-6"	1'-9"
	80	2'-3"	2'-6"
	100	3'-4"	3'-7"
	120	5'-6"	5'-8"
	140	6'-0"	6'-5"
	160	7'-0"	8'-2"

^{a/} Not approved for new construction.

Note(s):

1. ^{a/}Use on all 2.4 kV through 33 kV systems. 36-inch minimum mid span conductor spacing depending on deviation angle may require more than 36-inch pin spacing to achieve 36-inch conductor spacing.

CO 168

Reduce Tension Span Sag Charts — Directions for Use

Approved by:



Sheet 42 of 80

What's Changed?

Effective Date:

DOH

01-25-2019

5.0 Guyed Span Tensions

5.1 Conductor Tensions for Guying are 50 Percent of Full Tension for 0 to 160 Feet

- Conductor tension for guying #4 ACSR is 302 lb
- Conductor tension for guying #2 ACSR is 380 lb
- Conductor tension for guying 1/0 ACSR is 707 lb

5.2 Conductor Tensions for Guying are 25 Percent of Full Tension for 0 to 160 Feet

- Conductor tension for guying 336 ACSR is 710 lb
- Conductor tension for guying 653 ACSR is 815 lb

6.0 Ground Clearance

Per G.O. 95, use 130°F sags when calculating conductor-to-ground clearances.

Approved by: 	Reduce Tension Span Sag Charts — Directions for Use	CO 168
Effective Date: 01-25-2019	What's Changed?	Sheet 43 of 80 DOH

Scope CO 168.20 Sag Chart for New and Existing Reduced Tension Guyed 1/0— 653 ACSR Covered Conductor for Heavy-Loading Areas

Table CO 168–42: Sag Chart for New and Existing Reduced Tension Guyed 17 kV 1/0 — 653 ACSR Covered Conductor for Heavy-Loading Areas

Conductor Type	Span (ft)	Initial Sag	Final Sag
		50–110°F	130°F
1/0 ACSR	50	2'-0"	2'-1"
	75	3'-0"	3'-2"
	100	3'-5"	3'-9"
	125	4'-4"	4'-9"
	150	5'-2"	5'-8"
	175	6'-0"	6'-7"
336 ACSR	50	2'-0"	2'-1"
	75	3'-0"	3'-2"
	100	3'-6"	3'-10"
	125	4'-4"	4'-10"
	150	5'-2"	5'-10"
	175	6'-0"	6'-10"
653 ACSR	50	2'-0"	2'-2"
	75	3'-0"	3'-3"
	100	3'-6"	3'-10"
	125	4'-4"	4'-10"
	150	5'-2"	5'-10"
	175	6'-0"	6'-10"

Note(s):

- Use on all 2.4 kV through 17 kV systems. 36-inch minimum mid span conductor spacing depending on deviation angle may require more than 36-inch pin spacing to achieve 36-inch conductor spacing.

Table CO 168–43: Tension Table for New and Existing Reduced Tension Guyed 17 kV 1/0 — 653 ACSR Covered Conductor for Heavy-Loading Areas

Conductor Type	Span (ft)	Initial Tension (lb)	Final Tension (lb)
		50–110°F	130°F
1/0 ACSR	50	45	43
	75	68	64
	100	104	95
	125	130	118
	150	156	142
	175	183	165
336 ACSR	50	91	86
	75	136	127
	100	208	188
	125	261	232
	150	314	277
	175	367	323
653 ACSR	50	154	144
	75	231	215
	100	353	320
	125	443	397
	150	533	474
	175	624	549

Table CO 168–44: Sag Chart for New and Existing Reduced Tension Guyed 35 kV 1/0 — 653 ACSR Covered Conductor for Heavy-Loading Areas

Conductor Type	Span (ft)	Initial Sag	Final Sag
		50–110°F	130°F
1/0 ACSR	50	2'-0"	2'-1"
	75	3'-0"	3'-2"
	100	3'-5"	3'-10"
	125	4'-3"	4'-9"
	150	5'-1"	5'-9"
	175	5'-11"	6'-8"
336 ACSR	50	2'-0"	2'-2"
	75	3'-0"	3'-3"
	100	3'-6"	3'-11"
	125	4'-4"	4'-11"
	150	5'-2"	5'-10"
	175	5'-10"	6'-8"
653 ACSR	50	2'-0"	2'-2"
	75	3'-0"	3'-3"
	100	3'-6"	3'-10"
	125	4'-4"	4'-10"
	150	5'-2"	5'-11"
	175	6'-0"	6'-10"

Approved by:



Reduce Tension Span Sag Charts — Directions for Use

CO 168

Sheet 45 of 80

Effective Date:
01-25-2019

What's Changed? Added new tension values for new and existing reduced tension guyed for 17 kV 1/0 — 653 ACSR CC for heavy-loading areas. Added new sag values for new and existing reduced tension guyed for 35 kV 1/0 — 653 ACSR CC for heavy-loading areas.

DOH

Table CO 168–45: Tension Table for New and Existing Reduced Tension Guyed 35 kV 1/0 — 653 ACSR Covered Conductor for Heavy-Loading Areas

Conductor Type	Span (ft)	Initial Tension (lb)	Final Tension (lb)
		50–110°F	130°F
1/0 ACSR	50	73	69
	75	110	102
	100	168	152
	125	211	190
	150	255	227
	175	299	265
336 ACSR	50	127	119
	75	191	177
	100	292	259
	125	367	323
	150	442	388
	175	527	466
653 ACSR	50	195	183
	75	294	273
	100	450	404
	125	565	501
	150	681	597
	175	798	697

CO 168

Reduce Tension Span Sag Charts — Directions for Use

Approved by:



Sheet 46 of 80

What's Changed? Added new tension values for new and existing reduced tension guyed for 35 kV 1/0 — 653 ACSR CC for heavy-loading areas.

Effective Date:

01-25-2019

DOH

1.0 Guyed Span Tensions

Table CO 168–46: Guyed Span Tensions: 17 kV 1/0 — 653 ACSR Covered Conductor for Heavy-Loading Areas

Conductor Type	Span (ft)	Tension (lb)
1/0 ACSR	50	229
	75	340
	100	514
	125	633
	150	750
	175	864
336 ACSR	50	313
	75	467
	100	719
	125	892
	150	1062
	175	1230
653 ACSR	50	414
	75	617
	100	958
	125	1191
	150	1422
	175	1651

Approved by:

ajf

Reduce Tension Span Sag Charts — Directions for Use

CO 168

Effective Date:
01-25-2019

What's Changed? Updated tension values for new and existing reduced tension guyed for 17 kV 1/0 — 653 ACSR CC for heavy-loading areas.

Sheet 47 of 80

DOH

Table CO 168–47: Guyed Span Tensions: 35 kV 1/0 — 653 ACSR Covered Conductor for Heavy-Loading Areas

Conductor Type	Span (ft)	Tension (lb)
1/0 ACSR	50	291
	75	431
	100	648
	125	798
	150	943
	175	1086
336 ACSR	50	386
	75	575
	100	883
	125	1094
	150	1302
	175	1506
653 ACSR	50	491
	75	732
	100	1135
	125	1410
	150	1683
	175	1952

2.0 Ground Clearance

Per G.O. 95, use 130°F sags when calculating conductor-to-ground clearances.

Scope CO 168.21 Sag Chart for New and Existing Reduced Tension Guyed #6 — 4/0 Copper for Heavy-Loading Areas

Table CO 168–48: Sag Chart for New and Existing Reduced Tension Guyed #6 — 4/0 Copper for Heavy-Loading Areas

Conductor Type	Span (ft)	Initial Sag	Final Sag
		50–110°F	130°F
#6 Copper ^{a/}	60	1'-6"	1'-10"
	80	2'-10"	3'-0"
	100	4'-4"	4'-6"
	120	6'-0"	6'-6"
	140	N/A ^{b/}	N/A ^{b/}
	160	N/A ^{b/}	N/A ^{b/}
#4 Copper ^{a/}	60	1'-3"	1'-6"
	80	2'-0"	2'-5"
	100	3'-2"	3'-6"
	120	4'-6"	5'-0"
	140	6'-3"	6'-7"
	160	N/A	N/A ^{b/}
#2 Copper ^{a/}	60	1'-0"	1'-7"
	80	1'-6"	2'-0"
	100	2'-4"	2'-9"
	120	3'-4"	3'-9"
	140	4'-6"	5'-0"
	160	5'-10"	6'-4"
2/0 Copper	60	1'-2"	1'-6"
	80	2'-0"	2'-3"
	100	2'-10"	3'-3"
	120	4'-0"	4'-6"
	140	5'-4"	5'-9"
	160	6'-10"	7'-4"
4/0 Copper	60	1'-2"	1'-6"
	80	1'-8"	2'-0"
	100	2'-5"	2'-10"
	120	3'-4"	3'-10"
	140	4'-6"	4'-10"
	160	5'-8"	6'-3"

^{a/} Not approved for new construction.

^{b/} Excessive sagging, use full tension.

Note(s):

1. Use on all 2.4 kV through 33 kV systems. 36-inch minimum mid span conductor spacing depending on deviation angle may require more than 36-inch pin spacing to achieve 36-inch conductor spacing.

3.0 Guyed Span Tensions

3.1 Conductor Tensions for Guying are 70 Percent of Full Tension for 60 to 160 Feet

- Conductor tension for guying #6 Copper is 225 lb
- Conductor tension for guying #4 Copper is 340 lb
- Conductor tension for guying #2 Copper is 533 lb

3.2 Conductor Tensions for Guying are 40 Percent of Full Tension for 60 to 160 Feet

- Conductor tension for guying 2/0 Copper is 593 lb

3.3 Conductor Tensions for Guying are 30 Percent of Full Tension for 60 to 160 Feet

- Conductor tension for guying 4/0 Copper is 915 lb

4.0 Ground Clearance

Per G.O. 95, use 130°F sags when calculating conductor-to-ground clearances.

C0 168	Reduce Tension Span Sag Charts — Directions for Use	Approved by: <i>ajf</i>
Sheet 50 of 80	What's Changed?	Effective Date:
DOH		01-25-2019

Scope CO 168.22 Sag Chart for New and Existing Reduced Tension Guyed #2 — 4/0 Copper Covered Conductor for Heavy-Loading Areas

Table CO 168-49: Sag Chart for New and Existing Reduced Tension Guyed 17 kV #2 — 4/0 Copper Covered Conductor for Heavy-Loading Areas

Conductor Type	Span (ft)	Initial Sag	Final Sag
		50–110°F	130°F
#2 Copper	50	2'-0"	2'-2"
	75	3'-0"	3'-3"
	100	3'-6"	3'-10"
	125	4'-4"	4'-9"
	150	5'-2"	5'-9"
	175	6'-0"	6'-8"
2/0 Copper	50	2'-0"	2'-2"
	75	3'-0"	3'-3"
	100	3'-6"	3'-10"
	125	4'-4"	4'-9"
	150	5'-3"	5'-9"
	175	6'-1"	6'-8"
4/0 Copper	50	2'-0"	2'-2"
	75	3'-0"	3'-3"
	100	3'-6"	3'-10"
	125	4'-4"	4'-9"
	150	5'-3"	5'-9"
	175	6'-1"	6'-8"

Note(s):

1. Use on all 2.4 kV through 17 kV systems. 36-inch minimum mid span conductor spacing depending on deviation angle may require more than 36-inch pin spacing to achieve 36-inch conductor spacing.

Approved by:

ajf

Reduce Tension Span Sag Charts — Directions for Use

CO 168

Effective Date:
01-25-2019

What's Changed? Updated sag values for new and existing reduced tension guyed for 17 kV #2 — 4/0 Copper CC for heavy-loading areas.

Sheet 51 of 80

DOH

Table CO 168–50: Tension Table for New and Existing Reduced Tension Guyed 17 kV #2 — 4/0 Copper Covered Conductor for Heavy-Loading Areas

Conductor Type	Span (ft)	Initial Tension (lb)	
		50–110°F	130°F
#2 Copper	50	50	46
	75	75	70
	100	115	104
	125	144	130
	150	173	156
	175	202	182
2/0 Copper	50	88	81
	75	132	122
	100	201	182
	125	251	228
	150	302	274
	175	352	319
4/0 Copper	50	131	121
	75	196	182
	100	299	272
	125	374	340
	150	449	408
	175	524	476

CO 168

Reduce Tension Span Sag Charts — Directions for Use

Approved by:



Sheet 52 of 80

What's Changed? Added new tension values for new and existing reduced tension guyed for 17 kV #2 — 4/0 Copper CC for heavy-loading areas.

Effective Date:

01-25-2019

DOH

1.0 Guyed Span Tensions

Table CO 168–51: Guyed Span Tensions: 17 kV #2 — 4/0 Copper Covered Conductor for Heavy-Loading Areas

Conductor Type	Span (ft)	Tension (lb)
#2 Copper	50	216
	75	321
	100	483
	125	594
	150	703
	175	810
2/0 Copper	50	267
	75	398
	100	608
	125	753
	150	896
	175	1036
4/0 Copper	50	322
	75	481
	100	738
	125	917
	150	1093
	175	1268

2.0 Ground Clearance

Per G.O. 95, use 130°F sags when calculating conductor-to-ground clearances.

Scope CO 168.23 Sag Chart for New and Existing Reduced Tension Guyed #6 — 1/0 Aluminum Duplex and Triplex for Heavy-Loading Areas

Table CO 168–52: Sag Chart for New and Existing Reduced Tension Guyed #6 — 1/0 Aluminum Duplex and Triplex for Heavy-Loading Areas

Conductor Type	Span (ft)	Initial Sag	Final Sag
		50–110°F	130°F
#6 Aluminum Duplex	60	1'-6"	1'-8"
	80	2'-6"	2'-10"
	100	4'-0"	4'-6"
	120	6'-0"	6'-3"
	140	8'-3"	8'-6"
	160	11'-0"	11'-1"
#4 Aluminum Duplex	60	1'-0"	1'-3"
	80	1'-8"	2'-2"
	100	2'-9"	3'-3"
	120	4'-4"	4'-6"
	140	5'-10"	6'-3"
	160	7'-6"	8'-0"
#4 Aluminum Triplex	60	1'-0"	1'-3"
	80	2'-0"	2'-4"
	100	3'-0"	3'-6"
	120	4'-6"	4'-7"
	140	6'-5"	6'-8"
	160	8'-6"	8'-9"
#2 Aluminum Triplex	60	1'-0"	1'-5"
	80	2'-0"	2'-3"
	100	3'-0"	3'-6"
	120	4'-5"	4'-9"
	140	6'-0"	6'-4"
	160	7'-10"	8'-3"
1/0 Aluminum Triplex	60	1'-3"	1'-5"
	80	2'-0"	2'-4"
	100	3'-0"	3'-6"
	120	4'-6"	4'-8"
	140	6'-10"	6'-4"
	160	7'-9"	8'-3"
4/0 Aluminum Triplex	60	1'-6"	1'-8"
	80	2'-5"	2'-8"
	100	3'-8"	3'-10"
	120	5'-3"	5'-6"
	140	7'-0"	7'-4"
	160	9'-0"	9'-6"

3.0 Guyed Span Tensions

- 3.1 Conductor Tensions for Guying are 75 Percent of Full Tension for 0 to 160 Feet
- Conductor tension for guying #6 Aluminum Duplex is 290 lb
 - Conductor tension for guying #4 Aluminum Duplex is 453 lb
 - Conductor tension for guying #4 Aluminum Triplex is 453 lb
 - Conductor tension for guying #2 Aluminum Triplex is 570 lb
- 3.2 Conductor Tensions for Guying are 50 Percent of Full Tension for 0 to 160 Feet
- Conductor tension for guying 1/0 Aluminum Triplex is 707 lb
- 3.3 Conductor Tensions for Guying are 30 Percent of Full Tension for 0 to 160 Feet
- Conductor tension for guying 4/0 Aluminum Triplex is 835 lb

4.0 Ground Clearance

Per G.O. 95, use 130°F sags when calculating conductor-to-ground clearances.

Approved by: 	Reduce Tension Span Sag Charts — Directions for Use	C0 168
Effective Date: 01-25-2019	What's Changed?	Sheet 55 of 80 DOH

Scope CO 168.24 Sag Chart for New and Existing Reduced Tension Guyed #4 — 4/0 Aluminum Quadruplex for Heavy-Loading Area

Table CO 168–53: Sag Chart for New and Existing Reduced Tension Guyed #4 — 4/0 Aluminum Quadruplex for Heavy-Loading Areas

Conductor Type	Span (ft)	Initial Sag	Final Sag
		50–110°F	130°F
#4 Aluminum Quadruplex	60	1'-2"	1'-6"
	80	2'-3"	2'-6"
	100	3'-6"	3'-10"
	120	5'-3"	5'-6"
	140	7'-0"	7'-5"
	160	9'-4"	9'-8"
#1/0 Aluminum Quadruplex	60	1'-4"	1'-7"
	80	2'-2"	2'-7"
	100	3'-5"	3'-10"
	120	5'-0"	5'-5"
	140	6'-9"	7'-0"
	160	8'-9"	9'-2"
#4/0 Aluminum Quadruplex	60	1'-7"	1'-10"
	80	2'-0"	3'-0"
	100	4'-3"	4'-6"
	120	6'-0"	6'-3"
	140	8'-0"	8'-4"
	160	10'-5"	10'-9"

5.0 Guyed Span Tensions

- 5.1 Conductor Tensions for Guying are 75 Percent of Full Tension for 0 to 160 Feet
 - Conductor tension for guying #4 Aluminum Quadruplex is 453 lb
- 5.2 Conductor Tensions for Guying are 50 Percent of Full Tension for 0 to 160 Feet
 - Conductor tension for guying 1/0 Aluminum Quadruplex is 707 lb
- 5.3 Conductor Tensions for Guying are 39 Percent of Full Tension for 0 to 160 Feet
 - Conductor tension for guying 4/0 Aluminum Quadruplex is 835 lb

6.0 Ground Clearance

Per G.O. 95, use 130°F sags when calculating conductor-to-ground clearances.

Scope CO 168.25 Sag Chart for New Reduced Tension Unguyed #4 — 653 ACSR for Heavy-Loading Areas

Table CO 168–54: Sag Chart for New Reduced Tension Unguyed #4 — 653 ACSR for Heavy-Loading Areas

Conductor Type	Span (ft)	Initial Sag	Final Sag
		50–110°F	130°F
#4 ACSR ^{a/}	60	1'-3"	1'-6"
	80	2'-2"	2'-6"
	100	3'-6"	3'-7"
	120	4'-10"	5'-2"
#2 ACSR ^{a/}	60	1'-3"	1'-6"
	80	2'-0"	2'-4"
	100	3'-0"	3'-4"
	120	4'-5"	4'-7"
1/0 ACSR	60	1'-0"	1'-1"
	80	1'-2"	1'-6"
	100	1'-10"	2'-4"
	120	2'-7"	3'-0"
336 ACSR	60	1'-3"	1'-6"
	80	2'-0"	2'-4"
	100	2'-10"	3'-3"
	120	4'-0"	4'-5"
653 ACSR	60	1'-6"	1'-9"
	80	2'-3"	2'-6"
	100	3'-4"	3'-7"
	120	5'-6"	5'-8"

^{a/} Not approved for new construction.

Note(s):

- Use on all 2.4 kV through 33 kV systems. 36-inch minimum mid span conductor spacing depending on deviation angle may require more than 36-inch pin spacing to achieve 36-inch conductor spacing.

7.0 New Unguyed Span Tensions

7.1 Conductor Tensions are 50 Percent of Full Tension for 0 to 120 Feet

- Conductor tension for #4 ACSR is 302 lb
- Conductor tension for #2 ACSR is 380 lb
- Conductor tension for 1/0 ACSR is 707 lb

7.2 Conductor Tensions are 25 Percent of Full Tension for 0 to 120 Feet

- Conductor tension for 336 ACSR is 710 lb
- Conductor tension for 653 ACSR is 815 lb

8.0 Ground Clearance

Per G.O. 95, use 130°F sags when calculating conductor-to-ground clearances.

Approved by: 	Reduce Tension Span Sag Charts — Directions for Use	CO 168
Effective Date: 01-25-2019	What's Changed?	Sheet 57 of 80
		DOH

Scope CO 168.26 Sag Chart for New Reduced Tension Unguyed 1/0 — 653 ACSR Covered Conductor for Heavy-Loading Areas

Table CO 168–55: Sag Chart for New Reduced Tension Unguyed 17 kV 1/0 — 653 ACSR Covered Conductor for Heavy-Loading Areas

Conductor Type	Span (ft)	Initial Sag	Final Sag
		50–110°F	130°F
1/0 ACSR	50	3'-9"	3'-10"
	75	5'-7"	5'-9"
	100	7'-6"	7'-7"
	125	9'-4"	9'-6"
336 ACSR	50	3'-9"	3'-10"
	75	5'-7"	5'-9"
	100	7'-6"	7'-7"
	125	9'-4"	9'-7"
653 ACSR	50	3'-9"	3'-10"
	75	5'-8"	5'-9"
	100	7'-6"	7'-8"
	125	9'-4"	9'-7"

Note(s):

1. Use on all 2.4 kV through 17 kV systems. 36-inch minimum mid span conductor spacing depending on deviation angle may require more than 36-inch pin spacing to achieve 36-inch conductor spacing.

Table CO 168–56: Tension Table for New Reduced Tension Unguyed 17 kV 1/0 — 653 ACSR Covered Conductor for Heavy-Loading Areas

Conductor Type	Span (ft)	Initial Tension	Final Tension
		50–110°F	130°F
1/0 ACSR	50	24	24
	75	36	36
	100	49	48
	125	61	60
336 ACSR	50	49	48
	75	74	72
	100	98	96
	125	123	120
653 ACSR	50	83	82
	75	125	123
	100	167	163
	125	208	204

Table CO 168–57: Sag Chart for New Reduced Tension Unguyed 35 kV 1/0 — 653 ACSR Covered Conductor for Heavy-Loading Areas

Conductor Type	Span (ft)	Initial Sag	Final Sag
		50–110°F	130°F
1/0 ACSR	50	3'-9"	3'-10"
	75	5'-7"	5'-9"
	100	7'-6"	7'-7"
	125	9'-4"	9'-6"
336 ACSR	50	3'-9"	3'-10"
	75	5'-7"	5'-9"
	100	7'-6"	7'-8"
	125	9'-4"	9'-7"
653 ACSR	50	3'-9"	3'-10"
	75	5'-8"	5'-9"
	100	7'-6"	7'-8"
	125	9'-4"	9'-7"

Table CO 168–58: Tension Table for New Reduced Tension Unguyed 35 kV 1/0 — 653 ACSR Covered Conductor for Heavy-Loading Areas

Conductor Type	Span (ft)	Initial Tension	Final Tension
		50–110°F	130°F
1/0 ACSR	50	39	39
	75	59	58
	100	79	77
	125	98	96
336 ACSR	50	69	68
	75	103	101
	100	137	135
	125	172	168
653 ACSR	50	106	104
	75	159	156
	100	212	207
	125	265	259

Approved by:

ajf

Reduce Tension Span Sag Charts — Directions for Use

CO 168

Effective Date:
01-25-2019

What's Changed? Added new sag and tension values for new reduced unguyed tension spans for 35 kV 1/0 — 653 ACSR CC for heavy-loading areas.

Sheet 59 of 80

DOH

1.0 New Unguyed Span Tensions

Table CO 168–59: New Unguyed Span Tensions: 17 kV 1/0 — 653 ACSR Covered Conductor for Heavy-Loading Areas

Conductor Type	Span (ft)	Tension (lb)
1/0 ACSR	50	119
	75	179
	100	238
	125	297
336 ACSR	50	160
	75	240
	100	320
	125	399
653 ACSR	50	210
	75	315
	100	420
	125	525

Table CO 168–60: New Unguyed Span Tensions: 35 kV 1/0 — 653 ACSR Covered Conductor for Heavy-Loading Areas

Conductor Type	Span (ft)	Tension (lb)
1/0 ACSR	50	152
	75	228
	100	303
	125	378
336 ACSR	50	198
	75	296
	100	395
	125	493
653 ACSR	50	250
	75	375
	100	499
	125	623

2.0 Ground Clearance

Per G.O. 95, use 130°F sags when calculating conductor-to-ground clearances.

CO 168

Reduce Tension Span Sag Charts — Directions for Use

Approved by:

ajf

Sheet 60 of 80

What's Changed? Updated tension values for new unguyed tension spans for 17 kV 1/0 — 653 ACSR CC for heavy-loading areas. Added new tension values for new unguyed tension spans for 35 kV 1/0 — 653 ACSR CC for heavy-loading areas.

Effective Date:

01-25-2019

DOH

Scope CO 168.27 Sag Chart for New Reduced Tension Unguyed #6 — 4/0 Copper for Heavy-Loading Areas

Table CO 168–61: Sag Chart for New Reduced Tension Unguyed #6 — 4/0 Copper for Heavy-Loading Areas

Conductor Type	Span (ft)	Initial Sag	Final Sag
		50–110°F	130°F
#6 Copper ^{a/}	60	1'-6"	1'-10"
	80	2'-10"	3'-0"
	100	4'-4"	4'-6"
	120	6'-0"	6'-6"
#4 Copper ^{a/}	60	1'-3"	1'-6"
	80	2'-0"	2'-5"
	100	3'-2"	3'-6"
	120	4'-6"	5'-0"
#2 Copper ^{a/}	60	1'-0"	1'-7"
	80	1'-6"	2'-0"
	100	2'-4"	2'-9"
	120	3'-4"	3'-9"
2/0 Copper	60	1'-2"	1'-6"
	80	2'-0"	2'-3"
	100	2'-10"	3'-3"
	120	4'-0"	4'-6"
4/0 Copper	60	1'-2"	1'-6"
	80	1'-8"	2'-0"
	100	2'-5"	2'-10"
	120	3'-4"	3'-10"

^{a/} Not approved for new construction.

Note(s):

1. Use on all 2.4 kV through 33 kV systems. 36-inch minimum mid span conductor spacing depending on deviation angle may require more than 36-inch pin spacing to achieve 36-inch conductor spacing.

3.0 New Unguyed Span Tensions

3.1 Conductor Tensions are 70 Percent of Full Tension for 60 to 120 Feet

- Conductor tension for #6 Copper is 225 lb
- Conductor tension for #4 Copper is 340 lb
- Conductor tension for #2 Copper is 533 lb

3.2 Conductor Tensions are 40 Percent of Full Tension for 60 to 120 Feet

- Conductor tension for 2/0 Copper is 593 lb

3.3 Conductor Tensions are 30 Percent of Full Tension for 60 to 120 Feet

- Conductor tension for 4/0 Copper is 915 lb

4.0 Ground Clearance

Per G.O. 95, use 130°F sags when calculating conductor-to-ground clearances.

Approved by: <i>ajf</i>	Reduce Tension Span Sag Charts — Directions for Use	CO 168
Effective Date: 01-25-2019	What's Changed?	Sheet 61 of 80
		DOH

Scope CO 168.28 Sag Chart for New Reduced Tension Unguyed #2 — 4/0 Copper Covered Conductor for Heavy-Loading Areas

Table CO 168–62: Sag Chart for New Reduced Tension Unguyed 17 kV #2 — 4/0 Copper Covered Conductor for Heavy-Loading Areas

Conductor Type	Span (ft)	Initial Sag	Final Sag
		50–110°F	130°F
#2 Copper	50	3'-9"	3'-10"
	75	5'-7"	5'-9"
	100	7'-6"	7'-8"
	125	9'-4"	9'-7"
2/0 Copper	50	3'-9"	3'-10"
	75	5'-7"	5'-9"
	100	7'-6"	7'-8"
	125	9'-4"	9'-7"
2/0 Copper	50	3'-9"	3'-10"
	75	5'-7"	5'-9"
	100	7'-6"	7'-8"
	125	9'-4"	9'-7"

Note(s):

1. Use on all 2.4 kV through 17 kV systems. 36-inch minimum mid span conductor spacing depending on deviation angle may require more than 36-inch pin spacing to achieve 36-inch conductor spacing.

Table CO 168–63: Tension Table for New Reduced Tension Unguyed 17 kV #2 — 4/0 Copper Covered Conductor for Heavy-Loading Areas

Conductor Type	Span (ft)	Initial Tension	Final Tension
		50–110°F	130°F
#2 Copper	50	27	26
	75	41	40
	100	54	53
	125	68	66
2/0 Copper	50	47	46
	75	71	70
	100	95	93
	125	119	116
2/0 Copper	50	71	69
	75	106	104
	100	141	138
	125	177	173

1.0 New Unguyed Span Tensions

Table CO 168–64: New Unguyed Span Tensions: 17 kV #2 — 4/0 Copper Covered Conductor for Heavy-Loading Areas

Conductor Type	Span (ft)	Tension (lb)
#2 Copper	50	114
	75	170
	100	227
	125	283
2/0 Copper	50	139
	75	209
	100	278
	125	347
4/0 Copper	50	167
	75	250
	100	333
	125	417

2.0 Ground Clearance

Per G.O. 95, use 130°F sags when calculating conductor-to-ground clearances.

Scope CO 168.29 Sag Chart for New Reduced Tension Unguyed #6 — 1/0 Aluminum Duplex and Triplex for Heavy-Loading Areas

Table CO 168-65: Sag Chart for New Reduced Tension Unguyed #6 — 1/0 Aluminum Duplex and Triplex for Heavy-Loading Areas

Conductor Type	Span (ft)	Initial Sag	Final Sag
		50–110°F	130°F
#6 Aluminum Duplex	60	1'-6"	1'-8"
	80	2'-6"	2'-10"
	100	4'-0"	4'-6"
	120	6'-0"	6'-3"
#4 Aluminum Duplex	60	1'-0"	1'-3"
	80	1'-8"	2'-2"
	100	2'-9"	3'-3"
	120	4'-4"	4'-6"
#4 Aluminum Triplex	60	1'-0"	1'-3"
	80	2'-0"	2'-4"
	100	3'-0"	3'-6"
	120	4'-6"	4'-7"
#2 Aluminum Triplex	60	1'-0"	1'-5"
	80	2'-0"	2'-3"
	100	3'-0"	3'-6"
	120	4'-5"	4'-9"
1/0 Aluminum Triplex	60	1'-3"	1'-5"
	80	2'-0"	2'-4"
	100	3'-0"	3'-6"
	120	4'-6"	4'-8"
1/0 Aluminum Triplex	60	1'-6"	1'-8"
	80	2'-5"	2'-8"
	100	3'-8"	3'-10"
	120	5'-3"	5'-6"
4/0 Aluminum Triplex	60	1'-6"	1'-8"
	80	2'-5"	2'-8"
	100	3'-8"	3'-10"
	120	5'-3"	5'-6"

3.0 New Unguyed Span Tensions

3.1 Conductor Tensions are 75 Percent of Full Tension for 0 to 120 Feet

- Conductor tension for #6 Aluminum Duplex is 290 lb
- Conductor tension for #4 Aluminum Duplex is 453 lb
- Conductor tension for #4 Aluminum Triplex is 453 lb
- Conductor tension for #2 Aluminum Triplex is 570 lb

3.2 Conductor Tensions are 50 Percent of Full Tension for 0 to 120 Feet

- Conductor tension for 1/0 Aluminum Triplex is 707 lb

3.3 Conductor Tensions are 30 Percent of Full Tension for 0 to 120 Feet

- Conductor tension for 4/0 Aluminum Triplex is 835 lb

4.0 Ground Clearance

Per G.O. 95, use 130°F sags when calculating conductor-to-ground clearances.

Approved by: 	Reduce Tension Span Sag Charts — Directions for Use	<div style="font-size: 2em; font-weight: bold; margin: 0;">C0 168</div>
Effective Date: 01-25-2019	What's Changed?	Sheet 65 of 80 <div style="font-size: 2em; font-weight: bold; margin: 0;">DOH</div>

Scope CO 168.30 Sag Chart for New Reduced Tension Unguyed #4 — 4/0 Aluminum Quadruplex for Heavy-Loading Areas

Table CO 168–66: Sag Chart for New Reduced Tension Unguyed #4 — 4/0 Aluminum Quadruplex for Heavy-Loading Areas

Conductor Type	Span (ft)	Initial Sag	Final Sag
		50–110°F	130°F
#4 Aluminum Quadruplex	60	1'-2"	1'-6"
	80	2'-3"	2'-6"
	100	3'-6"	3'-10"
	120	5'-3"	5'-6"
#1/0 Aluminum Quadruplex	60	1'4"	1'-7"
	80	2'-2"	2'-7"
	100	3'-5"	3'-10"
	120	5'-0"	5'-5"
#4/0 Aluminum Quadruplex	60	1'-7"	1'-10"
	80	2'-0"	3'-0"
	100	4'-3"	4'-6"
	120	6'-0"	6'-3"

5.0 New Unguyed Span Tensions

- 5.1 Conductor Tensions are 75 Percent of Full Tension for 0 to 120 Feet
 - Conductor tension for #4 Aluminum Quadruplex is 453 lb
- 5.2 Conductor Tensions are 50 Percent of Full Tension for 0 to 120 Feet
 - Conductor tension for 1/0 Aluminum Quadruplex is 707 lb
- 5.3 Conductor Tensions are 30 Percent of Full Tension for 0 to 120 Feet
 - Conductor tension for 4/0 Aluminum Quadruplex is 835 lb

6.0 Ground Clearance

Per G.O. 95, use 130°F sags when calculating conductor-to-ground clearances.

Scope CO 168.31 Sag Chart for Existing and Rebuild Reduced Tension Unguyed #4 — 653 ACSR for Heavy-Loading Areas

Table CO 168–67: Sag Chart for Existing and Rebuild Reduced Tension Unguyed #4 — 653 ACSR for Heavy-Loading Areas

Conductor Type	Span (ft)	Initial Sag	Final Sag
		50–110°F	130°F
#4 ACSR ^{a/}	60	1'-3"	1'-6"
	80	2'-2"	2'-6"
	100	3'-6"	3'-7"
	120	4'-10"	5'-2"
	140	6'-10"	7'-0"
	160	8'-9"	9'-0"
#2 ACSR ^{a/}	60	1'-3"	1'-6"
	80	2'-0"	2'-4"
	100	3'-0"	3'-4"
	120	4'-5"	4'-7"
	140	5'-10"	6'-2"
	160	7'-8"	8'-0"
1/0 ACSR	60	1'-0"	1'-1"
	80	1'-2"	1'-6"
	100	1'-10"	2'-4"
	120	2'-7"	3'-0"
	140	3'-6"	4'-0"
	160	4'-7"	5'-0"
336 ACSR	60	1'-3"	1'-6"
	80	2'-0"	2'-4"
	100	2'-10"	3'-3"
	120	4'-0"	4'-5"
	140	5'-4"	5'-8"
	160	6'-8"	7'-2"
653 ACSR	60	1'-6"	1'-9"
	80	2'-3"	2'-6"
	100	3'-4"	3'-7"
	120	5'-6"	5'-8"
	140	6'-0"	6'-5"
	160	7'-10"	8'-2"

^{a/} Not approved for new construction.

Note(s):

- Use on all 2.4 kV through 33 kV systems. 36-inch minimum mid span conductor spacing depending on deviation angle may require more than 36-inch pin spacing to achieve 36-inch conductor spacing.

7.0 Existing and Rebuild Unguyed Span Tensions

7.1 Conductor Tensions are 50 Percent of Full Tension for 0 to 160 Feet

- Conductor tension for #4 ACSR is 302 lb
- Conductor tension for #2 ACSR is 380 lb
- Conductor tension for 1/0 ACSR is 707 lb

7.2 Conductor Tensions are 25 Percent of Full Tension for 0 to 160 Feet

- Conductor tension for 336 ACSR is 710 lb
- Conductor tension for 653 ACSR is 815 lb

8.0 Ground Clearance

Per G.O. 95, use 130°F sags when calculating conductor-to-ground clearances.

CO 168	Reduce Tension Span Sag Charts — Directions for Use	Approved by: <i>ajf</i>
Sheet 68 of 80	What's Changed?	Effective Date:
DOH		01-25-2019

Scope CO 168.32 Sag Chart for Existing and Rebuild Reduced Tension Unguyed 1/0 — 653 ACSR Covered Conductor for Heavy-Loading Areas

Table CO 168–68: Sag Chart for Existing and Rebuild Reduced Tension Unguyed 17 kV 1/0 — 653 ACSR Covered Conductor for Heavy-Loading Areas

Conductor Type	Span (ft)	Initial Sag	Final Sag
		50–110°F	130°F
1/0 ACSR	50	3'-9"	3'-10"
	75	5'-7"	5'-9"
	100	7'-6"	7'-7"
	125	9'-4"	9'-6"
	150	10'-10"	11'-1"
	175	12'-2"	12'-6"
336 ACSR	50	3'-9"	3'-10"
	75	5'-7"	5'-9"
	100	7'-6"	7'-8"
	125	9'-4"	9'-7"
	150	10'-10"	11'-1"
	175	12'-3"	12'-7"
653 ACSR	50	3'-9"	3'-10"
	75	5'-8"	5'-9"
	100	7'-6"	7'-8"
	125	9'-4"	9'-7"
	150	10'-10"	11'-2"
	175	12'-3"	12'-7"

Note(s):

1. Use on all 2.4 kV through 17 kV systems. 36-inch minimum mid span conductor spacing depending on deviation angle may require more than 36-inch pin spacing to achieve 36-inch conductor spacing.

Table CO 168–69: Tension Table for Existing and Rebuild Reduced Tension Unguyed 17 kV 1/0 — 653 ACSR Covered Conductor for Heavy-Loading Areas

Conductor Type	Span (ft)	Initial Tension (lb)	Final Tension (lb)
		50–110°F	130°F
1/0 ACSR	50	24	24
	75	36	36
	100	49	48
	125	61	60
	150	75	74
	175	91	89
336 ACSR	50	49	48
	75	74	72
	100	98	96
	125	123	120
	150	152	149
	175	184	179
653 ACSR	50	83	82
	75	125	123
	100	167	163
	125	208	204
	150	258	252
	175	312	304

Table CO 168–70: Sag Chart for Existing and Rebuild Reduced Tension Unguyed 35 kV 1/0 — 653 ACSR Covered Conductor for Heavy-Loading Areas

Conductor Type	Span (ft)	Initial Sag	Final Sag
		50–110°F	130°F
1/0 ACSR	50	3'-9"	3'-10"
	75	5'-7"	5'-9"
	100	7'-6"	7'-7"
	125	9'-4"	9'-6"
	150	10'-10"	11'-1"
	175	12'-2"	12'-6"
336 ACSR	50	3'-9"	3'-10"
	75	5'-7"	5'-9"
	100	7'-6"	7'-8"
	125	9'-4"	9'-7"
	150	10'-10"	11'-2"
	175	12'-3"	12'-8"
653 ACSR	50	3'-9"	3'-10"
	75	5'-8"	5'-9"
	100	7'-6"	7'-8"
	125	9'-4"	9'-7"
	150	10'-10"	11'-2"
	175	12'-3"	12'-7"

CO 168

Reduce Tension Span Sag Charts — Directions for Use

Approved by:

ajf

Sheet 70 of 80

What's Changed? Added new tension values for existing and rebuild unguyed reduced tension spans for 17 kV 1/0 — 653 ACSR CC for heavy-loading areas. Added sag values for existing and rebuild unguyed reduced tension spans for 35 kV 1/0 — 653 ACSR CC for heavy-loading areas.

Effective Date:

01-25-2019

DOH

Table CO 168–71: Tension Table for Existing and Rebuild Reduced Tension Unguyed 35 kV 1/0 — 653 ACSR Covered Conductor for Heavy-Loading Areas

Conductor Type	Span (ft)	Initial Tension (lb)	Final Tension (lb)
		50–110°F	130°F
1/0 ACSR	50	39	39
	75	59	58
	100	79	77
	125	98	96
	150	122	119
	175	147	144
336 ACSR	50	103	101
	75	137	135
	100	172	168
	125	213	207
	150	257	249
	175	303	291
653 ACSR	50	106	104
	75	159	156
	100	212	207
	125	265	259
	150	328	320
	175	397	385

Approved by:

ajf

Reduce Tension Span Sag Charts — Directions for Use

CO 168

Effective Date:
01-25-2019

What's Changed? Added new tension values for existing and rebuild unguyed reduced tension spans for 35 kV 1/0 — 653 ACSR CC for heavy-loading areas.

Sheet 71 of 80

DOH

1.0 Existing and Rebuild Unguyed Span Tensions

Table CO 168–72: Existing and Rebuild Unguyed Span Tensions: 17 kV 1/0 — 653 ACSR Covered Conductor for Heavy-Loading Areas

Conductor Type	Span (ft)	Tension (lb)
1/0 ACSR	50	119
	75	179
	100	238
	125	297
	150	368
	175	443
336 ACSR	50	160
	75	240
	100	320
	125	399
	150	495
	175	598
653 ACSR	50	210
	75	315
	100	420
	125	525
	150	651
	175	787

CO 168

Reduce Tension Span Sag Charts — Directions for Use

Approved by:



Sheet **72 of 80**

What's Changed? Updated tension values for existing and rebuild unguyed reduced tension spans for 17 kV 1/0 — 653 ACSR CC for heavy-loading areas.

Effective Date:

01-25-2019

DOH

Table CO 168–73: Existing and Rebuild Unguyed Span Tensions: 35 kV 1/0 Covered Conductor for Heavy-Loading Areas

Conductor Type	Span (ft)	Tension (lb)
1/0 ACSR	50	152
	75	228
	100	303
	125	378
	150	468
	175	564
336 ACSR	50	198
	75	296
	100	395
	125	493
	150	611
	175	738
653 ACSR	50	250
	75	375
	100	499
	125	623
	150	773
	175	934

2.0 Ground Clearance

Per G.O. 95, use 130°F sags when calculating conductor-to-ground clearances.

Scope CO 168.33 Sag Chart for Existing and Rebuild Reduced Tension Unguyed #6 — 4/0 Copper for Heavy-Loading Areas

Table CO 168–74: Sag Chart for Existing and Rebuild Reduced Tension Unguyed #6 — 4/0 Copper for Heavy-Loading Areas

Conductor Type	Span (ft)	Initial Sag	Final Sag
		50–110°F	130°F
#6 Copper ^{a/}	60	1'-6"	1'-10"
	80	2'-10"	3'-0"
	100	4'-4"	4'-6"
	120	6'-0"	6'-6"
	140	N/A ^{b/}	N/A ^{b/}
	160	N/A ^{b/}	N/A ^{b/}
#4 Copper ^{a/}	60	1'-3"	1'-6"
	80	2'-0"	2'-5"
	100	3'-2"	3'-6"
	120	4'-6"	5'-0"
	140	6'-3"	6'-7"
	160	N/A ^{b/}	N/A ^{b/}
#2 Copper ^{a/}	60	1'-0"	1'-7"
	80	1'-6"	2'-0"
	100	2'-4"	2'-9"
	120	3'-4"	3'-9"
	140	4'-6"	5'-0"
	160	5'-10"	6'-4"
2/0 Copper	60	1'-2"	1'-6"
	80	2'-0"	2'-3"
	100	2'-10"	3'-3"
	120	4'-0"	4'-6"
	140	5'-4"	5'-9"
	160	6'-10"	7'-4"
4/0 Copper	60	1'-2"	1'-6"
	80	1'-8"	2'-0"
	100	2'-5"	2'-10"
	120	3'-4"	3'-10"
	140	4'-6"	4'-10"
	160	5'-8"	6'-3"

^{a/} Not approved for new construction.

^{b/} Excessive sagging, use full tension.

Note(s):

1. Use on all 2.4 kV through 33 kV systems. 36-inch minimum mid span conductor spacing depending on deviation angle may require more than 36-inch pin spacing to achieve 36-inch conductor spacing.

3.0 Existing and Rebuild Unguyed Span Tensions

3.1 Conductor Tensions are 70 Percent of Full Tension for 60 to 160 Feet

- Conductor tension for #6 Copper is 225 lb
- Conductor tension for #4 Copper is 340 lb
- Conductor tension for #2 Copper is 533 lb

3.2 Conductor Tensions are 40 Percent of Full Tension for 60 to 160 Feet

- Conductor tension for 2/0 Copper is 593 lb

3.3 Conductor Tensions are 30 Percent of Full Tension for 60 to 160 Feet

- Conductor tension for 4/0 Copper is 915 lb

4.0 Ground Clearance

Per G.O. 95, use 130°F sags when calculating conductor-to-ground clearances.

Approved by: 	Reduce Tension Span Sag Charts — Directions for Use	C0 168
Effective Date: 01-25-2019	What's Changed?	Sheet 75 of 80 DOH

Scope CO 168.34 Sag Chart for Existing and Rebuild Reduced Tension Unguyed #2 — 4/0 Copper Covered Conductor for Heavy-Loading Areas

Table CO 168-75: Sag Chart for Existing and Rebuild Reduced Tension Unguyed 17 kV #2 — 4/0 Copper Covered Conductor for Heavy-Loading Areas

Conductor Type	Span (ft)	Initial Sag	Final Sag
		50–110°F	130°F
#2 Copper	50	3'-9"	3'-10"
	75	5'-7"	5'-9"
	100	7'-6"	7'-8"
	125	9'-4"	9'-7"
	150	10'-10"	11'-2"
	175	12'-3"	12'-7"
2/0 Copper	50	3'-9"	3'-10"
	75	5'-7"	5'-9"
	100	7'-6"	7'-8"
	125	9'-4"	9'-7"
	150	10'-10"	11'-2"
	175	12'-3"	12'-7"
4/0 Copper	50	3'-9"	3'-10"
	75	5'-7"	5'-9"
	100	7'-6"	7'-8"
	125	9'-4"	9'-7"
	150	10'-10"	11'-2"
	175	12'-3"	12'-7"

Note(s):

- Use on all 2.4 kV through 17 kV systems. 36-inch minimum mid span conductor spacing depending on deviation angle may require more than 36-inch pin spacing to achieve 36-inch conductor spacing.

Table CO 168–76: Tension Table for Existing and Rebuild Reduced Tension Unguyed 17 kV #2 — 4/0 Copper Covered Conductor for Heavy-Loading Areas

Conductor Type	Span (ft)	Initial Tension (lb)	Final Tension (lb)
		50–110°F	130°F
#2 Copper	50	27	26
	75	41	40
	100	54	53
	125	68	66
	150	84	82
	175	101	99
2/0 Copper	50	47	46
	75	71	70
	100	95	93
	125	119	116
	150	147	144
	175	177	173
4/0 Copper	50	71	69
	75	106	104
	100	141	138
	125	177	173
	150	219	214
	175	264	258

1.0 Existing and Rebuild Unguyed Span Tensions

Table CO 168–77: Existing and Rebuild Unguyed Span Tensions: 17 kV #2 — 4/0 Copper Covered Conductor for Heavy-Loading Areas

Conductor Type	Span (ft)	Tension (lb)
#2 Copper	50	114
	75	170
	100	227
	125	283
	150	350
	175	422
2/0 Copper	50	139
	75	209
	100	278
	125	347
	150	430
	175	519
4/0 Copper	50	167
	75	250
	100	333
	125	417
	150	517
	175	624

2.0 Ground Clearance

Per G.O. 95, use 130°F sags when calculating conductor-to-ground clearances.

Scope CO 168.35 Sag Chart for Existing and Rebuild Reduced Tension Unguyed #6 — 4/0 Aluminum Duplex and Triplex for Heavy-Loading Areas

Table CO 168-78: Sag Chart for Existing and Rebuild Reduced Tension Unguyed #6 — 4/0 Aluminum Duplex and Triplex for Heavy-Loading Areas

Conductor Type	Span (ft)	Initial Sag	Final Sag
		50-110°F	130°F
#6 Aluminum Duplex	60	1'-6"	1'-8"
	80	2'-6"	2'-10"
	100	4'-0"	4'-6"
	120	6'-0"	6'-3"
	140	8'-3"	8'-6"
	160	11'-0"	11'-1"
#4 Aluminum Duplex	60	1'-0"	1'-3"
	80	1'-8"	2'-2"
	100	2'-9"	3'-3"
	120	4'-4"	4'-6"
	140	5'-10"	6'-3"
	160	7'-6"	8'-0"
#4 Aluminum Triplex	60	1'-0"	1'-3"
	80	2'-0"	2'-4"
	100	3'-0"	3'-6"
	120	4'-6"	4'-7"
	140	6'-5"	6'-8"
	160	8'-6"	8'-9"
#2 Aluminum Triplex	60	1'-0"	1'-5"
	80	2'-0"	2'-3"
	100	3'-0"	3'-6"
	120	4'-5"	4'-9"
	140	6'-0"	6'-4"
	160	7'-10"	8'-3"
1/0 Aluminum Triplex	60	1'-3"	1'-5"
	80	2'-0"	2'-4"
	100	3'-0"	3'-6"
	120	4'-6"	4'-8"
	140	6'-10"	6'-4"
	160	7'-9"	8'-3"
4/0 Aluminum Triplex	60	1'-6"	1'-8"
	80	2'-5"	2'-8"
	100	3'-8"	3'-10"
	120	5'-3"	5'-6"
	140	7'-0"	7'-4"
	160	9'-0"	9'-6"

Approved by:
ajf

Reduce Tension Span Sag Charts — Directions for Use

CO 168

Effective Date:
01-25-2019

What's Changed?

Sheet 79 of 80

DOH

3.0 Existing and Rebuild Unguyed Span Tensions

3.1 Conductor Tensions are 75 Percent of Full Tension for 0 to 160 Feet

- Conductor tension for #6 Aluminum Duplex is 290 lb
- Conductor tension for #4 Aluminum Duplex is 453 lb
- Conductor tension for #4 Aluminum Triplex is 453 lb
- Conductor tension for #2 Aluminum Triplex is 570 lb

3.2 Conductor Tensions are 50 Percent of Full Tension for 0 to 160 Feet

- Conductor tension for 1/0 Aluminum Triplex is 707 lb

3.3 Conductor Tensions are 30 Percent of Full Tension for 0 to 160 Feet

- Conductor tension for 4/0 Aluminum Triplex is 835 lb

4.0 Ground Clearance

Per G.O. 95, use 130°F sags when calculating conductor-to-ground clearances.

CO 168	Reduce Tension Span Sag Charts — Directions for Use	Approved by: <i>ajf</i>
Sheet 80 of 80	What's Changed?	Effective Date:
DOH		01-25-2019

CO 300 Copper-to-Copper Connectors

Scope CO 300.1 Copper-to-Copper Connectors

1.0 Split Bolts

1.1 Application

All secondary, 2.4 kV, 4 kV, and 7 kV, copper-to-copper connections, in non-high fire areas.

Material:

**Table CO 300–1: Split Bolts
(Copper-to-Copper Connections Only)**

Equal Size Run and Tap		MIN Tap with MAX Cable Run	SAP
MIN	MAX		
#10 Str.	#8 Str.	#14 Str.	10111553
#8 Str.	#6 SOL	#14 Str.	10111554
#8 Str.	#4 SOL	#14 Str.	10111555
#6 Str.	#2 SOL	#14 Str.	10111556
#6 Str.	#2 Str.	#14 Str.	10111557
#2 Str.	2/0 Str.	#14 Str.	10111559

Figure CO 300–1: Split Bolts



2.0 Two Bolt

2.1 Application

All secondary, 2.4 kV, 4 kV, and 7 kV, copper-to-copper connections, in non-high fire areas.

Material:

Table CO 300–2: Two Bolts

Copper-to-Copper Connections Only				
Run		Tap		SAP
MIN	MAX	MIN	MAX	
#2 Str.	2/0 Str.	#6 Str.	2/0 Str.	10111579
1/0 Str.	4/0 Str.	#6 Str.	4/0 Str.	10111580
4/0 Str.	350 kcmil	#4 Str.	350 kcmil	10111581
400 kcmil	500 kcmil	#4 Str.	500 kcmil	10111582
600 kcmil	800 kcmil	3/0 Str.	800 kcmil	10111583
750 kcmil	1000 kcmil	3/0 Str.	1000 kcmil	10111584

Figure CO 300–2: Two Bolt



CO 300

Copper-to-Copper Connectors

Approved by:

ajf

Sheet 2 of 4

What's Changed? Updated Section 2.1 for clarity and updated Figure CO 300-2 with new image.

Effective Date:

01-25-2019

DOH

3.0 Vise Type

3.1 Application

All distribution voltages, copper-to-copper connections in non-high fire areas.

Material:

**Table CO 300–3: Vise Type
(Copper-to-Copper Connections Only)**

Solid	Stranded	SAP
#4	#4	10111595
#1	#2	10111602
3/0	2/0	10111603
4/0	4/0	10111604

Figure CO 300–3: Vise Type



4.0 Parallel Groove

4.1 Application

Copper-to-copper connections in fire-hazard areas.

Material:

**Table CO 300–4: Parallel Groove
(Copper-to-Copper Connections Only)**

Run		Tap		SAP
MIN	MAX	MIN	MAX	
#6	4/0 Str.	#6	4/0 Str.	10111472

Figure CO 300–4: Parallel Groove



Approved by:

ajf

Copper-to-Copper Connectors

CO 300

Effective Date:
01-25-2019

What's Changed? Updated Section 3.1 for clarity and updated Figure CO 300-3 and Figure CO 300-4 with new image. Table CO 300-4 was updated for clarity.

Sheet 3 of 4

DOH

5.0 Hot Line Clamp

5.1 Application

Hot line clamps are for primary distribution tap connections where up to 200 A (maximum) of load is expected on a piece of equipment, overhead tap line or underground riser. Applications may include fire hazard areas as clearing around the structures is not required (that is, exempt by California Department of Forestry).

Typical applications:

- Capacitor banks
- Transformers and transformer banks
- Overhead tap lines, 200 A maximum
- Underground risers 200 A maximum

Applications where hot line clamps should not be utilized:

- Overhead main line to main line connections (overhead backbone)
- Overhead to underground main line risers

Material:

**Table CO 300–5: Hot Line Clamp
(Copper-to-Copper Connections Only)**

Conductor Range				
Copper		Copper		SAP
Run		Tap		
MIN	MAX	MIN	MAX	
#8 SOL	2/0 Str.	#8 SOL	2/0 Str.	10111542 ^{a/b/}
#6 SOL	400	#6 SOL	4/0 Str.	10111543 ^{b/}

^{a/} Figure CO 300–5: Hot Line Clamp

^{b/} Clamp uses 11/16 inch tap nut.

Figure CO 300–5: Hot Line Clamp



CO 305 Connectors — Copper-to-Aluminum and Aluminum-to-Aluminum

Scope CO 305.1 Connectors — Copper-to-Aluminum and Aluminum-to-Aluminum

1.0 Connectors — Copper-to-Aluminum and Aluminum-to-Aluminum

Figure CO 305–1: Insulated Service Sleeves



Table CO 305–1: Insulated Service Sleeves

Service Conductor		Customer's Conductors			SAP	Crimps Per End	
Aluminum	Color Code	Copper		Color Code		OH-25	MD-6
		Solid	Strand				
#6 Solid	Green	#8	#10	Brown	10112111	1	3
#6 Solid	Green	#6	#8	Green	10112112	1	3
#6 Solid	Green	#4	#5 & 6	Blue	10112114	1	3
#6 Solid	Green	#2	#3 & 4	Orange	10112116	1	3
#6 Solid	Green	—	#1 & 2	Red	10112118	1	3
#6 Solid	Green	—	1/0	Yellow	10112119	1	3
#6 Str. or ACSR	Blue	#8	#10	Brown	10112113	1	3
#6 Str. or ACSR	Blue	#4	#5 & 6	Blue	10112115	1	3
#6 Str. or ACSR	Blue	—	#1 & 2	Red	10112120	1	3
#6 Str. or ACSR	Blue	—	1/0	Yellow	10112121	1	3
#4 Str. or ACSR	Orange	#8	#10	Brown	10112110	1	3
#4 Str. or ACSR	Orange	#4	#5 & 6	Blue	10112117	1	3
#4 Str. or ACSR	Orange	#2	#3 & 4	Orange	10112122	1	3
#4 Str. or ACSR	Orange	—	1/0	Yellow	10112123	1	3
#1 & 2 Str. or ACSR	Red	#8	#10	Brown	10112126	1	3
#1 & 2 Str. or ACSR	Red	#2	#3 & 4	Orange	10112124	1	3
#1 & 2 Str. or ACSR	Red	—	#1 & 2	Red	10112125	1	3
#1 & 2 Str. or ACSR	Red	—	1/0	Yellow	10112127	1	3
1/0 Str. or ACSR	Yellow	—	1/0	Yellow	10112128	1	3

Approved by:

ajt

Connectors — Copper-to-Aluminum and Aluminum-to-Aluminum

CO 305

Effective Date:
01-25-2019

What's Changed? Updated Figure CO 305-1 with new image.

Sheet 1 of 5

DOH

1.1 Application

- A. Load end of triplex or quadruplex service conductors #6 through 1/0.
- B. Pole top on a pole with a single service.
- C. Due to the inrush of large 3Ø motors and pumps, the use of insulated service sleeves is restricted to the maximum horsepower as listed in the table below:

Table CO 305–2: Maximum 3-Phase Horsepower Rating Using Insulated Service Sleeve Connectors

Size Quadruplex (AWG)	Current Capacity (A)	Maximum 3Ø Horsepower Rating Using Insulated Service Sleeve Connectors		
		208 V	240 V	480 V
#4	100	15	15	30
1/0	180	20	20	50

Note(s):

- 1. Install with a mechanical compression tool.
- 2. DO NOT USE on UNINSULATED conductors.
- 3. This IS NOT a tension splice.

1.2 Approved Tools:

- A. Burndy OH-25 Hand Tool (SAP 10148823)
- B. Burndy MD-6 (SAP 10148818)

2.0 Parallel Groove

Figure CO 305–2: Parallel Groove



2.1 Application

Secondary line connections.

All 2.4 kV through 33 kV connections.

Table CO 305–3: Parallel Groove

Conductor Range					
Number Bolts	Run		Tap		SAP
	ACSR	Al or Cu	ACSR	Al or Cu	
1 ^{a/}	#6 - 1/0	#8 - 1/0	#6 - 1/0	#8 - 1/0	10112373
1	#6 - 2/0	#6 SOL - 2/0 Str.	#6 - 2/0	#6 SOL - 2/0 Str.	10112370
1	#6 - 2/0 (6/1)	#6 SOL - 3/0 Str.	#6 - 2/0 (6/1)	#6 SOL - 3/0 Str.	10112357
1	3/0 - 397.5 18/1	3/0 - 400	#6 - 2/0	#6 SOL - 2/0 Str.	10112369
3	3/0 - 397.5 18/1	3/0 - 400	3/0 - 397.5 18/1	3/0 - 400	10112368
1	397.5 18/1 - 795 26/7	450 - 1000	#6 - 2/0	#6 SOL - 2/0 Str.	10112374
2	397.5 18/1 - 795 26/7	450 - 1000	3/0 - 397.5 18.1	3/0 - 400	10112371
3	397.5 18/1 - 795 26/7	450 - 1000	397.5 18/1 - 795 26/7	450 - 1000	10112372

^{a/} To be used on 0–5,000 V only.

Approved by: <i>ajt</i>	Connectors — Copper-to-Aluminum and Aluminum-to-Aluminum	CO 305
Effective Date: 01-25-2019	What's Changed? Updated Figure CO 305-2 with new image.	Sheet 3 of 5
		DOH

3.0 Two-Bolt

Figure CO 305-3: Two-Bolt



3.1 Application

All 2.4 kV through 7 kV connections except on #4 ACSR.

Secondary connections larger than 4/0 all-aluminum or 4/0 ACSR.

Table CO 305-4: Two Bolts

Conductor								
Copper and Aluminum				ACSR				SAP
Run		Tap		Run		Tap		
MIN	MAX	MIN	MAX	MIN	MAX	MIN	MAX	
#2 Str.	2/0 Str.	#10 Str.	2/0 Str.	#3 Str.	1/0 Str.	#6 Str.	1/0 Str.	10112425
1/0 Str.	4/0 Str.	#10 Str.	4/0 Str.	1/0 Str.	4/0 Str.	#6 Str.	4/0 Str.	10112426
400 kcmil	500 kcmil	#4 Str.	500 kcmil	336.4 kcmil	397.5 kcmil	#5 Str.	397.5 kcmil	10112427
400 kcmil	800 kcmil	3/0 Str.	800 kcmil	336.4 kcmil	715.5 kcmil	3/0 Str.	715.5 kcmil	10112428
500 kcmil	1000 kcmil	3/0 Str.	1000 kcmil	397.5 kcmil	900 kcmil	3/0 Str.	900 kcmil	10112429

CO 305 Sheet 4 of 5 DOH	Connectors — Copper-to-Aluminum and Aluminum-to-Aluminum	Approved by: 
	What's Changed? Updated Figure CO 305-3 with new image.	Effective Date: 01-25-2019

4.0 Hot Line Clamp

Figure CO 305–4: Hot Line Clamp



4.1 Application

Hot line clamps are for primary distribution tap connections where up to 200 A (maximum) of load is expected on a piece of equipment, overhead tap line or underground riser. Applications may include fire hazard areas as clearing around the structures is not required (that is, exempt by California Department of Forestry).

Typical applications:

- Capacitor banks
- Transformers and transformer banks
- Overhead tap lines, 200 A maximum
- Underground risers, 200 A maximum

Should not be used on:

- Overhead main line to main line connections (overhead backbone)
- Overhead to underground main line risers

Material:

**Table CO 305–5: Hot Line Clamp
(Copper to Aluminum and Aluminum to Aluminum Connections)**

Conductor Range				
ACSR		ACSR (Aluminum)/Copper		SAP
Run		Tap		
MIN	MAX	MIN	MAX	
#8	2/0 Str.	#8	1/0	10111541 ^{a/}
#6	397.5	#6	3/0	10111539 ^{b/c/}
556.5	954	#6	266.8	10111540 ^{a/}

^{a/} Clamp uses 11/16 inch tap nut.

^{b/} [Figure CO 305–4](#): Hot Line Clamp

^{c/} Clamp uses 3/4 inch tap nut.

Approved by:

ajf

Connectors — Copper-to-Aluminum and Aluminum-to-Aluminum

CO 305

Effective Date:
01-25-2019

What's Changed? Updated Figure CO 305-3 with new image.

Sheet 5 of 5

DOH

This page intentionally left blank.

CO 410 Compression Splices

Scope CO 410.1 Tool and Die List for Full Tension Compression Splices

1.0 Tool and Die List for Copper Full Tension Compression Splice

Figure CO 410–1: Copper Full Tension Compression Splice



1.1 Application

To be used on copper conductors of all distribution voltages.

Table CO 410–1: Copper Full Tension Compression Splice

Wire Size	Splice SAP	MD-6 Die Number and SAP	Y34A Die Number and SAP	Y35-Y39-12HA Die Number and SAP	UT-15 Die Number and SAP	Number of Crimps per End
#8 SOL	10110772	W-161 10148858	N/A	N/A	N/A	1
#6 SOL	10110773	W-161 10148858	N/A	N/A	N/A	2
#4 SOL	10110774	W-162 10148861	N/A	N/A	N/A	5
#2 SOL	10110775	W-163 10148862	N/A	N/A	N/A	5
#4-7 Str.	10110776	W-162 10148861	N/A	N/A	N/A	5
#2-7 Str.	10110778	W-163 10148862	N/A	N/A	N/A	5
2/0 Str.	10110779	W-166 10148863	A166/A26YD 10148874	U-166 10148878	U-166 10148878	MD6=12 Others=6
4/0 Str.	10110781	N/A	A168/A28YD 10148875	U-168 10148880	U-168 10148880	9

Note(s):

1. Use adapter die SAP 10148852 to fit Y35, Y39, or 12HA dies in UT-15 tool.
2. Use adapter die SAP 10148851 to fit Y34A dies in UT-15 tool.

Approved by: <i>ajf</i>	Compression Splices	CO 410
Effective Date: 01-25-2019	What's Changed? Updated Figure CO 410-1 with new image and updated Table CO 410-1.	Sheet 1 of 9
		DOH

2.0 Tool and Die List for All Aluminum Full Tension Compression Splice

Figure CO 410–2: All Aluminum Full Tension Compression Splice



2.1 Application

Full tension splicing.

Table CO 410–2: All Aluminum Full Tension Compression Splice

Wire Size	Splice SAP	MD-6 Die Number and SAP	Y34A Die Number and SAP	Y35-Y39-12HA Die Number and SAP	UT-15 Die Number and SAP	Number of Crimps per End
#6 SOL	10112143	W-161 10148858	N/A	N/A	N/A	2
#6-7 Str.	10112144	W-161 10148858	N/A	N/A	N/A	2
#4-7 Str.	10112145	W-162 10148861	N/A	N/A	N/A	4
#2-7 Str.	10112146	W-163 10148862	N/A	N/A	N/A	5
#1/0-7 Str.	10112147	BG 10148818	N/A	N/A	N/A	8
4/0 7 Str.	10112148	N/A	A249 10148887	U-249 10148909	See Note 1 See Note 2	6
477 kcmil	10111998	N/A	N/A	15CA106H 10148853	See Note 1	Overlap

Note(s):

1. Use adapter die SAP 10148852 to fit Y35, Y39, or 12HA dies in UT-15 tool.
2. Use adapter die SAP 10148851 to fit Y34A dies in UT-15 tool.

Scope CO 410.2 Tool and Die List for Full and Partial Tension Compression Splices

1.0 Tool and Die List for ACSR Full and Partial Tension Compression Splices (Single Sleeve)

Figure CO 410-3: ACSR Full Tension Compression Splice (Single Sleeve)



1.1 Application

May be used on distribution voltages.

Table CO 410-3: ACSR Full and Partial Tension Compression Splices (Single Sleeve)

Wire Size	Splice SAP	MD-6 Die Number and SAP	Y34A Die Number and SAP	Y35-Y39-12HA Die Number and SAP	UT-15 Die Number and SAP	Number of Crimps per End
#4 (6/1)	10112090	W-687 10148864	N/A	U-243 10148908	See Note 1	MD6=12 Others=6
#2 (6/1)	10112091	W-687 10148864	N/A	U-243 10148908	See Note 1	MD6=14 Others=7
1/0 (6/1)	10112092	W-702 10148865	N/A	U-247 10148910	See Note 1	MD6=14 Others=7
2/0 (6/1)	10112093	N/A	N/A	U-659 10148911	See Note 1	Overlap
4/0 (6/1)	10112094	N/A	N/A	U-654 10148912	See Note 1	Overlap
336.4 kcmil (18/1)	10112095	N/A	N/A	U-655 10148913	See Note 1	Overlap
653.9 kcmil (18/3)	10112096	N/A	N/A	N/A	15C140R 10148896 See Note 2	22

Note(s):

1. Use adapter die SAP 10148852 to fit Y35, Y39, or 12HA dies in UT-15 tool.
2. Partial Tension Splice, 93 percent Rated Breaking Strength, (RBS), or 13,800 lb.

Approved by:

ajf

Compression Splices

CO 410

Sheet 3 of 9

Effective Date:
01-25-2019

What's Changed? Updated Figure CO 410-3 with new image and updated Table CO 410-3.
Added Note 2.

DOH

2.0 Tool and Die List for All Aluminum Partial Tension Compression Splice for Use on Aluminum or ACSR (Services/Jumpers)

Figure CO 410-4: All Aluminum Compression Splice for Use on Aluminum or ACSR-Partial Tension (Services/Jumpers)



2.1 Application

May be used on all distribution voltages.

Table CO 410-4: All Aluminum Partial Tension Compression Splice for Use on Aluminum or ACSR (Services/Jumpers)

Wire Size	Splice SAP	MD-6 Die Number and SAP	Y34A Die Number and SAP	Y35-Y39-12HA Die Number and SAP	UT-15 Die Number and SAP	Number of Crimps per End
#6 (6/1)	10112129	W-162 10148861	N/A	N/A	N/A	2
#4 (6/1)	10112130	W-162 10148861	N/A	N/A	N/A	4
#4 (6/1)	10112005	W-687 10148864	N/A	U-243 10148908	See Note 1	3
1/0 (6/1)	10112007	W-702 10148865	N/A	U-247 10148910	See Note 1	MD6=4 Others=3

Note(s):

1. Use adapter die SAP 10148852 to fit Y35, Y39, or 12HA dies in UT-15 tool.

CO 410

Compression Splices

Approved by:

ajf

Sheet 4 of 9

What's Changed? Updated Figure CO 410-4 with new image and updated Table CO 410-4.

Effective Date:

DOH

01-25-2019

Scope CO 410.3 Instructions for Installing Full Tension, Double-Sleeve, Compression Splices for ACSR Conductors

1.0 Instructions for Installing Full Tension, Double-Sleeve, Compression Splices for ACSR Conductors

Figure CO 410-5: Instructions for Installing Full Tension, Double-Sleeve, Compression Splices for ACSR Conductors

To be installed on de-energized conductors only.

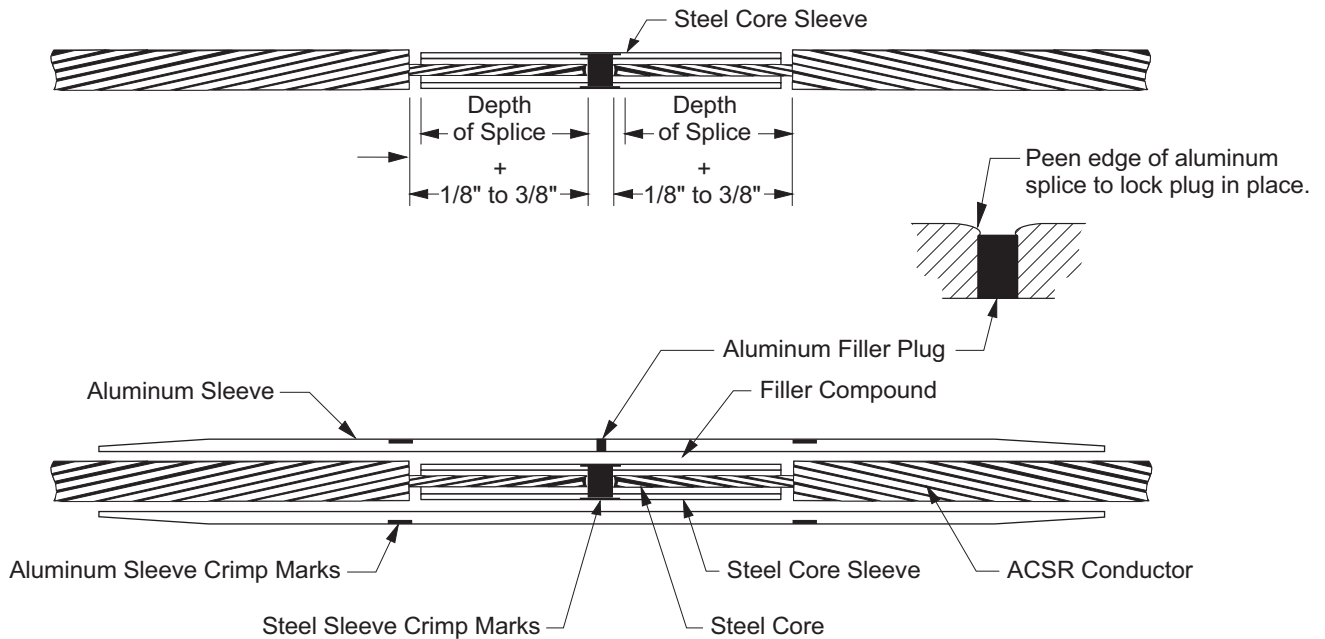

Table CO 410-5: Instructions for Installing Full Tension, Double-Sleeve, Compression Splices for ACSR Conductors

Conductor Size	SAP	Sleeve	Die SAP	UT-15	Y35-39
336.4-30x7	10112041	Aluminum Sleeve	10148918 10148917	B20AH-14AH ^{a/} B105H ^{a/}	B20AH-14AH B10SH

^{a/} May be used in UT-15 with adapter die SAP 10148852.

Note(s):

- Surfaces of the conductor shall be cleaned of all foreign matter before splicing. Use a wire brush before applying a coat of filler compound (SAP 10064145).
- The ends of conductor strands shall be examined for defects (burrs, nicks, and so forth) and the strands shall be counted to verify that they have the correct number for the subject conductor. The conductor ends shall be cut beyond any damaged or missing strands; The aluminum sleeve shall be thoroughly cleaned inside and out before it is slipped over the conductor ends.

Approved by: <i>ajf</i>	Compression Splices	CO 410
Effective Date: 01-25-2019	What's Changed?	
		DOH

3. Loose strands shall be tightened by having the outer layer twisted in the direction of the lay, and shall be bound with binding wire along the entire length over which strands have been tightened so as to prevent unravelling.
4. To allow for elongation of the steel sleeve during crimping, the aluminum strands shall be removed to a point not more than 3/8 inch nor less than 1/8 inch beyond the ends of the steel core sleeve.
5. The outer layers of aluminum strands shall be cut using a hack saw or an approved cable cutting tool. The inner layer shall be nicked only, with cutting completed by breaking the strands. The saw shall not touch the steel core. All cuts shall be square when finished.
6. The ends of the steel core shall be centered in the steel core sleeve with all binding removed from the steel core.
7. On Alcoa and Fargo steel core splices, pressing shall start adjacent to the center mark on each sleeve and continue to the ends leaving no space between presses.
8. The correct die shall be selected each time by matching the index numbers stamped on both the sleeve and die set.
9. After the wire binding has been removed from the aluminum strands, the aluminum sleeve shall be centered over the steel sleeve. Any looseness in the strands shall be worked into the sleeve and the conductor tightly bound with wire just outside each sleeve end. A double check shall be made of the correct position of the aluminum sleeve over the core splice by marking with tape the points where the ends of the sleeve should fall.
10. Before pressing, the space between the steel and aluminum sleeves shall be filled with filler compound using a caulking gun. Grease shall be forced into the filling hole until it comes out at each end of the sleeve. Using a hammer and punch, the aluminum plug shall then be driven into the fill hole and locked in place by peening the edge of the hole opening over it.
11. On Alcoa and Fargo splices, pressing of the aluminum sleeve shall start at the ends of the steel core (at the marks on sleeve) and continue toward the ends. Pressing shall be continuous, leaving no space between presses.
12. Should there be any indication of the splice bending during pressing operations, the press shall be reversed in direction for each compression.
13. At the completion of pressing operations, all wrapping, binding, and excess grease shall be removed.
14. The conductor strands shall be snugly seated after the splice is completed. Slight bends in the splice can be removed with a hammer, by using a hardwood block above and below the splice to protect the splice from direct blows of the hammer.
15. A parallel groove clamp may be substituted wherever wire binding is specified.

CO 410	Compression Splices	Approved by: <i>ajf</i>
Sheet 6 of 9	What's Changed?	Effective Date:
DOH		01-25-2019

Scope CO 410.4 ACSR Repair Splice for #4, 1/0, and 336.4 ACSR

1.0 ACSR Repair Splice for #4, 1/0, and 336.4 ACSR

Figure CO 410-6: ACSR Repair Splice for #4, 1/0, and 336.4 ACSR



1.1 Application

Used to repair damaged #4, 1/0, and 336.4 ACSR conductors. The U-shaped splice completely encloses all strands and restores full load rating to Al/ACSR conductors with burned or mechanically damaged strands. The splice is not to be used on conductors where the steel core of an ACSR conductor has been damaged, or where more than 1/3 of the conductor strands have been damaged.

The splice is designed to be applied without cutting the conductor (requiring bypasses, wire grips or hot hoists).

1.2 Installation

- A. Inspect the damaged conductor. The steel core must be undamaged and no more than 1/3 of the conductor strands damaged.



- B. Select the splice, correct die, and the crimping tool from the table.

Conductor Size	SAP	Length (in)	Die	
			MD-6	12HA, UT-15, Y-35
#4 ACSR	10111822	7	W-163	U-163
1/0 ACSR	10111823	8	W-165, W-166	U-165, U-166
336.4 ACSR	10111824	12	—	U-655

- C. Reseat the damaged strands to the line. This may take a little time and may involve trimming a few strands. Damage to the conductor (including any necessary trimming) must not exceed 1 inch in length.



D. Properly clean and grease conductor. This step is very important to ensure a good electrical splice.



E. Install splice — generally install the U-shaped splice on top of the conductor and center on the damaged area, so that the open side of the splice is pointed down. A duckbill ground clamp is used to install the splice onto the conductor.

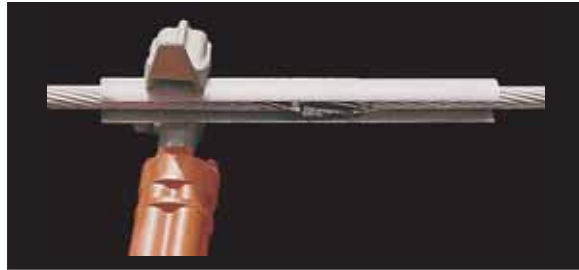

F. Position the splice so that the opened side of the splice is pointing towards the upper or lower die. Do not install the splice so that the opened side of the splice is pointing towards the seam between the upper and lower die.

G. Start crimps at center of splice, working towards each end. Space each crimp approximately 1/16 inch–1/8 inch apart. It is not necessary to rotate crimps around the splice while crimping.

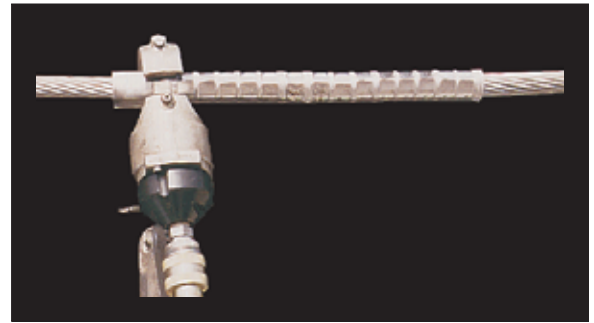

H. Finished splice.



Approved by: 	Compression Splices	CO 410
Effective Date: 01-25-2019	What's Changed?	Sheet 9 of 9 DOH

This page intentionally left blank.

CO 460 Installation Procedures for Spiral Vibration Dampers

Scope CO 460.1 Installation Procedures for Spiral Vibration Dampers

Figure 460–1: Spiral Vibration Dampers



1.0 Application

Use of the Spiral Vibration Dampers is intended to reduce Aeolian vibration (high frequency, low amplitude vibration) caused by wind blowing across overhead conductors. Aeolian vibration is generally produced by wind velocities below 15 MPH. Spiral Vibration Dampers shall be installed on spans 300 feet or greater for new construction or during planned maintenance activities. Spiral vibration dampers are not placement specific and may be installed on either end of the span.

Dampers are not generally needed in heavy loading areas, due to low conductor tensions when no ice is on the conductor. They are not needed for use on covered conductor.

Table CO 460–1: SAP Numbers and Applicable Conductor Sizes

SAP	Applicable Conductor Size
10068551	#6 ACSR (Turkey) #4 Cu
10068553	#4 ACSR (Swan) #2 ACSR (Sparrow) #2 Cu
10068554	1/0 ACSR (Raven) 2/0 Cu
10068555	4/0 ACSR (Penguin) 4/0 Cu
10068556	336 ACSR (Merlin and Oriole)

Note(s):

- For conductor sizes larger than 336 ACSR, transmission style stock-bridge dampers should be considered. Contact Transmission Engineering.

Approved by: <i>ajf</i>	Installation Procedures for Spiral Vibration Dampers	CO 460
Effective Date: 01-25-2019	What's Changed? Initial issue.	Sheet 1 of 3
		DOH

2.0 Installation

- STEP 1. Choose the Spiral Vibration Damper that fits the conductor it will be installed on (see [Table CO 460-1](#)).
- STEP 2. Inspect the conductor for strand damage and, if present, determine whether the Spiral Vibration Damper can be installed beyond the damaged area. If the conductor is in good shape proceed to Step 3.
- STEP 3. Install the spiral vibration damper onto the conductor by wrapping one side of the gripping section onto the conductor in a clockwise fashion. Maintain a minimum of 6 inches from dead-end or insulator conductor clamp.
- STEP 4. Continue wrapping the damping section clockwise as well.
- STEP 5. Make sure the damper is properly seated on the conductor at both ends.
- STEP 6. A maximum of three Spiral Vibration Dampers can be interlaced, forming a subset, if setting 6 inches apart is not achievable (see [Figure 460-3](#)).

Figure 460-2: Complete Installation of Vibration Dampers



Figure 460-2.1: Two Vibration Dampers Per Conductor — Span Length 300'–800'

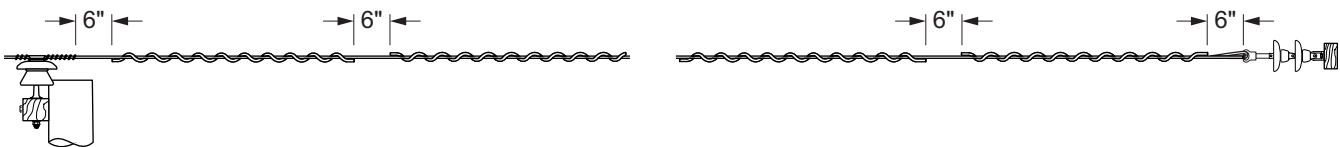

Figure 460-2.2: Four Vibration Dampers Per Conductor — Span Length 801'–2,400'



NOTE

Treat suspension construction the same as pin and insulator.

Figure 460–3: Spiral Vibration Damper Subset



Note(s):

1. Up to three dampers can interlaced to form a subset for conductor sizes up to 1/0 ACSR or 2/0 Cu. For conductors larger than 1/0 ACSR or 2/0 Cu, only two dampers may be interlaced to form a subset.

Approved by: 	Installation Procedures for Spiral Vibration Dampers	CO 460
Effective Date: 01-25-2019	What's Changed? Initial issue.	Sheet 3 of 3 DOH

This page intentionally left blank.

CO 700 Span Lengths, Minimum Conductor Spacing, Composite and Wood Crossarm Pre-Drilled Holes

Scope CO 700.1 Span Lengths and Minimum Conductor Spacing

Table CO 700-1: Span Lengths and Minimum Conductor Spacing

Span in Length (ft)	Minimum Conductor Spacing (in)
0 to 150	13-1/4
151 to 205	19-7/8
206 to 305	27-3/4
306 to 440	32
441 to 500	39-3/4
501 to 660	48

Approved by: <i>ajf</i>	Span Lengths, Minimum Conductor Spacing, Composite and Wood Crossarm Pre-Drilled Holes	CO 700
Effective Date: 01-25-2019	What's Changed?	Sheet 1 of 12
		DOH

Scope CO 700.2 Composite Crossarm Pre-Drilled Holes

Figure CO 700-1: 5' Dead-End Composite Crossarm Pre-Drilled Holes (SAP 10211425)

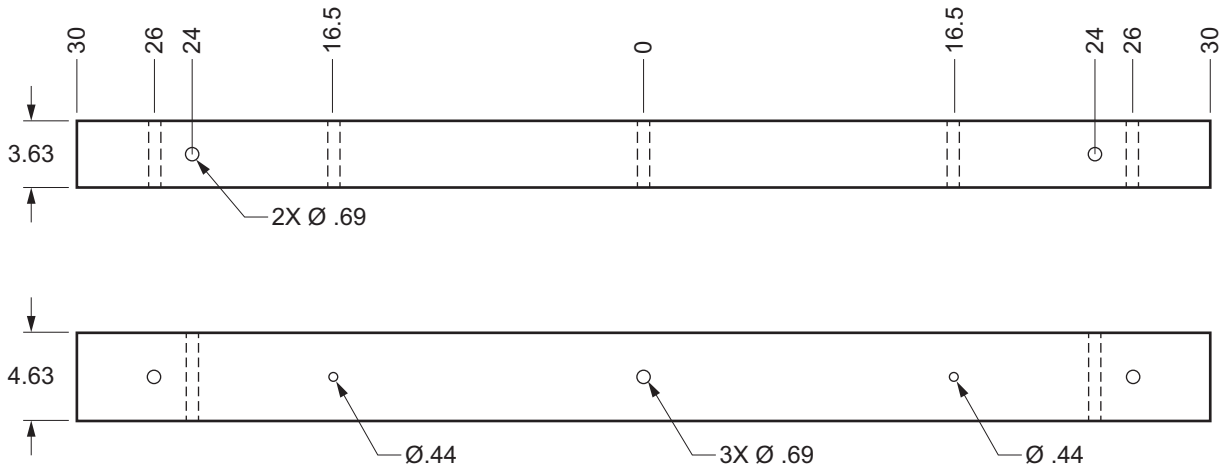

Figure CO 700-2: 8' Dead-End Composite Crossarm Pre-Drilled Holes (SAP 10060796)

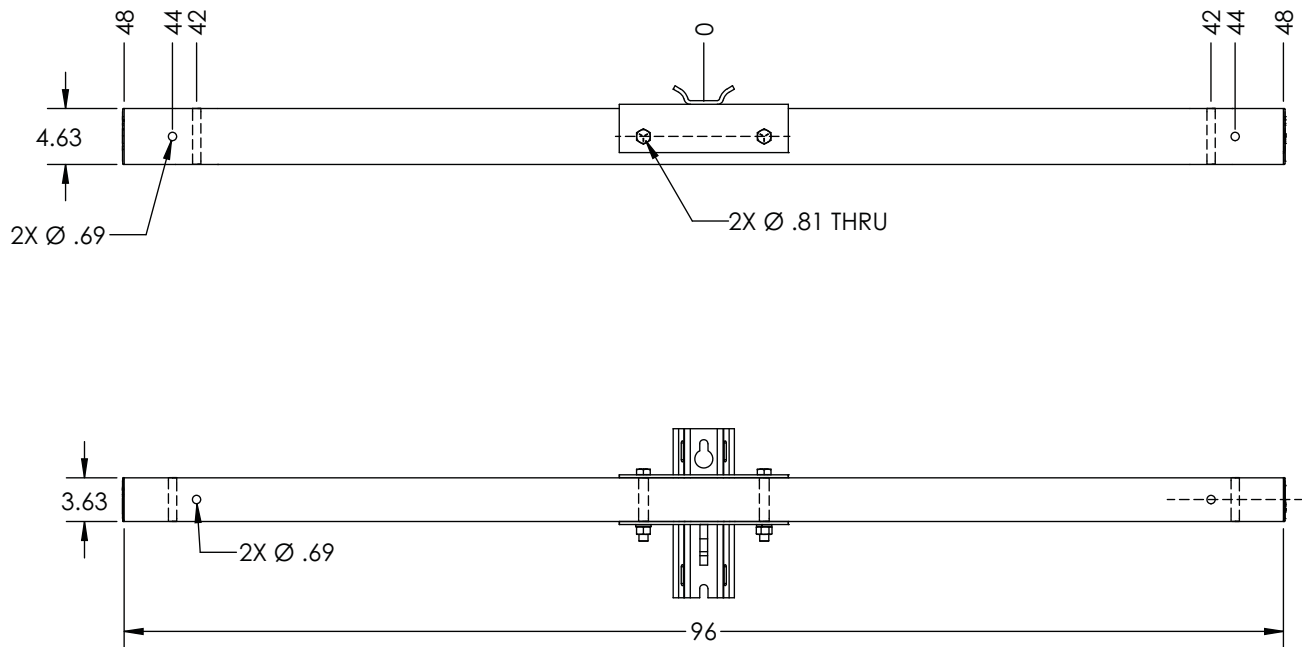
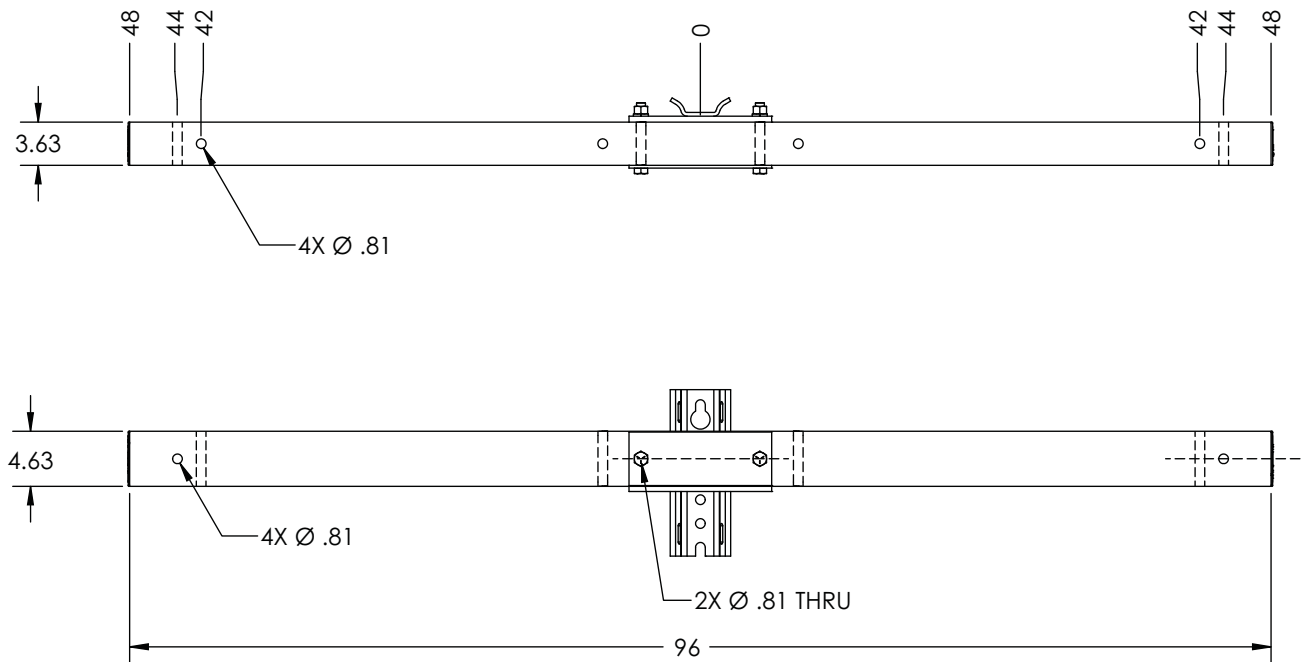

Figure CO 700-3: 8' Tangent Composite Crossarm Pre-Drilled Holes (SAP 10060793)



Approved by:

ajf

Span Lengths, Minimum Conductor Spacing, Composite and Wood Crossarm Pre-Drilled Holes

CO 700

Effective Date:

01-25-2019

What's Changed?

Sheet 3 of 12

DOH

Figure CO 700-4: 10' Dead-End Composite Crossarm Pre-Drilled Holes (SAP 10600797)

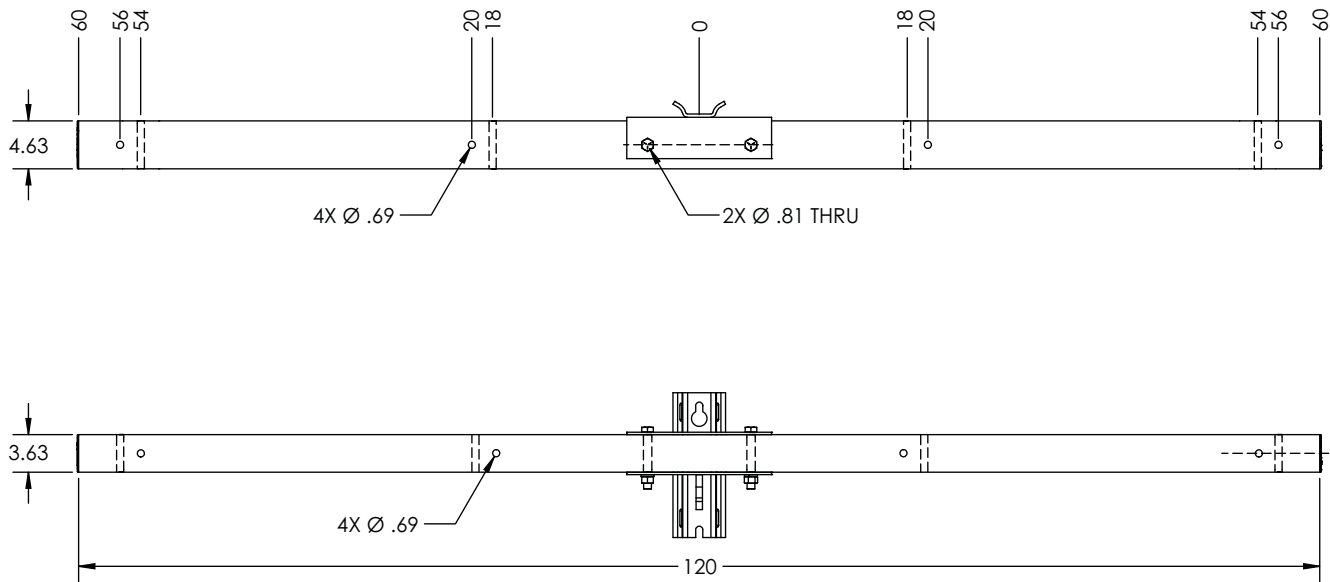
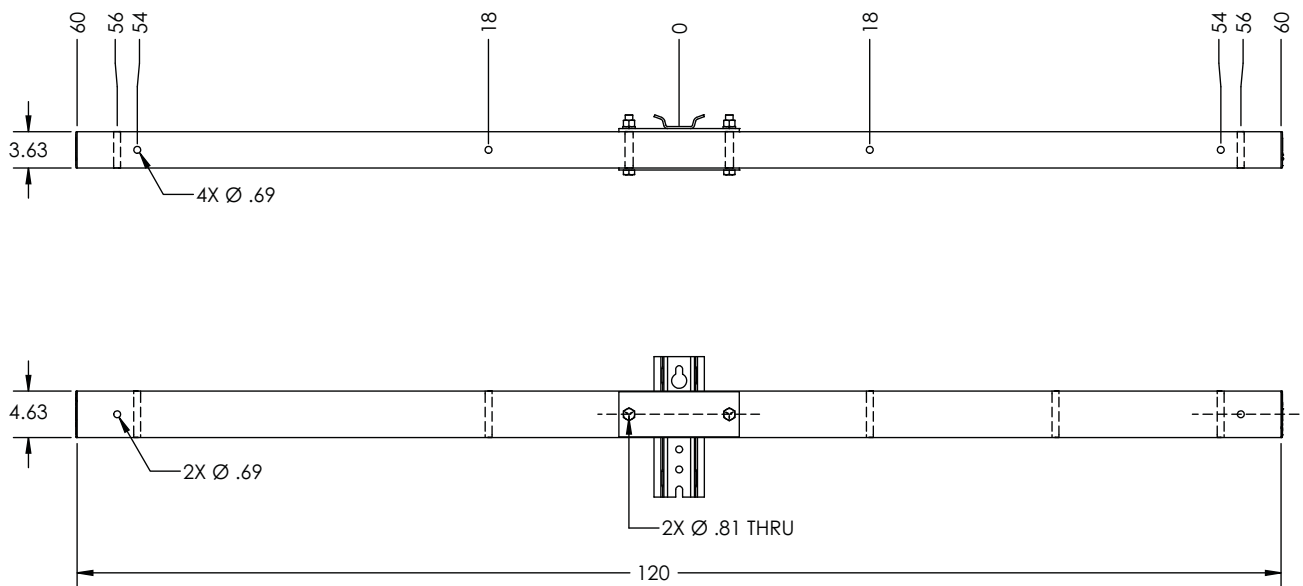

Figure CO 700-5: 10' Tangent Composite Crossarm Pre-Drilled Holes (SAP 10060794)



CO 700

Span Lengths, Minimum Conductor Spacing, Composite and Wood Crossarm
Pre-Drilled Holes

Approved by:

ajf

Sheet 4 of 12

What's Changed?

Effective Date:

DOH

01-25-2019

Figure CO 700-6: 12' Dead-End Composite Crossarm Hole Drilling (SAP 10060798)

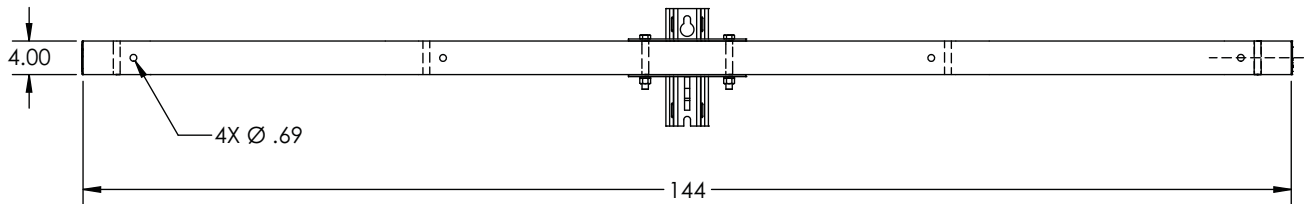
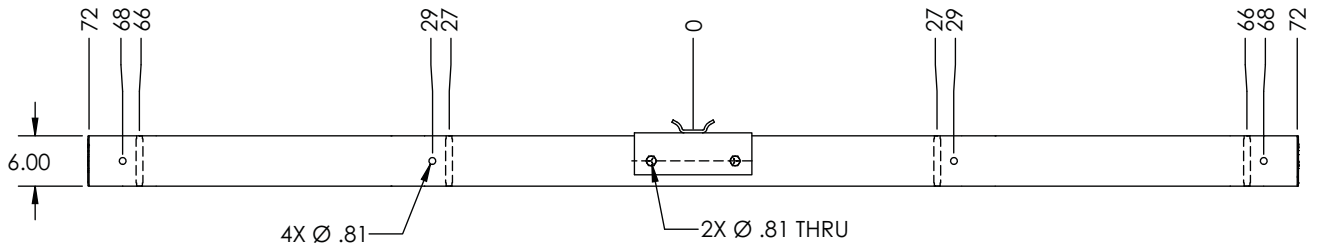
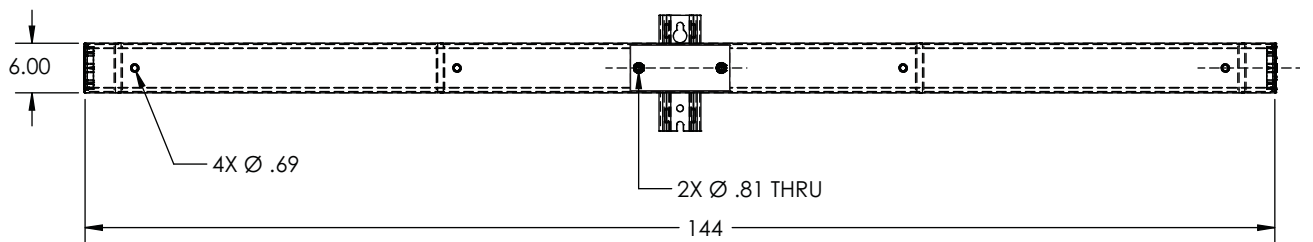
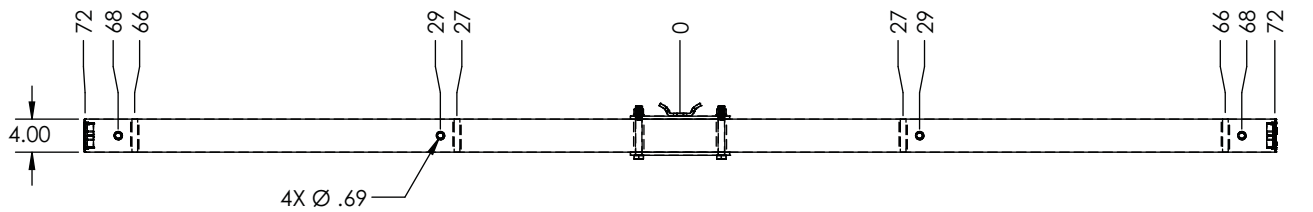

Figure CO 700-7: 12' Tangent Composite Crossarm Hole Drilling (SAP 10060795)



Approved by: <i>ajf</i>	Span Lengths, Minimum Conductor Spacing, Composite and Wood Crossarm Pre-Drilled Holes	CO 700	
Effective Date: 01-25-2019		What's Changed?	Sheet 5 of 12
			DOH

Figure CO 700-8: 10' Tangent Alley Composite Crossarm Pre-Drilled Holes (SAP 10211423)

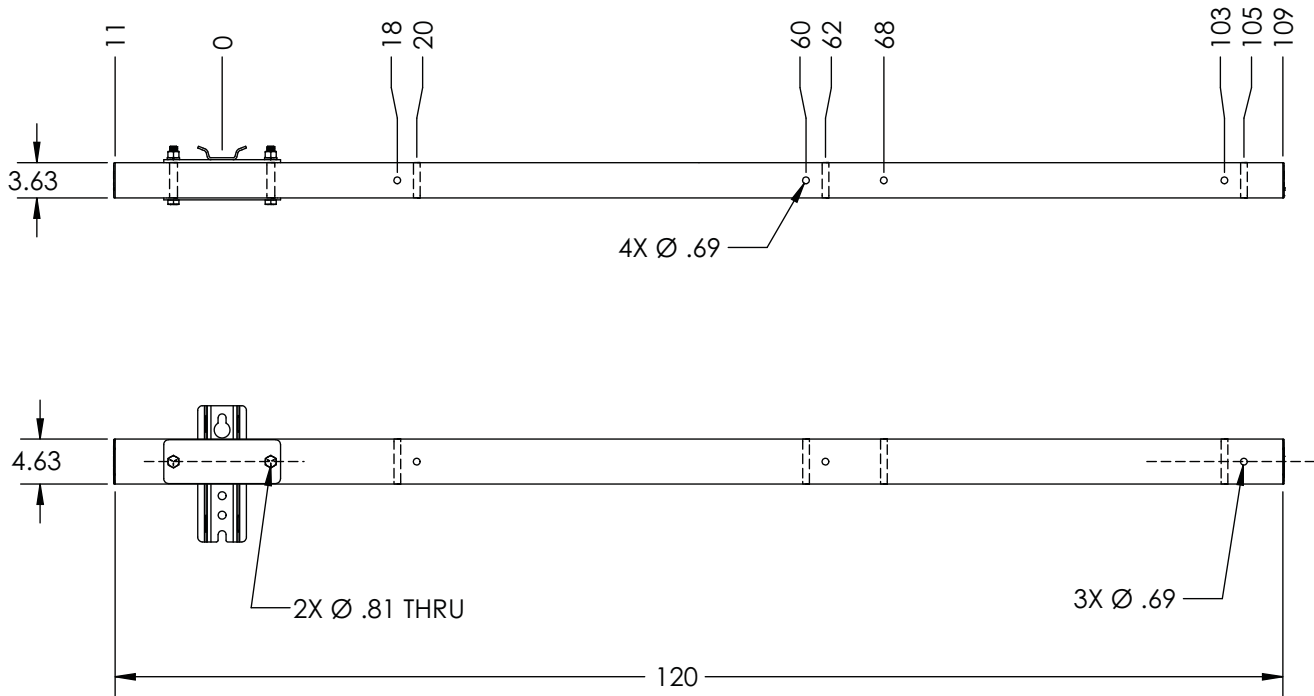

Figure CO 700-9: 12' Tangent Alley Composite Crossarm Pre-Drilled Holes (SAP 10211424)

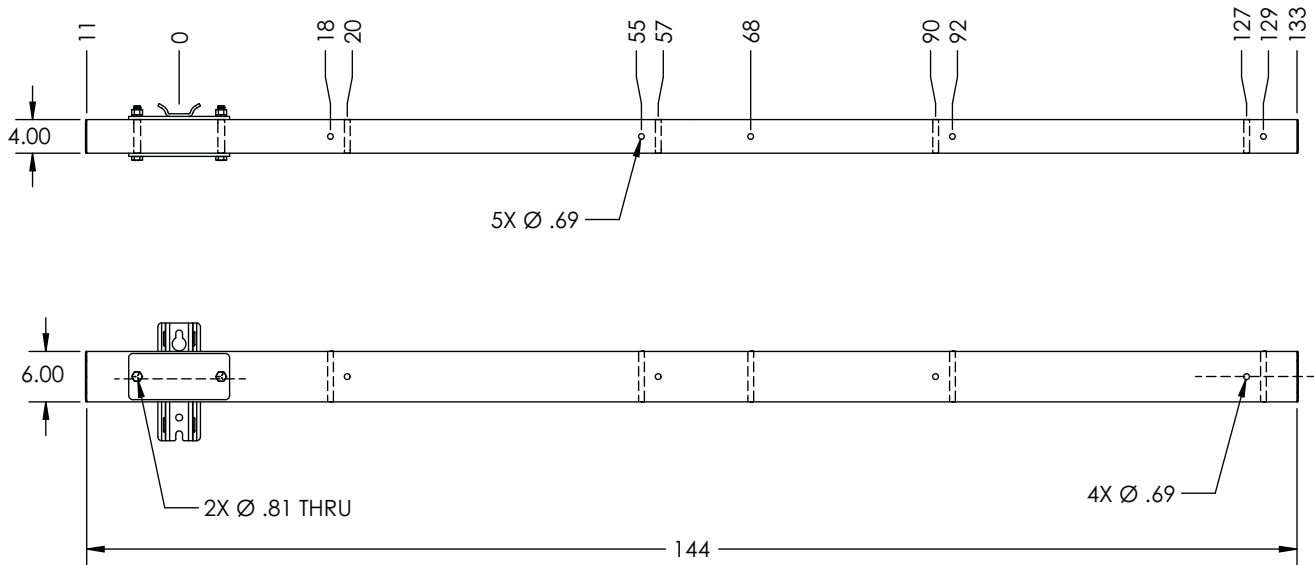

Figure CO 700-10: 20' Dead-End Composite Crossarm Pre-Drilled Holes (SAP 10208513)

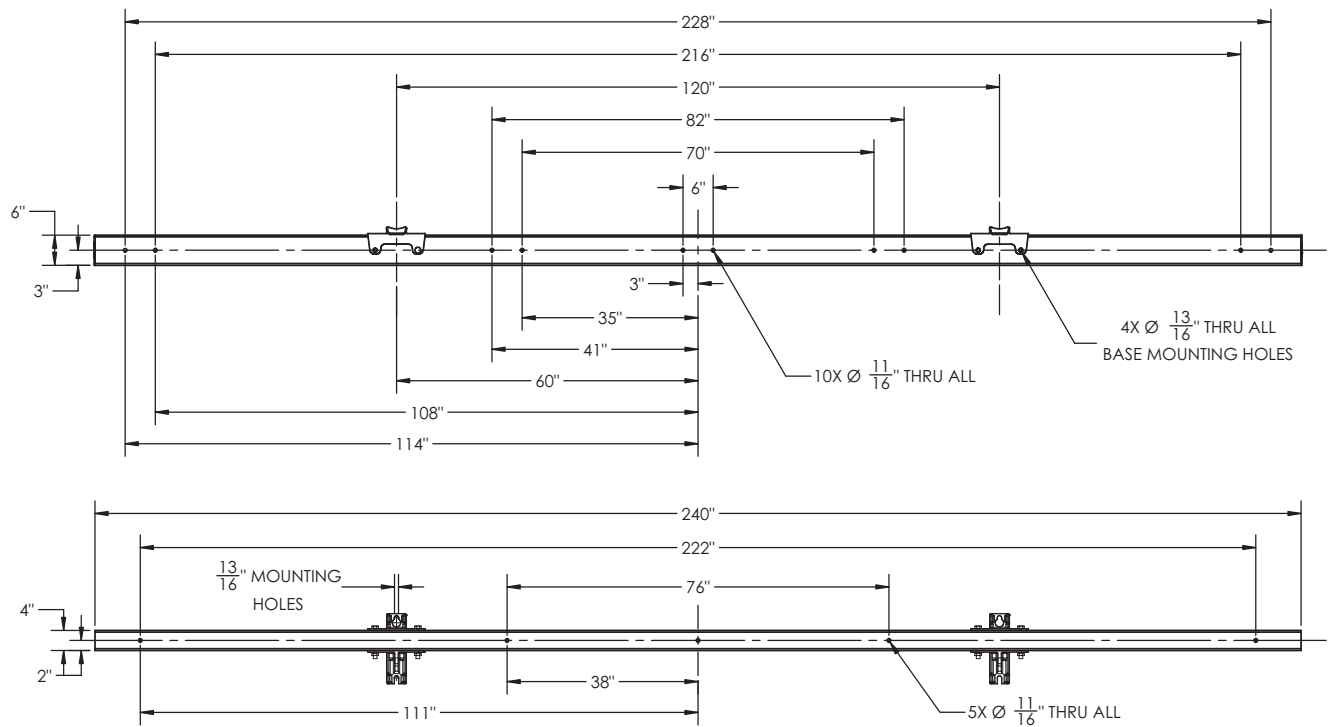
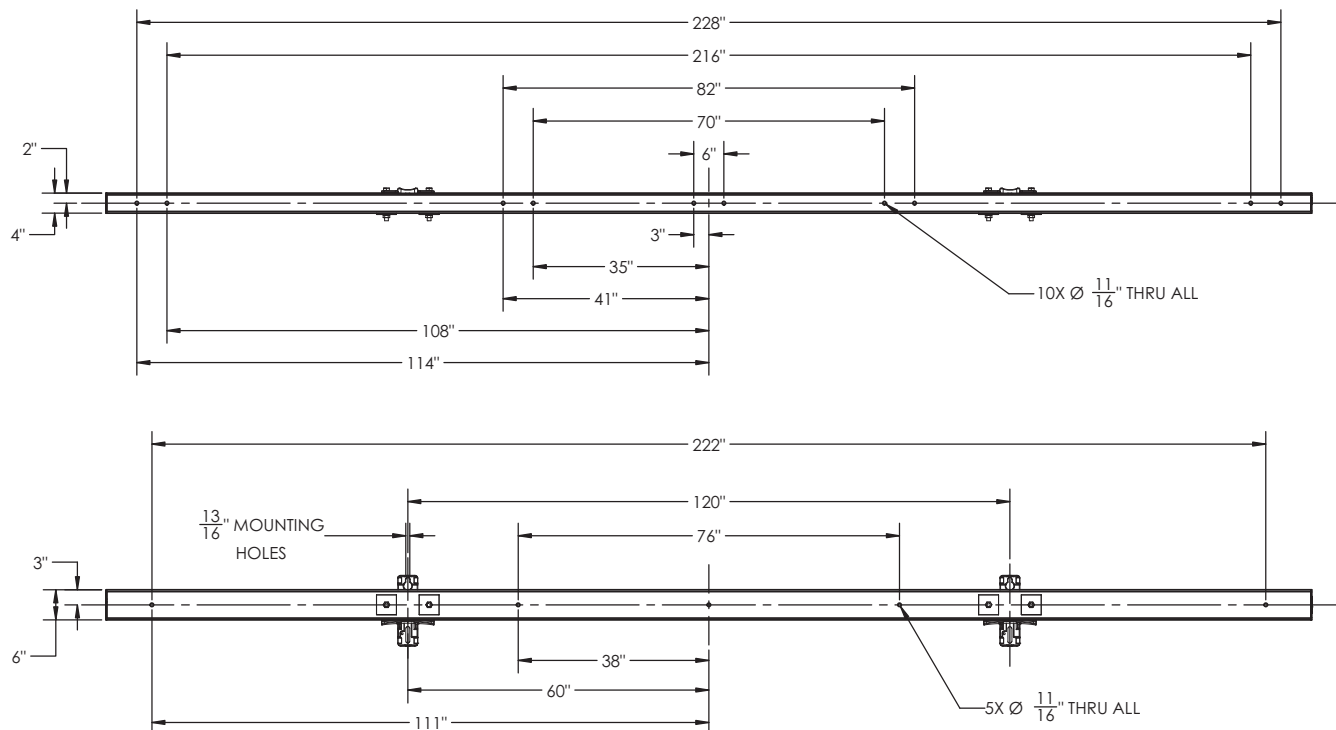

Figure CO 700-11: 20' Tangent Composite Crossarm Pre-Drilled Holes (SAP 10208033)



Approved by:

ajf

**Span Lengths, Minimum Conductor Spacing, Composite and Wood Crossarm
Pre-Drilled Holes**

Effective Date:

01-25-2019

What's Changed?

CO 700

Sheet 7 of 12

DOH

Scope CO 700.3 8' and 10' Composite Crossarm Mounting Bracket Details

Figure CO 700-12: PUPI Dead-End Mounting Bracket Detail

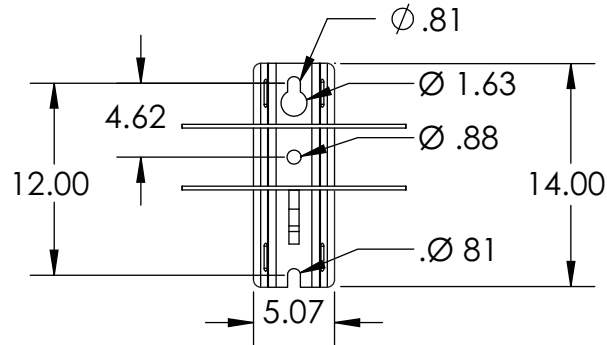
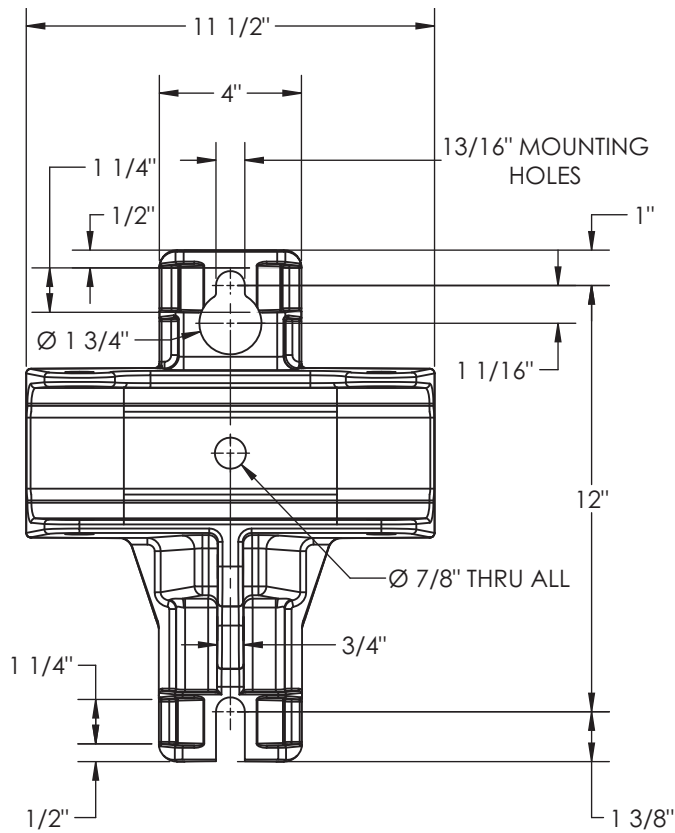

Figure CO 700-13: MacLean Dead-End Mounting Bracket Detail



CO 700

Sheet 8 of 12

DOH

Span Lengths, Minimum Conductor Spacing, Composite and Wood Crossarm
Pre-Drilled Holes

What's Changed? Updated for clarity.

Approved by:

a/j

Effective Date:

01-25-2019

Figure CO 700-14: PUPI Tangent Mounting Bracket Detail

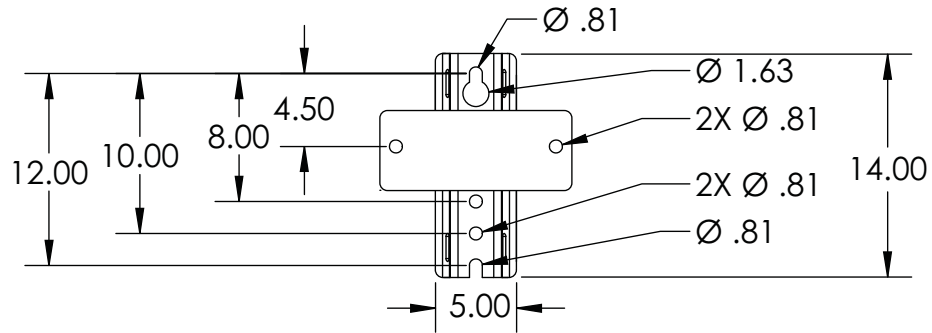
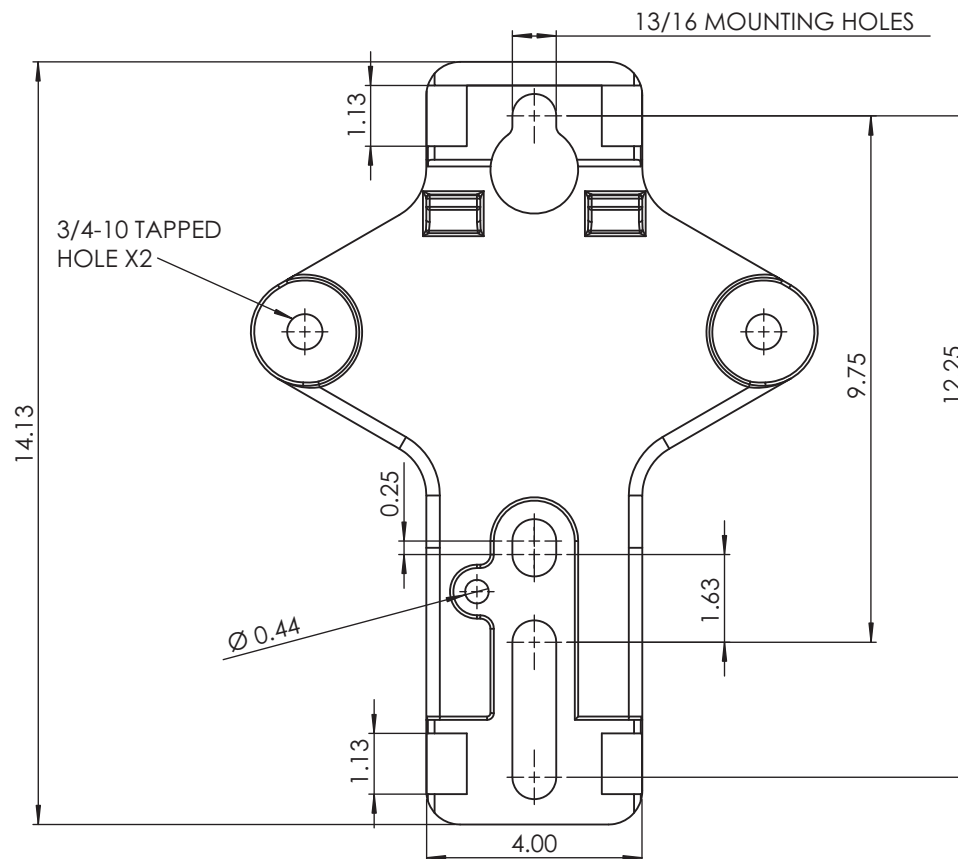

Figure CO 700-15: MacLean Tangent Mounting Bracket Detail



Approved by:

ajf

**Span Lengths, Minimum Conductor Spacing, Composite and Wood Crossarm
Pre-Drilled Holes**

Effective Date:

01-25-2019

What's Changed? Updated for clarity.

CO 700

Sheet 9 of 12

DOH

Scope CO 700.4 12' and 20' Composite Crossarm Mounting Bracket Details

Figure CO 700-16: PUPI Dead-End Mounting Bracket Detail

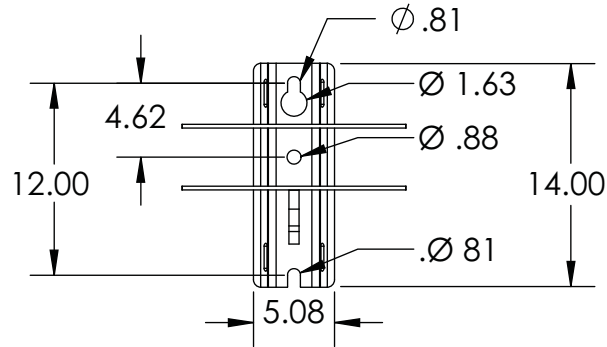
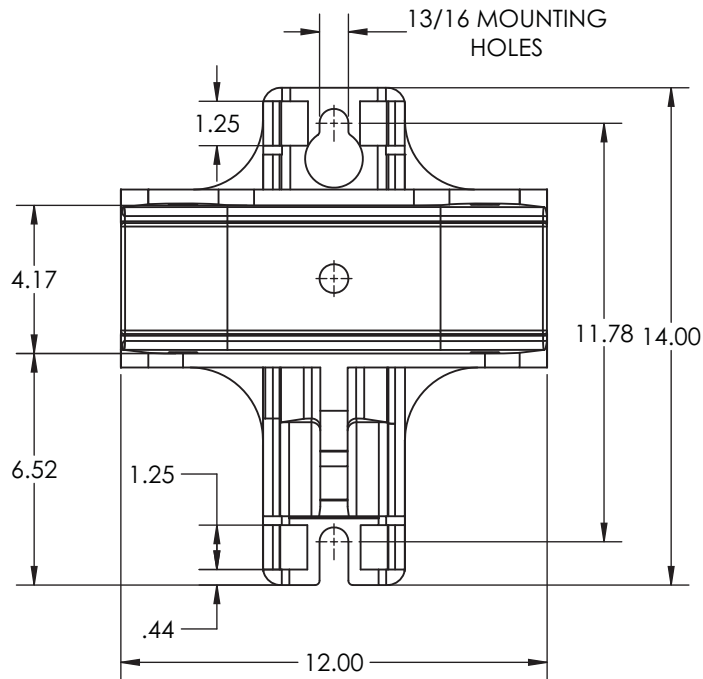

Figure CO 700-17: MacLean Dead-End Mounting Bracket Detail



CO 700

Span Lengths, Minimum Conductor Spacing, Composite and Wood Crossarm
 Pre-Drilled Holes

Approved by:

ajf

Sheet 10 of 12

What's Changed? Updated for clarity.

Effective Date:

01-25-2019

DOH

Figure CO 700-18: PUPI Tangent Mounting Bracket Detail

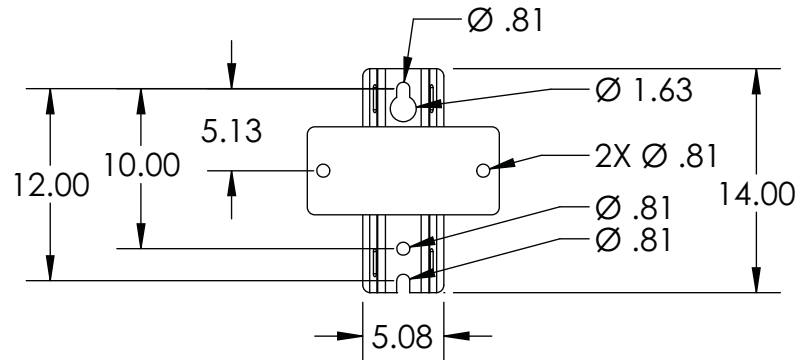
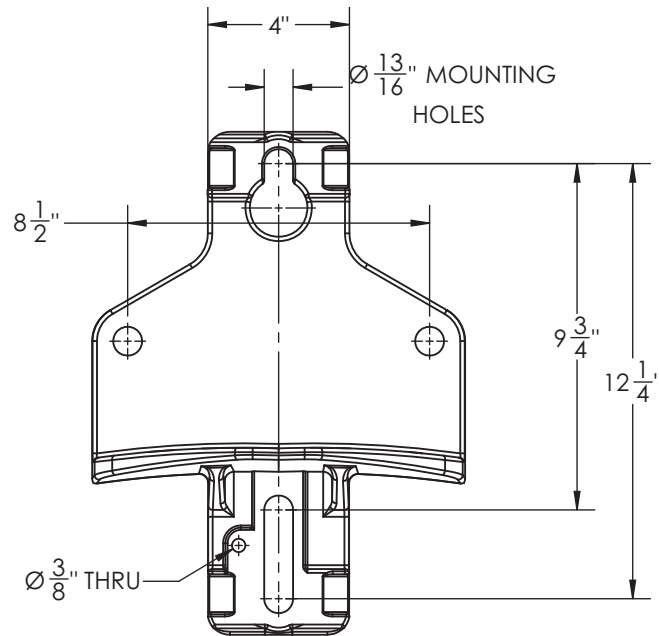

Figure CO 700-19: MacLean Tangent Mounting Bracket Detail



Approved by:

ajf

**Span Lengths, Minimum Conductor Spacing, Composite and Wood Crossarm
Pre-Drilled Holes**

Effective Date:

01-25-2019

What's Changed? Updated for clarity.

CO 700

Sheet 11 of 12

DOH

Scope CO 700.5 Wood Crossarm Pre-Drilled Holes

Figure CO 700-20: 5' Wood Crossarm Pre-Drilled Holes (SAP 10060238)

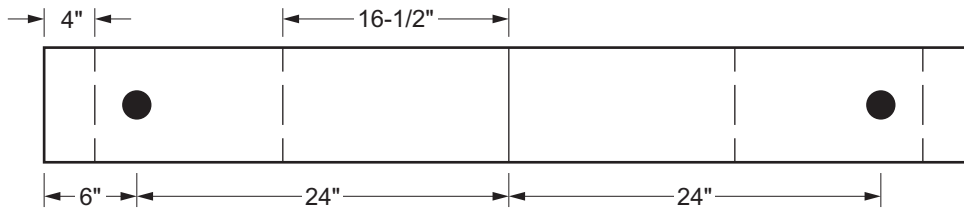

Figure CO 700-21: 8' Wood Crossarm Pre-Drilled Holes (SAP 10060237)

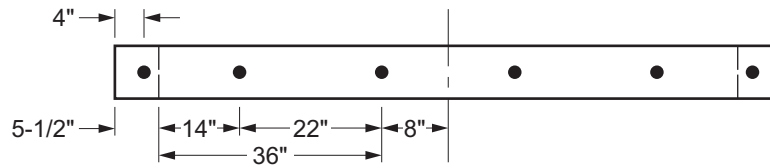

Figure CO 700-22: 10' Wood Crossarm Pre-Drilled Holes (SAP 10060240)

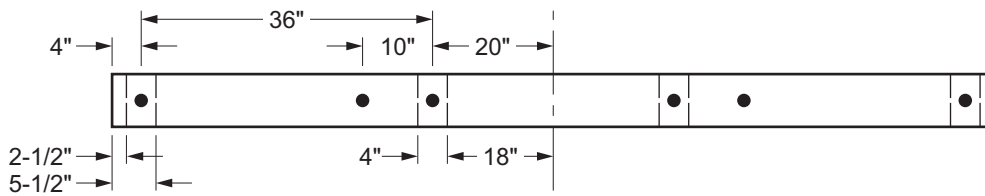
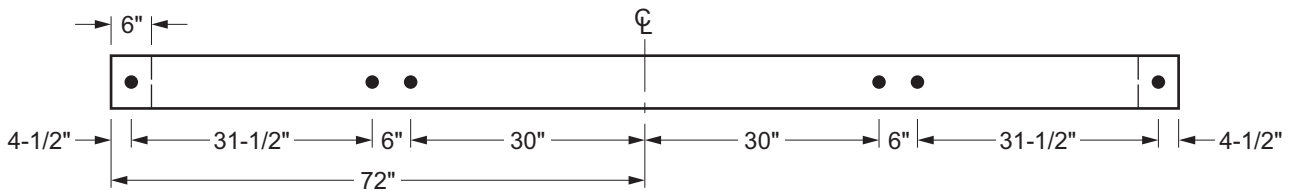

Figure CO 700-23: 12' Wood Crossarm Pre-Drilled Holes (SAP 10060209)



DOH-DC: Distribution Construction

TABLE OF CONTENTS

<u>STANDARD</u>	<u>TITLE</u>
DC 100	Climbing/Working Space — General
DC 100.1	General Climbing and Working Space Requirements for Crossarm Construction
DC 100.2	Climbing and Working Space without Crossarms
DC 100.3	Climbing Space and Horizontal Conductor Spacing
DC 110	Climbing/Working Space 3-Wire Corner
DC 110.1	Climbing/Working Space 3-Wire Corner
DC 120	Climbing/Working Space 4-Wire Corner
DC 120.1	Climbing/Working Space 4-Wire Corner
DC 200	Typical Poleheads/Clearances
DC 200.1	Polehead, Conductor Clearances, and Grade Clearances for Various Sizes of Poles
DC 220	Typical Poleheads/Clearances — Wire Line Communication
DC 220.1	Typical Poleheads/Clearances — Wire Line Communication
DC 222	Non-SCE Antennas
DC 222.1	Non-SCE Antennas
DC 230	Centerline Dead-Ending 3-Wire Corner
DC 230.1	Centerline Dead-Ending 3-Wire Corner
DC 240	Blackwell Corner 12/16 kV 3/4 Wire Alternate Method (for Existing Installations)
DC 240.1	Blackwell Corner 12/16 kV 3/4 Wire Alternate Method (for Existing Installations)
DC 320	Triplex/Straight Line Construction
DC 320.1	Typical Straight Line Construction for Triplex Conductors
DC 321	Triplex/Dead-ends/Corners
DC 321.1	Typical Secondary Construction for Triplex/Dead-Ends/Corners
DC 322	Triplex/Angle Construction
DC 322.1	Angle Construction
DC 323	Triplex/Service Terminations
DC 323.1	Triplex/Service Terminations
DC 324	Triplex/Splicing Method
DC 324.1	Triplex/Splicing Method
DC 325	Secondary Aluminum/Dead-End/Splicing Material
DC 325.1	Secondary Aluminum Supply Dead-End Grips and Splices
DC 400	Distribution Circuits 0–750 V Secondaries
DC 400.1	Distribution Circuits 0–750 V Secondaries
DC 410	0–7,500 V Straight-Line Pole — Typical
DC 410.1	Typical Pole Configurations for 0–7,500 V Straight-Line Construction

Approved by: <i>ajf</i>	Distribution Construction Table of Contents	DC
Effective Date: 01-25-2019		Sheet 1 of 4
		DOH

STANDARD	TITLE
DC 415	0–7500 V Angle Pole — Typical
DC 415.1	0–7500 V Angle Pole — Typical
DC 415	0–7500 V Angle Pole — Typical
DC 415.1	0–7500 V Angle Pole — Typical
DC 500	Rural, Standard, and Long Span Construction for 3-Wire 12 kV, 16 kV, and 33 kV Horizontal Configuration
DC 500.1	Typical Pole Configurations for Straight Line Rural, Standard, and Long Span Horizontal Construction 12 kV, 16 kV, and 33 kV 3-Wire Circuit
DC 510	12/16 kV 4-Wire Straight Line — Typical
DC 510.1	Typical Pole Configuration for Straight Line Horizontal Construction — 12/16 kV — 4-Wire Circuit
DC 520	Distribution Circuit — Heavy-Loading Areas above 5,000 Feet Elevation
DC 520.1	Construction Requirements for Heavy-Loading Areas above 5,000 Feet Elevation — 12/16/33 kV Construction General Requirements
DC 520.2	Territory Map of Heavy-Loading Areas above 5,000 Feet Elevation
DC 520.3	Typical Construction Practices for 12/16 kV — 3-Wire and 4-Wire — Heavy Loading above 5,000 Feet Elevation
DC 520.4	Typical 12/16/33 kV Horizontal 3-Wire Straight Line Configuration — Heavy Loading above 5,000 Feet Elevation
DC 530	All Distribution Voltages 3/4-Wire Suspension Construction
DC 530.1	Distribution Suspension Construction — High-Wind Areas Only
DC 535	Wildlife-Safe Power Line Construction
DC 535.1	Wildlife-Safe Power Line Construction
DC 538	Aerial Line Marker
DC 538.1	Aerial Line Marker
DC 540	12/16/25/33 kV 3/4-Wire Vertical Construction
DC 540.1	Typical Construction for 12/16/25/33 kV 3/4-Wire Vertical Construction
DC 550	All Distribution Voltages, 3/4-Wire Alley Arm Construction
DC 550.1	All Distribution Voltages, 3/4-Wire Alley Arm Construction
DC 560	12/16/25/33 kV 3/4-Wire Barre Corner Construction
DC 560.1	12/16/25/33 kV 3/4-Wire Barre Corner Construction
DC 570	4/12/16 kV 3/4-Wire Dead-End Construction
DC 570.1	4/12/16 kV 3/4-Wire Dead-End Construction
DC 575	12/16/25/33 kV 3/4-Wire Angle Pole Construction
DC 575.1	12/16/25/33 kV 3- or 4-Wire Angle Pole Construction
DC 580	12/16/33 kV 3- or 4-Wire Double Dead-End Construction for Wood and Composite Arms
DC 580.1	12/16/33 kV 3- or 4-Wire Double Dead-End Construction for Wood and Composite Arms

STANDARD	TITLE
DC 585	Determination of Deviation Angle
DC 585.1	Determination of Deviation Angle
DC 585.2	Determination of Line Angle and Deviation Angle for Use in Switch and Line Pole Angle Determination
DC 586	3- and 4-Wire Transposition Construction
DC 586.1	3- and 4-Wire Transposition Construction
DC 590	Mid-Span Tap Construction
DC 590.1	Mid-Span Tap Construction
DC 605	Distribution Circuits — Bulletin 322 Requirements
DC 605.1	2.4 kV through 33 kV Special Overhead Construction Line Requirements for Areas Affected by Dispatchers Bulletin 322 (High Fire-Hazard Areas)
DC 605.2	Typical Distribution Circuits — Bulletin 322 Requirement
DC 610	4/12/16 kV OH Branch Line Fusing
DC 610.1	Typical Branch Fuse Construction for 1Ø Double Dead-End Straight Line Pole
DC 610.2	Typical Branch Fuse Construction for 3Ø Double Dead-End Straight Line Pole Construction
DC 610.3	Typical Branch Fuse Construction for 3Ø 3/4 Wire Double Dead-End Straight Line Pole Construction
DC 610.4	Typical 12/16 kV Branch Fuse Construction for 3Ø Centerline Double Dead-End Straight Line Pole Construction — Top of Pole Only — 3-Wire Construction
DC 610.5	Typical Branch Fuse Construction for 1Ø/3Ø Break-Off Pole
DC 610.6	Typical Branch Fuse Construction for 1Ø/3Ø Break-Off Pole — Top of Pole Only
DC 612	Spring Washer Hardware Connection Details
DC 612	Spring Washer Hardware Connection Details
DC 615	Back Brace Installation Criteria
DC 615	Back Brace Installation Criteria
DC 620	Suggested Location of Ferroresonance Safety Instruction Signs
DC 620.1	Suggested Location of Ferroresonance Safety Instruction Signs
DC 630	H-Frame 3- and 4-Wire Construction (All Distribution Voltages)
DC 630.1	H-Frame, Single Circuit, Single-Arm, Suspension, 3-Wire, 20-foot (6" x 6") Timbers
DC 630.2	H-Frame, Single Circuit, Single-Arm, Suspension, 3-Wire, 16-foot (3-1/2" x 5-1/2") Timbers
DC 630.3	H-Frame, Single Circuit, Single-Arm, Suspension, 4-Wire, 20-foot (6" x 6") Timbers
DC 630.4	H-Frame, Single Circuit, Single-Arm, Suspension, 4-Wire, 16-foot (3-1/2" x 3-1/2") Timbers
DC 630.5	H-Frame, Single Circuit, Double-Arm, Suspension or Dead-End, 3-Wire, 20-foot (6" x 6") Timbers
DC 630.6	H-Frame, Single Circuit, Double-Arm, Suspension or Dead-End, 3-Wire, 16-foot (3-1/2" x 5-1/2") Timbers
DC 630.7	H-Frame, Single Circuit, Double-Arm, Suspension or Dead-End, 4-Wire, 20-foot (6" x 6") Timbers
DC 630.8	H-Frame, Single Circuit, Double-Arm, Suspension or Dead-End, 4-Wire, 16-foot (3-1/2" x 5-1/2") Timbers

Approved by: <i>ajf</i>	Distribution Construction Table of Contents	DC
Effective Date: 01-25-2019		Sheet 3 of 4
		DOH

STANDARD	TITLE
DC 635	Smith Corner 3- and 4-Wire Construction (All Distribution Voltages)
DC 635.1	Double Circuit, Pin-Type Jumper Support Insulators, Smith Corner, 3-Wire
DC 635.2	Double Circuit, Suspension Jumper Support Insulators, Smith Corner, 3-Wire
DC 635.3	Double Circuit, Pin-Type Jumper Support Insulators, Smith Corner, 4-Wire
DC 635.4	Double Circuit, Suspension Jumper Support Insulators, Smith Corner, 4-Wire
DC 640	Overhead Platform Rack Structures
DC 640.1	Overhead Platform Rack Structures (2-Pole and 3-Pole Design)
DC 640.2	Equipment Anchorage for Overhead Platform Racks

DC 222 Non-SCE Antennas

Scope DC 222.1 Non-SCE Antennas

1.0 General Information

- 1.1 This standard applies to non-SCE antennas (antennas) affixed to distribution poles supporting SCE lines, streetlights, secondary risers, and guys (facilities).
- 1.2 This is a construction standard and is not intended to endorse or assure the installation of antennas on SCE poles.
- 1.3 This standard, including the Figures and Notes, supplement the minimum requirements established in the California Public Utilities Commissions' General Order (G.O.) 95, including Rule 94 and all other applicable rules. If an SCE standard and a G.O. 95 rule conflict, the more stringent of the two shall be applied.
- 1.4 For policies related to the construction and maintenance of antennas on distribution poles, refer to Distribution Design Standard, DDS-10, Section 5.7 G.

2.0 Support Elements

- 2.1 Cables, messengers, ground and bond wires, and incidental wiring associated with antennas shall meet the requirements for Class C circuits as specified in G.O. 95, except as modified by this standard.
- 2.2 Incidental wiring and miscellaneous equipment associated with antennas shall be installed in a workman like fashion so as to not interfere with workers ascending or descending the pole, or nearby communication and/or SCE facilities.
- 2.3 Hardware (for example, brackets, crossarms, braces) associated with antennas affixed above SCE facilities shall (at a minimum) meet the material strength requirements and safety factors for Grade "A" construction as specified in Section IV of G.O. 95.
 - A. Hardware associated with pole mounted antennas shall be reviewed and approved by SCE prior to construction.
 - 1. Crossarms supporting antennas above 2.4–33 kV lines are prohibited.
 - 2. Crossarms supporting antennas above 120–480 V lines and guys shall extend no more than 5 feet horizontally from the centerline of the support pole.
 - The maximum allowable crossarm length is 10 feet.
- 2.4 Hardware associated with antennas affixed below distribution facilities shall (at a minimum) meet the material strength requirements and safety factors for Grade "C" construction as specified in Section IV of G.O. 95.

Approved by: <i>ajf</i>	Non-SCE Antennas	DC 222
Effective Date: 01-25-2019	What's Changed?	Sheet 1 of 10 DOH

- 2.5 Pole-top extensions meeting the requirements of **PO 150** may be utilized to support antennas above 120–480 V lines and atop guy poles.
 - A. Where a pole-top extension is intended for use, a soil strength calculation for the support pole must be submitted with other required pole load calculations.
- 2.6 Pull boxes, handholes, and other subsurface enclosures shall be situated so as to not interfere with down guys, guy anchors, vehicle and pedestrian traffic.
- 2.7 Pedestals and above ground equipment shall be situated so as to not interfere with down guys, guy anchors, vehicle and pedestrian traffic.

3.0 Clearances

- 3.1 Figures **DC 222–1**, **DC 222–2**, **DC 222–3**, and **DC 222–4** specify the required minimum vertical, horizontal and/or radial clearances. Refer to the Accident Prevention Manual (APM) Rule 114 for working clearances.
- 3.2 Antennas affixed above or below lines or guys, shall maintain clearances from unattached electric and communication lines in accordance with G.O. 95, Rule 38, Table 2, Case 3, Columns A–K.
 - Pole-top antennas placed on distribution poles up to 33 kV lines are addressed by this standard.
 - Pole-top antennas above 33 kV transmission lines are prohibited.
- 3.3 Antennas affixed below lines shall not be installed directly below polemounted streetlight fixtures nor interfere with the intended illumination pattern.
- 3.4 Approved antenna equipment (for example, light wave converters, amplifiers, grounding devices, batteries) affixed to the support pole shall meet the follow requirements:
 - A. Vertical clearance above the ground line (lowest part): 8 feet (MIN)
 - B. Vertical clearance above the ground line (upper most part): 16 feet (MAX)
 - C. Dimensions of equipment (separate or combined): 96 × 30 × 18 inches (MAX)
 - D. Weight of equipment: No maximum is prescribed, however, vertical loading must be calculated and the support pole appropriately sized.
 - E. Equipment measuring 24 × 24 × 12 inches or larger, (separately or combined) shall be installed with at least 6 inches of horizontal separation measured from the surface of the pole to the nearest part.

DC 222	Non-SCE Antennas	Approved by: 
Sheet 2 of 10	What's Changed? Section 3.2 has been updated for clarity.	Effective Date:
DOH		01-25-2019

4.0 Marking

- 4.1 Antenna owner/operators shall provide, and update as necessary, accurate information regarding compliance with the Federal Communications Commission’s Maximum Permissible Exposure (MPE) limits as set forth in Title 47 of the Code of Federal Regulations (CFR) for each antenna site.
- 4.2 Antenna owner/operators shall install signs or decals made of weather, corrosion, and Ultraviolet (UV) resistant materials. At a minimum, each sign or decal shall indicate the antenna owner/operator name; emergency 24-hour contact number; unique identifier for the antenna site; and SCE equipment catalog number (for pole-top installations).
- 4.3 Affix required signs/decals at two locations on the support structure so they are clearly visible:
 - A. 3–4 feet below the antenna (measured from the top of the sign).
 - B. 8–10 feet above the ground (measured from the bottom of the sign).
- 4.4 When the modifying an existing antenna site that requires the replacement or modification of existing markings the antenna owner/operator shall:
 - A. Notify SCE and all other pole occupants in writing and place new signs/decals that include the information listed in 4.2 (above) and as listed below:
 - 1. The applicable FCC exposure category (General Population/Uncontrolled or Occupational/Controlled); and
 - 2. FCC’s recommended minimum approach distance.

5.0 Climbing Space

- 5.1 Where antennas are installed above lines or guys, climbing space shall be established and maintained in accordance with G.O. 95, Rule 54.7-A from the ground line to the bottom of the antenna hardware.
- 5.2 Where antennas are installed below lines or guys, climbing space shall be established and maintained in accordance with G.O. 95, Rule 84.7-A from the ground line to within 6 feet of the nearest line or guy.
- 5.3 Directional antennas shall be installed and oriented in a manner that limits RF energy within the climbing space.

Approved by: <i>ajf</i>	Non-SCE Antennas	DC 222
Effective Date: 01-25-2019	What’s Changed?	Sheet 3 of 10 DOH

6.0 Cable Risers and Grounds

- 6.1 Where antennas are installed above lines and guys atop wood or other nonmetallic poles, associated cable risers and vertical grounds shall be:
 - A. Adequately supported;
 - B. Encased in Schedule 40 PVC conduit;
 - C. Installed outside the climbing space; and
 - D. Meet the requirements of G.O. 95 Rule 54.6-D 1, 2, 3 and 5.
- 6.2 On wood poles, where one riser is present, one additional cable riser may be affixed directly to the pole, provided the climbing space is not impaired.
 - A. Appropriately sized galvanized pipe straps (with not less than three straps per each 10 feet length of conduit), and size 16D nails or equivalent lags shall be utilized.
- 6.3 On wood poles, where two or more risers are present, any additional risers shall be installed with unistrut or power-strut riser supports in accordance with DUG CR 110.2.
- 6.4 On Light Weight Steel poles where antenna risers are installed, unistrut or power-strut supports shall be utilized in accordance with DUG CR 141 (see Figure CR 141-2).
- 6.5 Cables emanating from a pole top antenna riser or transitioning from a vertical run that extends to an adjacent pole or building shall be:
 - A. Bonded to the support pole's existing communication cables and messengers;
 - B. Effectively grounded in accordance with G.O. 95 Rule 83.4; and
 - C. Where a guard arm is present, the bottom of the riser shall extend at least one foot below the guard arm.
- 6.6 Ground wires, connectors and associated grounding equipment installed on nonmetallic poles shall be installed outside the climbing space.
 - A. Ground wires shall be covered with Schedule 40 PVC conduit or its equivalent wood or PVC molding.

DC 222	Non-SCE Antennas	Approved by: <i>ajf</i>
Sheet 4 of 10	What's Changed?	Effective Date:
DOH		01-25-2019

7.0 Stepping

7.1 On wood see G.O. 95, Rule 91.3A.

- A. For wood poles where steps are required and all metallic or composite poles, the first pole step shall be installed not less than 9 feet above the ground line or any easily climbable foreign structure from which one could reach or step, with a maximum vertical separation of 3 feet on the same side of the pole.

8.0 Cable/Messenger Mounted

8.1 Cable/messenger mounted antennas shall be installed with at least:

- A. Six (6) feet of horizontal clearance measured from the nearest part of the antenna to the surface of the pole.
- B. Four (4) feet of vertical clearance below 120–480 V lines.
- C. 10 feet of vertical clearance below 2.4–33 kV lines (where no 120–480 V lines are present).
- D. Six (6) feet of horizontal clearance from self-supporting streetlights.

8.2 The maximum length of a cable/messenger mounted antennas is 3 feet

8.3 Cable/messenger mounted antennas shall not be installed below pole mounted streetlight fixtures nor interfere with the intended illumination pattern.

9.0 Emergency RF/Power Shut-Off Device

9.1 Antennas affixed to poles supporting lines, and/or guys, shall be installed with a device that disconnects all RF energy.

- A. This device may be affixed to the support pole, above ground communication equipment, or contained in a subsurface enclosure but must be located no more than 20 feet from the pole supporting the antenna and within line-of-sight.
 - For routine and emergency RF/Power Shut-Off protocols refer to DOM MO-1.
- B. Each device shall be permanently marked with a weather and UV resistant sign or decal that reads: SCE Emergency RF/Power Shut-Off Switch.
 - See [Figure DC 222–5](#).
- C. For non-metered cellular service equipment details, see [AP 800](#).

Approved by: 	Non-SCE Antennas	DC 222
Effective Date: 01-25-2019	What's Changed?	Sheet 5 of 10 DOH

Figure DC 222-1: Typical High Voltage Distribution Pole Non-SCE Antennas



Note(s):

1. Antenna markings shall be affixed so as to be clearly visible, at two locations on the support structure. 3–4 feet below the antenna (measured from the top of the sign), and 8–10 feet above the ground (measured from the bottom of the sign).
2. On wood poles, where two or more risers are present, any additional riser shall be installed with unistrut or power-strut supports in accordance with DUG CR 110.2.
3. Antennas atop HV distribution poles — no specified horizontal clearance between the pole and antenna.
4. The preferred location of RF/Power Shutoff Switch is the customer's pedestal, however, at SCE's discretion; the device may be affixed on the antenna pole (for non-metered cellular service equipment details, see AP 800).
5. Clearance dimensions shown are the required minimum vertical, horizontal, and/or radial clearances.

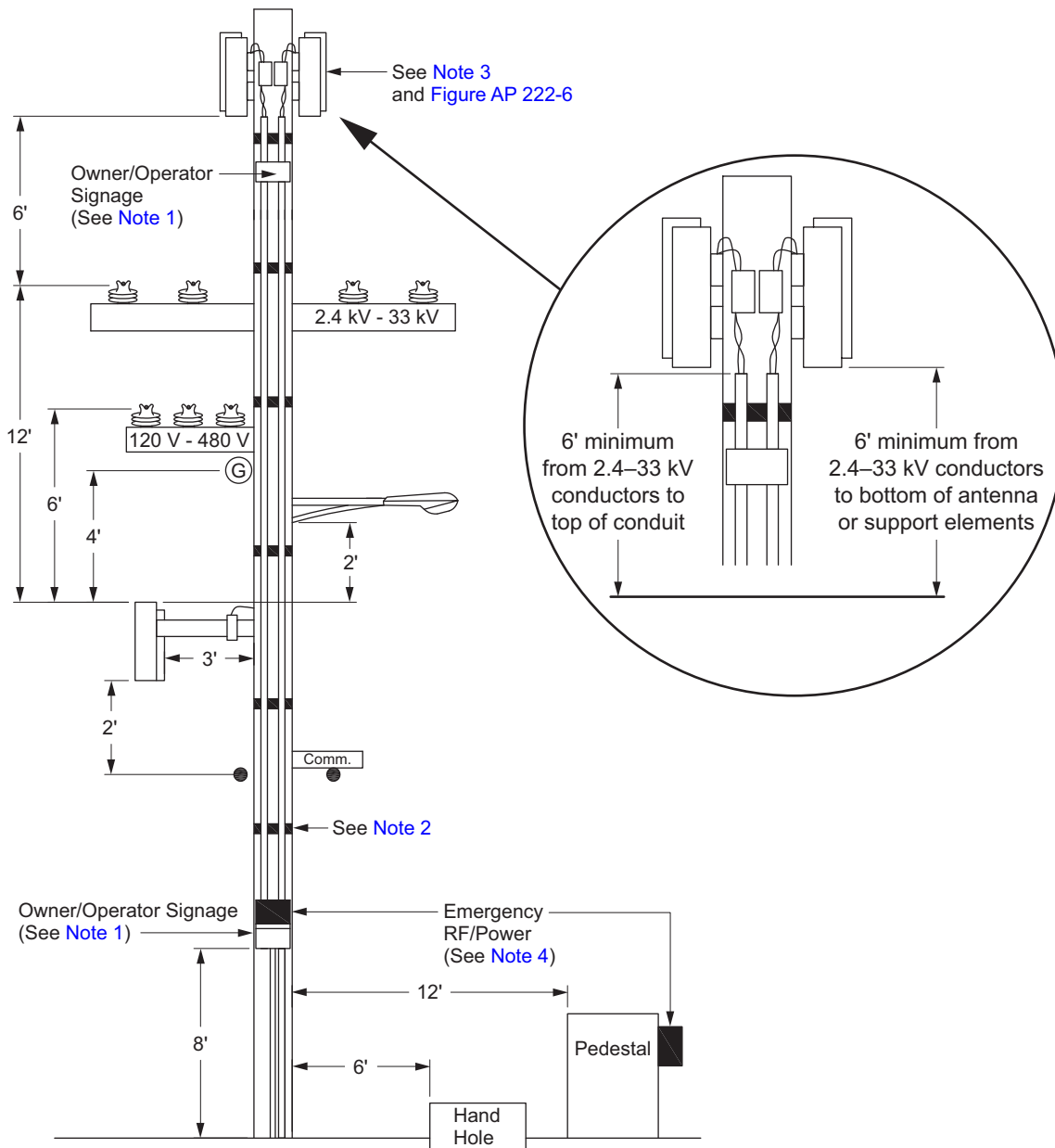
DC 222

Non-SCE Antennas

Approved by:

a/j

Sheet 6 of 10

What's Changed?

Effective Date:

DOH

01-25-2019

Figure DC 222–2: Typical Low Voltage Distribution Pole with Non-SCE Antenna

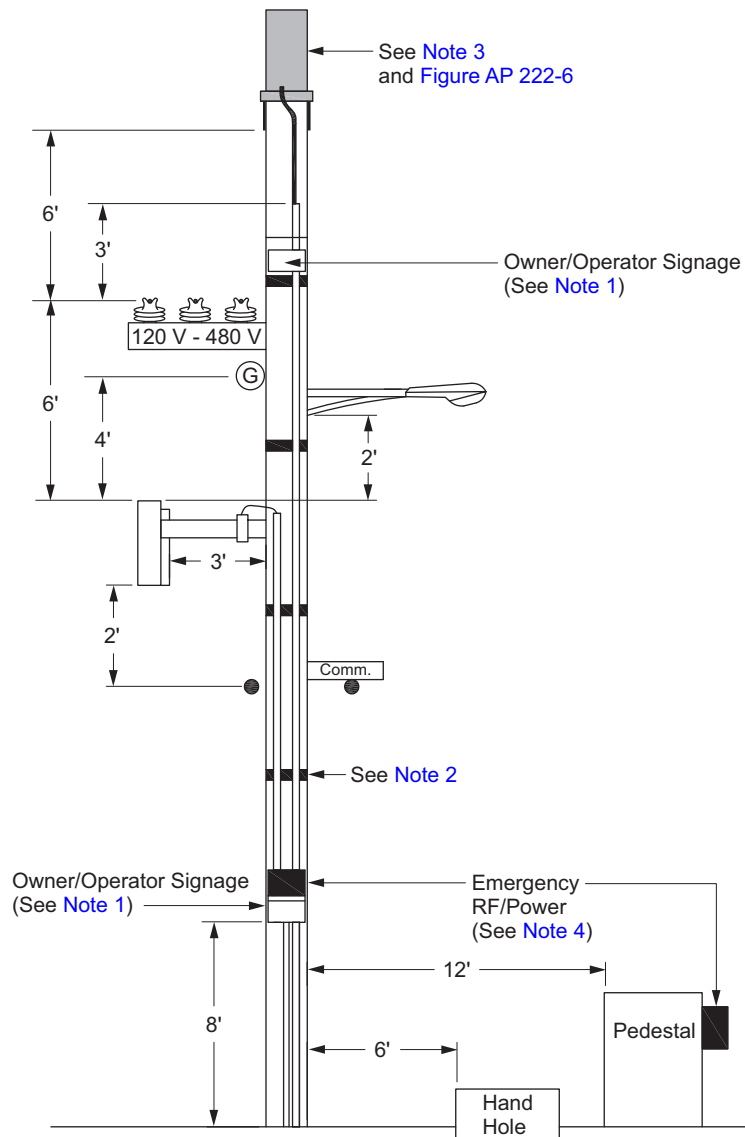

Note(s):

1. Antenna markings shall be affixed so as to be clearly visible, at two locations on the support structure. 3–4 feet below the antenna (measured from the top of the sign), and 8–10 feet above the ground (measured from the bottom of the sign).
2. On wood poles, where two or more risers are present, any additional riser shall be installed with unistrut or power-strut supports in accordance with DUG CR 110.2.
3. Antennas atop LV distribution poles — no specified horizontal clearance between the pole and antenna.
4. The preferred location of RF/Power Shutoff Switch is the customer's pedestal, however, at SCE's discretion; the device may be affixed on the antenna pole (for non-metered cellular service equipment details, see AP 800).
5. Clearance dimensions shown are the required minimum vertical, horizontal, and/or radial clearances.

Approved by:

ajf

Non-SCE Antennas

DC 222

Effective Date:

01-25-2019

What's Changed?

Sheet 7 of 10

DOH

Figure DC 222-3: Typical Guy Pole Non-SCE Antennas

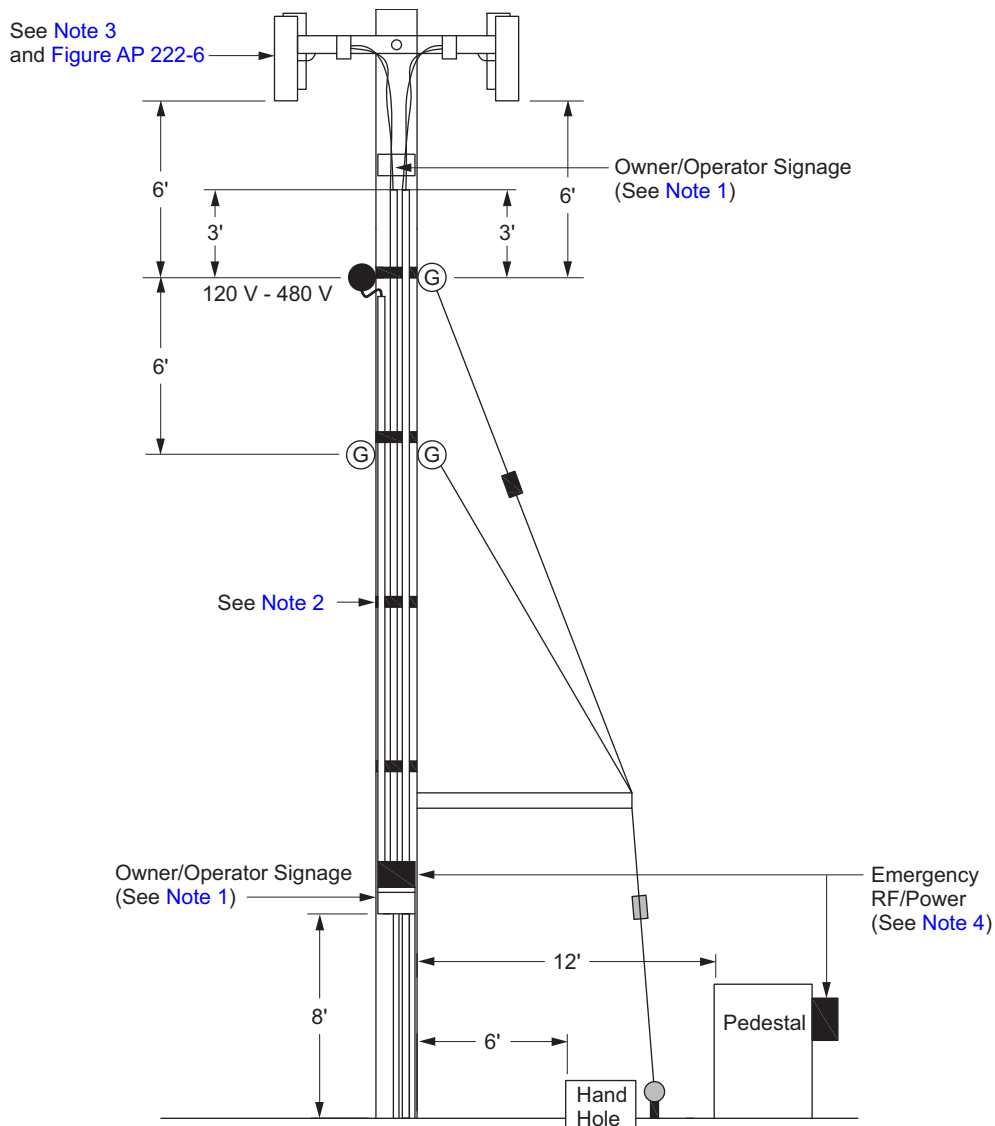

Note(s):

1. Antenna markings shall be affixed so as to be clearly visible, at two locations on the support structure. 3–4 feet below the antenna (measured from the top of the sign), and 8–10 feet above the ground (measured from the bottom of the sign).
2. On wood poles, where two or more risers are present, any additional riser shall be installed with unistrut or power-strut supports in accordance with DUG CR 110.2.
3. Antennas atop guy poles — no specified horizontal clearance between the pole and antenna.
4. The preferred location of RF/Power Shutoff Switch is the customer's pedestal, however, at SCE's discretion; the device may be affixed on the antenna pole (for non-metered cellular service equipment details, see AP 800).
5. Clearance dimensions shown are the required minimum vertical, horizontal, and/or radial clearances.
6. Antennas may only be affixed at the top under a pole license agreement.

DC 222

Non-SCE Antennas

Approved by:

a/j

Sheet 8 of 10

What's Changed? Figure DC 222-2 Note 6 has been updated for clarity.

Effective Date:

DOH

01-25-2019

Figure DC 222-4: HV Distribution Pole with Cable/Strand Mounted Omni Antenna

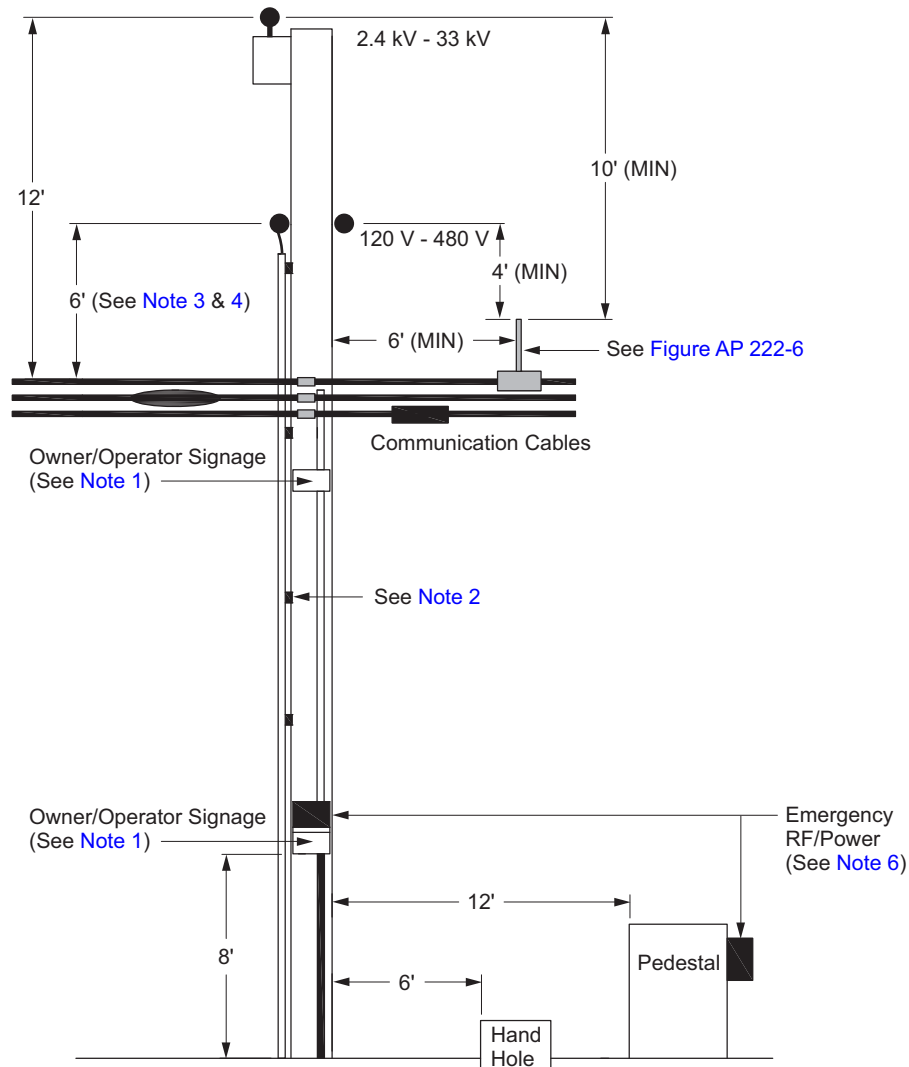

Note(s):

1. Antenna markings shall be affixed so as to be clearly visible, at two locations on the support structure. 3–4 feet below the antenna (measured from the top of the sign), and 8–10 feet above the ground (measured from the bottom of the sign).
2. On wood poles, where two or more risers are present, any additional riser shall be installed with unistrut or power-strut supports in accordance with DUG CR 110.2.
3. Unguarded communication cables below distribution lines (120–480 V) require 6 feet vertical clearance (measured from centerline of conductor to centerline of nearest communication cable).
4. Guarded communication cables below distribution lines (120–480 V) require 4 feet vertical clearance (measured from centerline of conductor to centerline of nearest communication cable).
5. Cable/strand mounted antennas: Maximum length — 3 feet.
6. The preferred location of RF/Power Shutoff Switch is the customer's pedestal, however, at SCE's discretion; the device may be affixed on the antenna pole (for non-metered cellular service equipment details, see AP 800).
7. Clearance dimensions shown are the required minimum vertical, horizontal, and/or radial clearances.

Approved by:

ajf

Non-SCE Antennas

DC 222

Effective Date:

01-25-2019

What's Changed?

Sheet 9 of 10

DOH

Figure DC 222–5: Emergency RF/Power Shut-Off Switch



Figure DC 222–6: Omni-Directional Antenna and Directional Antenna

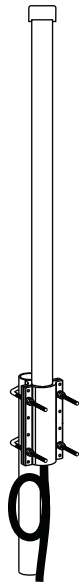

Omni-Directional Antenna

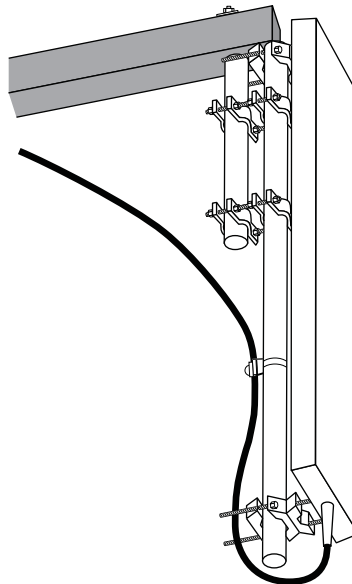

Directional Antenna

DC 321 Triplex/Dead-ends/Corners

Scope DC 321.1 Typical Secondary Construction for Triplex/Dead-ends/Corners

Figure DC 321-1: Triplex/Dead-ends/Corners

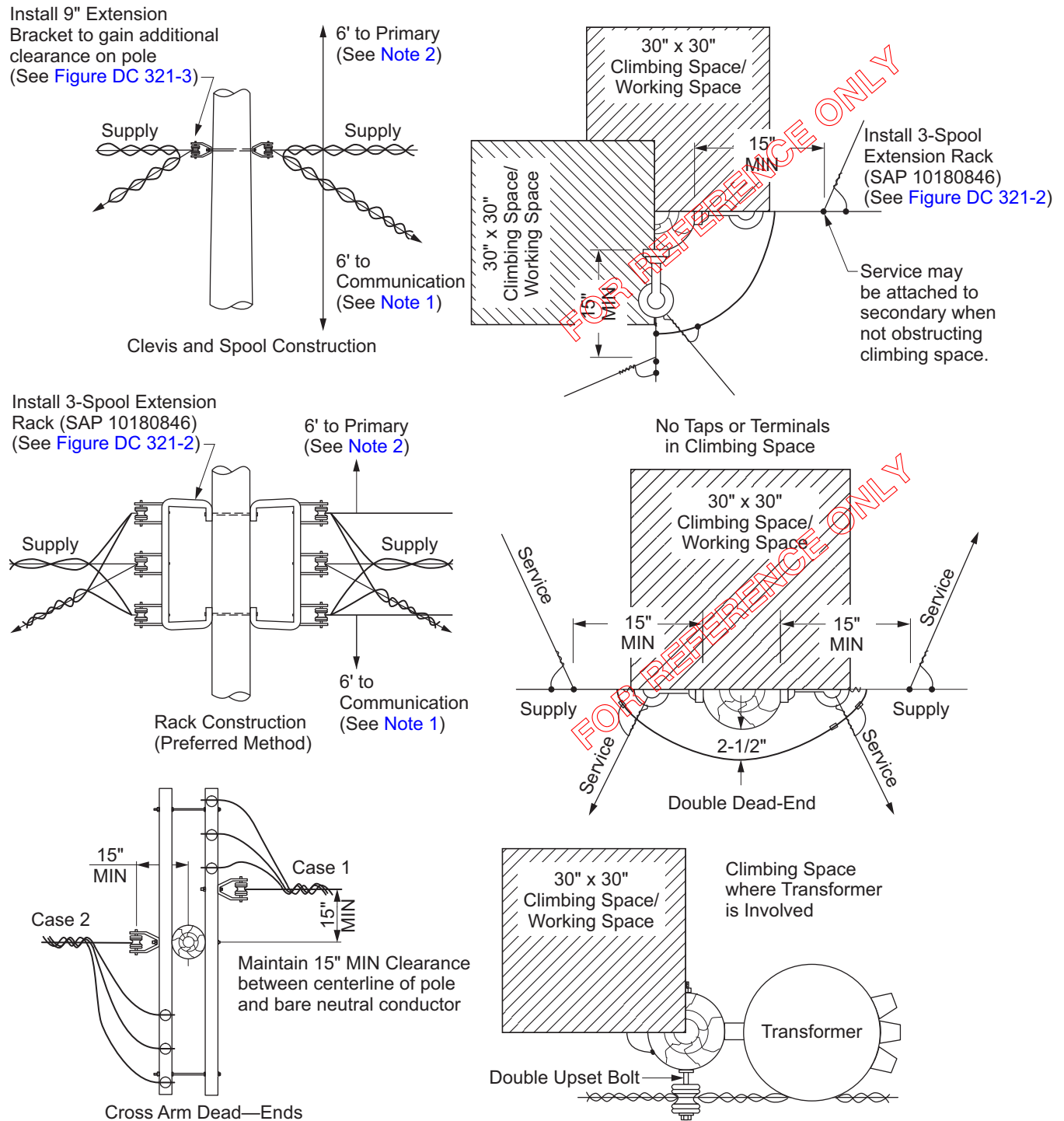

Approved by:

a/j

Triplex/Dead-ends/Corners

DC 321

Effective Date:
01-25-2019

What's Changed?

Sheet 1 of 3

DOH

Note(s):

1. May be reduced to 4 feet with installation of guard arm above communication cables attached to surface of the pole.
2. May be reduced to 4 feet with installation of guard arm, or covered with suitable protection, or installed 15 inches or more from center of pole.

Figure DC 321-2: 3-Spool Extension Rack

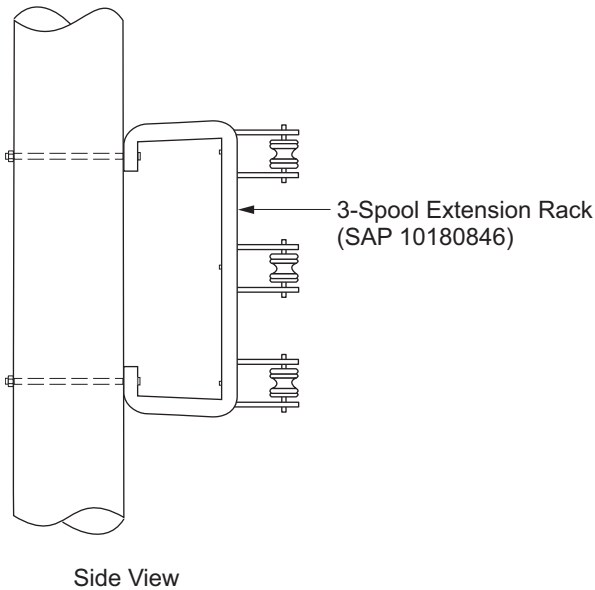

Figure DC 321-2.1: 3-Spool Extension Rack

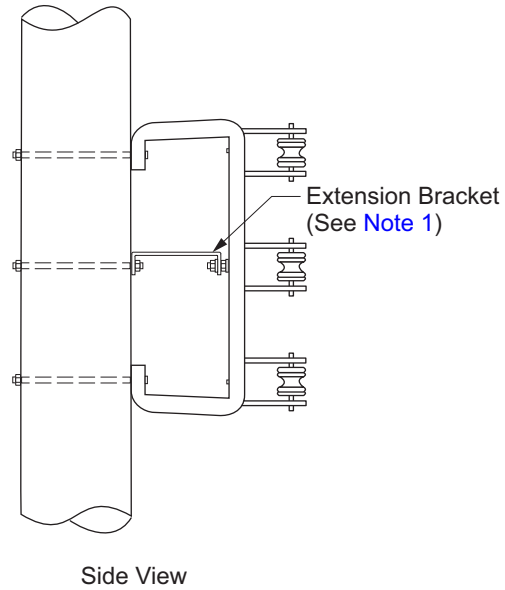

Figure DC 321-2.2: 3-Spool Extension Rack with Extension Bracket

Note(s):

1. Use the extension bracket (SAP 10209938) on center position when 1/0, 4/0 triplex, quadruplex, and 4/0 WAL is dead-ended.

Figure DC 321-3: 3-Spool Extension Rack Extension Bracket

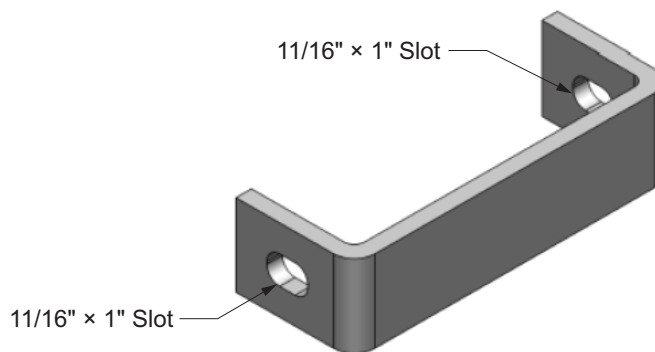
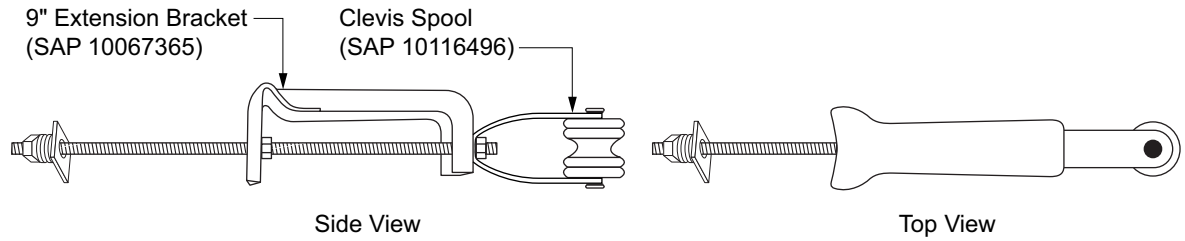

Figure DC 321-4: 9-Inch Angle Extension Bracket with Clevis Spool



Approved by:
a/j

Triplex/Dead-ends/Corners

DC 321

Effective Date:
01-25-2019

What's Changed?

Sheet 3 of 3

DOH

This page intentionally left blank.

DC 535 Wildlife-Safe Power Line Construction

Scope DC 535.1 Wildlife-Safe Power Line Construction

1.0 General Information

These standards are intended to protect lines from wildlife by constructing sufficient phase-to-phase and phase-to-ground clearances and by installing approved protective materials on high voltage lines and equipment. In addition, installing wildlife protection on all phases will mitigate other contact-related faults, such as incidental contact of trees and metallic balloons at the pole. Should it be determined at the time of design or construction that undertaking such efforts would compromise public or worker safety, reasonable efforts will be made to construct with the best possible clearances and/or protective materials.

Wildlife protection material is for incidental wildlife contact only. They are not rated for personal protection and should be treated as bare wires.

1.1 New poles, bare and covered conductor lines, equipment, apparatus, and pole replacements shall be constructed per this standard.

A. Standard Construction

- Horizontal phase-to-phase/ground separation of 36 inches and vertical phase-to-phase/ground separation of 36 inches (Measured center of pin to center of pin on a wood/composite arm) (see [Figure DC 535-1](#)).

In the absence of sufficient separation, wildlife protection material shall be used (for example, Wildlife Hoods, Wildlife Hood Extenders, and Protective Tubing).

- In covered conductor systems, wildlife protection material shall be used on all phases as well as the neutral. For example, a 4-wire dead-end construction must have dead-end wildlife protection on all four wires.
- Covered Conductor systems do not require use of wildlife hoods, wildlife hood extenders, and/or protective tubing.
- Dead-ends in covered conductor systems shall be covered with wildlife protection.
- Overhead equipment shall have bushing covers
- Overhead equipment shall be connected with covered conductors
- Overhead arresters shall utilize vendor supplied covers
- All overhead taps, leads, and jumper wires shall utilize covered conductors
- On all riser poles, potheads shall utilize covers and all phase jumpers shall be covered
- All new overhead switches shall be inverted

Approved by: 	Wildlife-Safe Power Line Construction	DC 535
Effective Date: 01-25-2019	What's Changed?	Sheet 1 of 26 DOH

B. Eagle Zone Construction

Portions of the SCE service territory are designated as Eagle Zones (see [Section 5.0](#)):

- In addition to areas defined in [Section 5.0](#), all Public Lands (for example, Forest Service, BLM, NPS, and State Parks) are designated as Eagle Zones.

In addition to the above requirements for Standard Construction, the following applies for Eagle Zone Construction:

- Horizontal phase-to-phase/ground separation of 60 inches (Measured center of pin to center of pin on a wood/composite arm, see [Figure DC 535-1](#)) and vertical phase-to-phase/ground separation of 40 inches
- In the absence of sufficient separation, wildlife protection material shall be used (for example, Wildlife Hoods, Wildlife Hood Extenders, and Protective Tubing)
- Covered Conductor systems do not require the use of Wildlife Hoods, Wildlife Hood Extenders, and Protective Tubing.

1.2 Any SCE power line structure involved in the mortality of a protected wildlife species will be evaluated by CES to determine if the SCE power line structure is wildlife safe. As appropriate, poles, lines, equipment, and apparatus involved in avian mortalities will be retrofitted with wildlife protection materials.

1.3 For the purposes of this standard, wood poles/crossarms and composite poles/crossarms are not considered “grounded”.

1.4 In areas where secondary/service drop conductors have been damaged (chewed or gnawed) by rodents and damage to the conductor has been observed, copper secondary’s shall be utilized in replacement. Aluminum secondary’s/service drops shall be replaced with copper to deter animals from re-visiting the effected line. In areas where high vegetation and rodent population exists, preventative measures like using secondary copper conductors shall be employed during the replacement of aluminum conductors. Refer to [CO 108](#) for requirements.

DC 535	Wildlife-Safe Power Line Construction	Approved by: <i>ajf</i>
Sheet 2 of 26	What's Changed?	Effective Date:
DOH		01-25-2019

2.0 Wildlife-Safe Construction for Standard Construction and Eagle Zones

2.1 4/12/16/33 kV, 3-Wire or 4-Wire, Straight-Line Construction

Figure DC 535–1: 4/12/16/33 kV, 3-Wire or 4-Wire, Straight-Line Construction

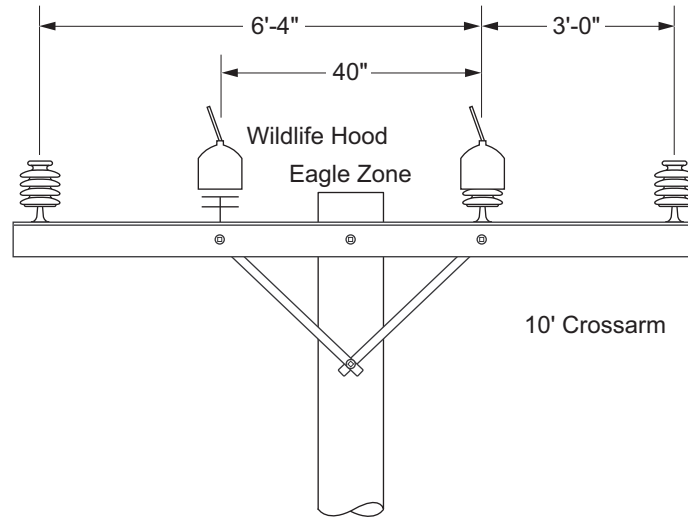

Note(s):

1. Wildlife Hoods shall be trimmed to properly fit double pin insulator application.
2. Wildlife Hoods may be installed on single pin-type insulators with a maximum of six degrees deviation angle. For double pin-type insulators the maximum deviation angle is 12 degrees with wildlife hoods trimmed to fit properly. See [DC 585](#) for determination of deviation angles.
3. In Eagle Zones, a 12 foot crossarm will require wildlife protection material or modifications to the pre-drilled holes for insulator spacing.
4. See [DC 510](#) for construction details.

Approved by: 	Wildlife-Safe Power Line Construction	DC 535
Effective Date: 01-25-2019	What's Changed?	Sheet 3 of 26 DOH

2.2 4/12/16/33 kV, 3-Wire or 4-Wire, Straight Line Post-Suspension Construction

Figure DC 535–2: 4/12/16/33 kV, 3-Wire or 4-Wire, Straight Line Pin/Post-Suspension Construction

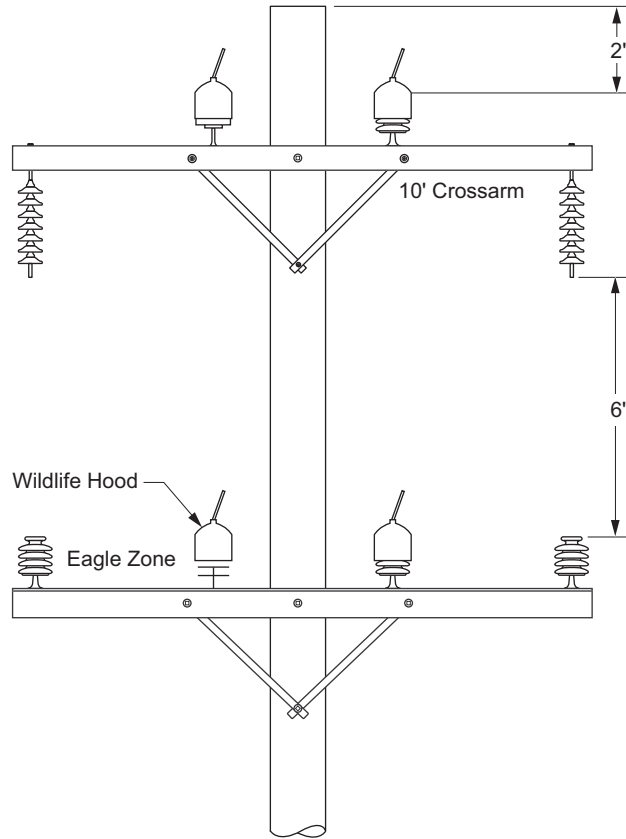

Note(s):

1. See [DC 530](#) for suspension-type construction clearances.
2. In Eagle Zones, a 12 foot crossarm will require wildlife protection material or modifications to the pre-drilled holes for insulator spacing. See [CO 700](#) for conductor spacing on 12 foot crossarms.

DC 535

Wildlife-Safe Power Line Construction

Approved by:

ajf

Sheet 4 of 26

What's Changed?

Effective Date:

DOH

01-25-2019

2.3 4/12/16/33 kV 3-Wire or 4-Wire, Two Level (Box) Construction

Figure DC 535-3: 4/12/16/33 kV, 3-Wire or 4-Wire, Two Level (Box) Construction

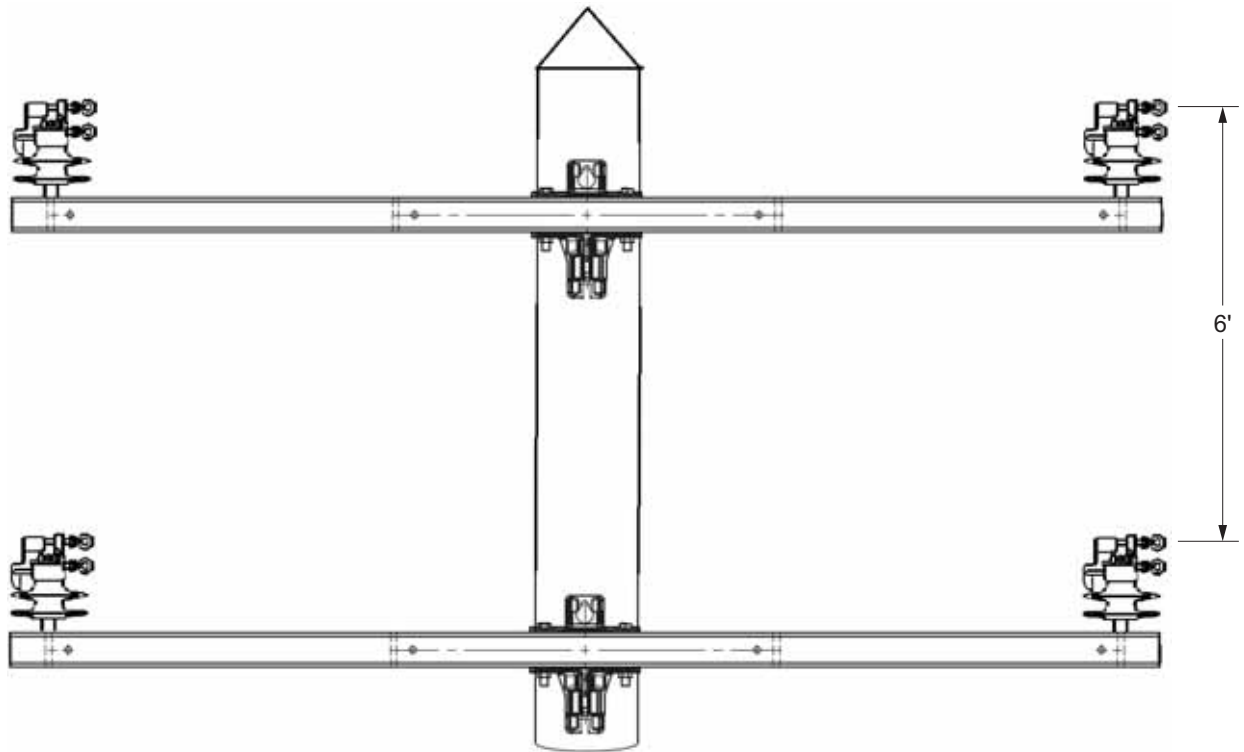

Note(s):

1. In Eagle Zones, a 12 foot crossarm will require wildlife protection material or modifications to the predrilled holes for insulator spacing. See [CO 700](#) for conductor spacing on 12 foot crossarms.
2. Insulators shown are 25 kV polymer vise-top. For 16/25 kV, use 35 kV polymer vise-top insulators (see [GR Section](#)).

Approved by: 	Wildlife-Safe Power Line Construction	DC 535
Effective Date: 01-25-2019	What's Changed?	Sheet 5 of 26 DOH

2.4 4/12/16/33 kV, 3-Wire or 4-Wire, Angle Suspension Construction

Figure DC 535-4: 4/12/16/33 kV, 3-Wire or 4-Wire, Angle Suspension Construction

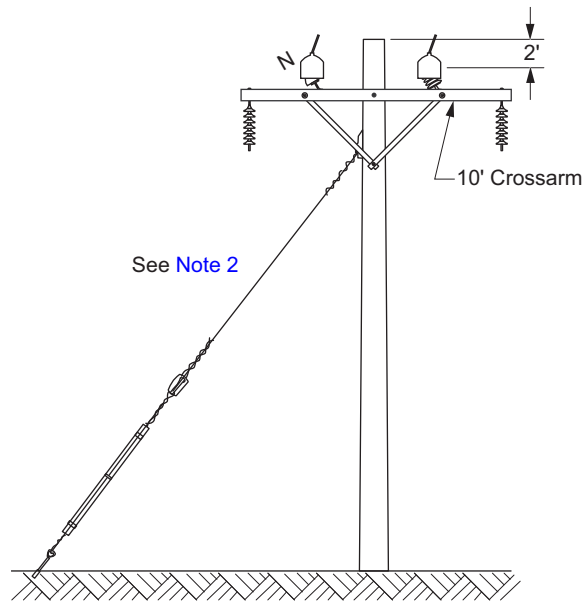

Note(s):

1. For angle deviation limits, refer to the Pole Loading Manual (PLM), Chapter PLM-4.
2. See [PO 300](#) for guying requirements.
3. In Eagle Zones, a 12 foot crossarm will require wildlife protection material or modifications to the pre-drilled holes for insulator spacing. See [CO 700](#) for conductor spacing on 12 foot crossarms.

DC 535

Wildlife-Safe Power Line Construction

Approved by:

ajf

Sheet 6 of 26

What's Changed?

Effective Date:

DOH

01-25-2019

2.5 12/16/33 kV, 3-Wire, Ridge Pin Construction

Figure DC 535-5: 12/16/33 kV, 3-Wire, Ridge Pin Construction

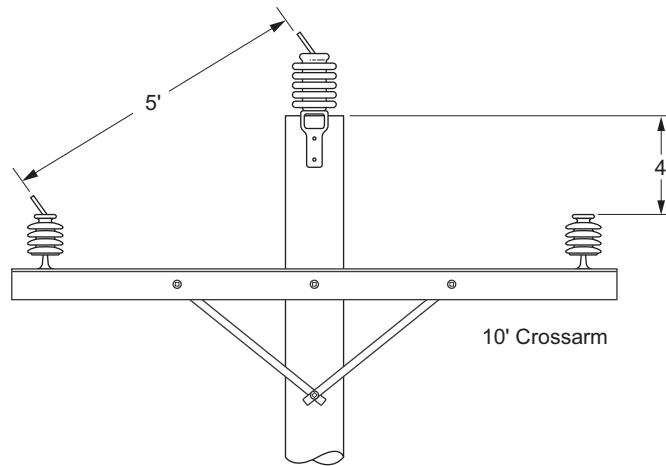

Note(s):

1. 3-Wire, Ridge Pin Construction may also be used for 12/16 kV pole replacements.
2. See [DC 500](#) for construction details.

2.6 12/16/33 kV, 3-Wire, Angled Ridge Pin Construction

Figure DC 535-6: 12/16/33 kV, 3-Wire, Angled Ridge Pin Construction

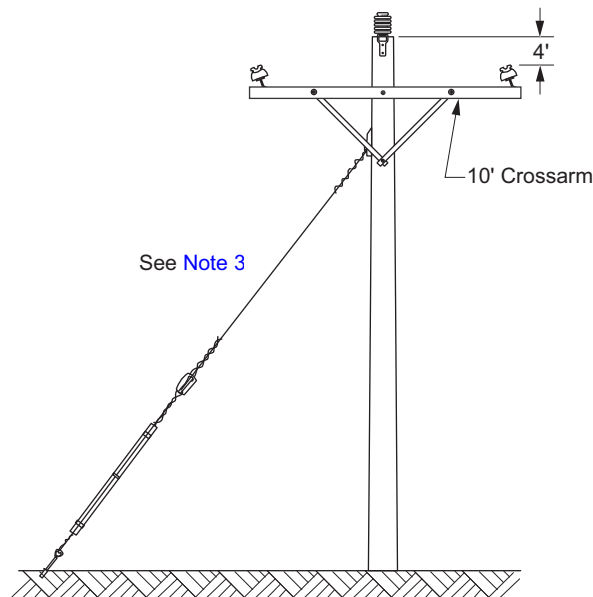

Note(s):

1. 3-Wire, Angled Ridge Pin Construction may also be used for 12/16 kV pole replacements.
2. For angle deviation limits, refer to the Pole Loading Manual (PLM), Chapter PLM-4.
3. See [PO 300](#) for guying requirements.

Approved by:

ajf

Wildlife-Safe Power Line Construction

DC 535

Effective Date:
01-25-2019

What's Changed?

Sheet 7 of 26

DOH

2.7 3-Wire or 4-Wire, Double Dead-End Construction

Figure DC 535-7: 3-Wire or 4-Wire, Double Dead-End Construction

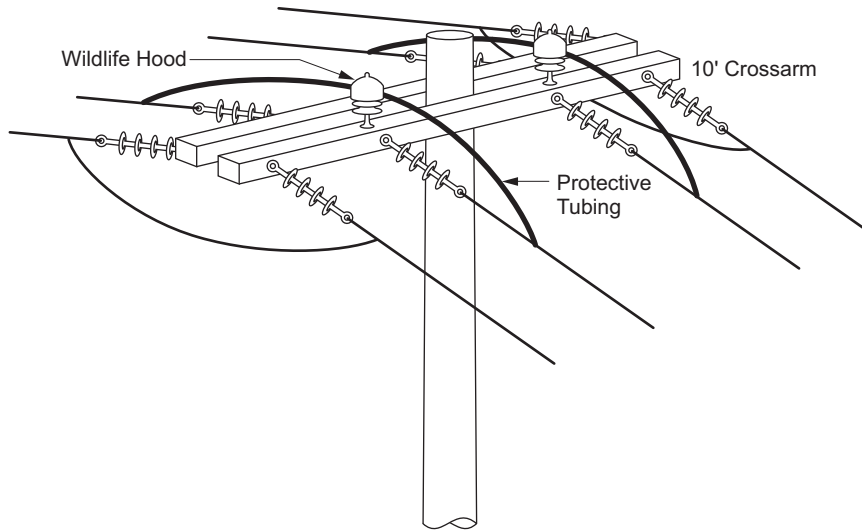

Note(s):

1. Inside phase jumper(s) shall be covered with protective tubing when installed over the crossarms.
2. In Eagle Zones, a 12 foot crossarm will require wildlife protection material or modifications to the pre-drilled holes for insulator spacing.

DC 535	Wildlife-Safe Power Line Construction	Approved by: 
Sheet 8 of 26 DOH	What's Changed?	Effective Date: 01-25-2019

2.8 3-Wire or 4-Wire, Corner Pole, Vertical Construction

Figure DC 535–8: 3-Wire or 4-Wire, Corner Pole, Vertical Construction

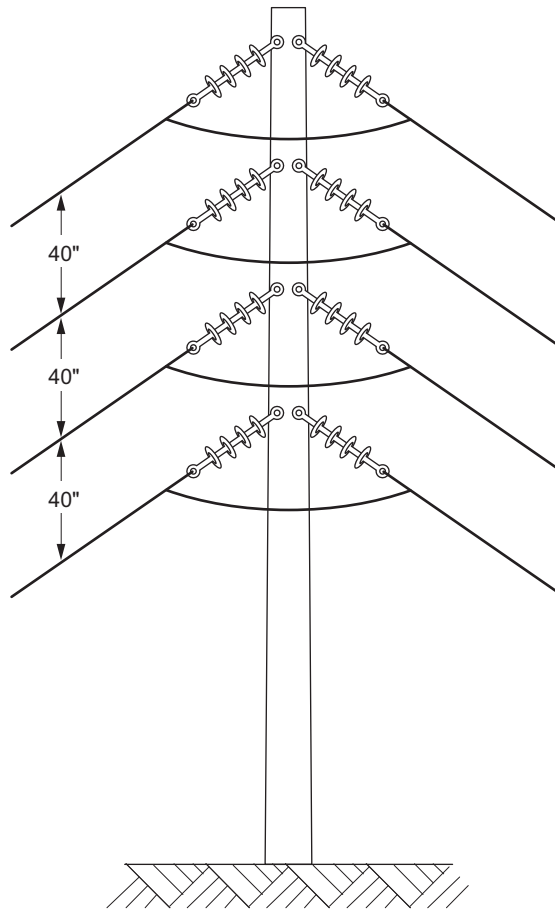

Approved by:

ajf

Wildlife-Safe Power Line Construction

DC 535

Effective Date:

01-25-2019

What's Changed?

Sheet 9 of 26

DOH

2.9 3-Wire or 4-Wire, Corner Pole, Horizontal Construction

Figure DC 535–9: 3-Wire or 4-Wire, Corner Pole, Horizontal Construction

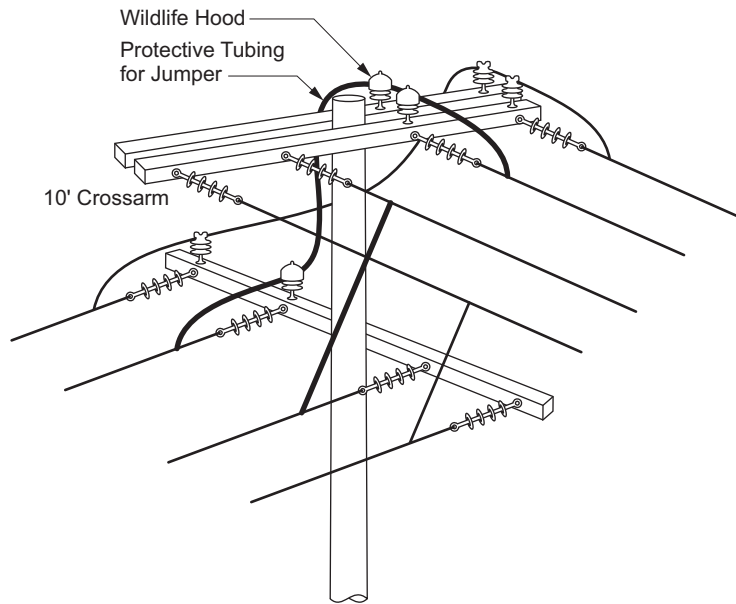

Note(s):

1. Wildlife Hoods shall be trimmed to properly fit double pin insulator application.
2. See [DC 110](#) and [DC 120](#) for proper clearances.
3. In Eagle Zones, a 12 foot crossarm will require wildlife protection material or modifications to the pre-drilled holes for insulator spacing.

2.10 12/16/25/33 kV 3/4-Wire, Transmission Underbuild

Follow [DC 530](#) for suspension construction. If suspension construction is not possible, construct to [Figure DC 535–4](#).

For steel poles utilizing crossarms to support primary conductors with less than 60 inches of horizontal phase-to-phase clearance (Measured center of pin to center of pin, see [Figure DC 535–1](#)) or 36 inches of horizontal phase-to-pole clearance (measured to the surface of the pole), all phases shall be covered.

Per [GR 111.1](#), the neutral to pole connection shall be made using a conductor with at least the same ampacity as the primary and/or secondary neutral conductor of the circuit and shall be covered with appropriate protective tubing.

DC 535 Sheet 10 of 26 DOH	Wildlife-Safe Power Line Construction	Approved by: 
	What's Changed?	Effective Date: 01-25-2019

3.0 Wildlife Protection for Apparatus

3.1 Connectors

Connectors shall be installed at a minimum of 40 inches above mounting brackets (for example, cable terminations, arresters, or fuse holders) or wildlife protection materials shall be installed.

3.2 Transformers

Transformers shall have bushing covers for primary transformer bushings (including neutrals) and covered tubing for jumpers between fuse holders. New lightning arresters come from the manufacturer with required protective covering and all high side taps on fuse holders require covered tubing and the wire shall be connected at the top of the fuse holder. Protected Ground Wire (PGW) can be used in these situations. When working on a pole with existing arresters that do not have covers, replace them with new ones that have the required covers.

3.3 Cable Terminations (Potheads)

Cable terminations shall have protective covers over the energized, upper part of the termination, and covered tubing for the termination taps. The jumper or tap area immediately adjacent to the grounded metal termination bracket and crossarm must also be adequately covered. New lightning arresters come from the manufacturer with required protective covering. When working on a pole with existing arresters that do not have covers, replace them with new ones that have the required covers.

3.4 Capacitor Banks

Capacitor banks shall have protective covering. When vendor supplied capacitor units do not include protective covers over energized parts, the exposed areas shall be covered by Field Personnel. Bushing covers and current limiting fuse covers shall be installed on potential transformers and current limiting fuses in the area closest to the high voltage transformer bushings.

3.5 Automatic Reclosers (AR), Remote Control Switches (RCS) and Regulators

ARs and regulators shall have protective covers over exposed bushings. A minimum of three feet of covered tubing shall be installed over the line taps. Bushing covers and current limiting fuse covers shall be installed on potential transformers and current limiting fuses in the area closest to the high voltage transformer bushings.

Approved by: <i>ajf</i>	Wildlife-Safe Power Line Construction	DC 535
Effective Date: 01-25-2019	What's Changed?	Sheet 11 of 26 DOH

3.6 Overhead Switches

A. Horizontal Construction

New installations requiring an overhead distribution switch (up to 17 kV class) shall be an inverted Omni-Rupter wildlife-safe switch (see AP 336). Center phase leads of the switch shall have protective covering.

38 kV class applications requiring an overhead distribution switch shall be an inverted Alduti-Rupter wildlife-safe switch. For Eagle Zones only, center phase leads of the switch shall have protective covering (see AP 338).

B. Vertical Construction

Installations requiring an overhead distribution switch (up to 17 kV class) shall be an inverted Omni-Rupter wildlife-safe switch (see AP 336).

4.0 Wildlife Protection Materials

Wildlife protection material is for incidental wildlife contact only. They are not rated for personal protection and should be treated as bare wires.

Bushing covers shall only cover top skirt of the bushing.

Table DC 535–1: Wildlife Protection Material





SAP	Description	Photo
10067758	Cover, Wildlife, Bushing, to be Used on Transformer Bushing, 3.25" to 4.25" Skirt Diameter, HDPE Material, Grey Color.	
10067783	Cover, Wildlife, Bushing, to be Used on Transformer Bushing, 4.5" Maximum Skirt Diameter, HDPE Material, Grey Color.	
10067753	Cover, Wildlife, Bushing, to be Used on Recloser and Voltage Regulator Bushing, 5.00" to 6.25" Skirt Diameter, HDPE Material, Grey Color.	
10211487	Cover, Wildlife, Dead End Clamp, HDPE Material, Grey Color	

Table DC 535-1: Wildlife Protection Material (Continued)

SAP	Description	Photo
10067793	Cover, Wildlife, Bushing, to be Used on Current Limiting Device, (CLD), Install Either Horizontal or Vertical Position, HDPE Material, Red Color.	
10200065	Cover, Wildlife, to be Used on Terminators/potheads, 4-1/2" x 8" Outside Dimensions, HDPE Material, Grey Color.	
10211426	Cover, Wildlife, to be Used on Terminators/Potheads, 350-1500 kcmil, 4-1/2" x 16" Outside Dimensions, HDPE Material, Grey Color.	
10200066	Cover, Wildlife, Brace Bolt, to be Used on Crossarms with V-braces on Steel Poles, HDPE Material, Grey Color.	
10109289	Cover, Wildlife, Stud, to be Used on Distribution Lightning Arresters, PVC Material, Grey Color.	
10184084	Cover, Wildlife, Body, Insulator, Post Type, to be Used with SAP 10067847 Extenders, Grey Color.	
10067846	Cover, Wildlife, Body, Insulator, Post and Vice-top Type, Body, to be Used with SAP 10067847 Extenders, Grey Color.	

Approved by:

ajf

Wildlife-Safe Power Line Construction

DC 535

Effective Date:

01-25-2019

What's Changed?









Sheet 13 of 26

DOH

Table DC 535–1: Wildlife Protection Material (Continued)

SAP	Description	Photo
10067847	Cover, Wildlife, Extenders for 60" Coverage, Set of 2, to be Used with SAP 10184084 or SAP 10067846 Body, Grey Color.	
10184091	Cover, Wildlife, 1-piece, 60", to be Used with Post and Vice-top Insulators, Grey Color.	
10184097	Cover, Wildlife, Cutout, Large, HDPE Material, Grey Color.	
10184093	Cover, Wildlife, Cutout — 4 kV, HDPE Material, Grey Color.	
10184094	Cover, Wildlife, Cutout — 12/16 kV, HDPE Material, Grey Color.	
10117060	Tubing, Wildlife, Non-split, to be Used on Capacitor Banks, 5/16" ID x 2' Long, 5/32" Wall Thickness, for #6 AWG Bare Cu — #2 AWG Str., PVC Material, Grey Color.	

Table DC 535-1: Wildlife Protection Material (Continued)

SAP	Description	Photo
10117061	Tubing, Wildlife, Non-split, 0.45" ID × 2' Long, 5/32" Wall Thickness, for #2/0 AWG Bare Cu — 1/0 AWG ACSR, PVC Material, Grey Color.	
10117062	Tubing, Wildlife, Non-split, 3/4" ID × 2' Long, 5/32" Wall Thickness, for 336.4 kcmil ACSR, PVC Material, Grey Color.	
10147890	Cover, Wildlife, Stinger, Split, to be Used to Cover Primary Wire, 3/8" ID × 2' Long, (25) Per Box, for #6 AWG — 1/0 ACSR, Ozone Resistant Rubber Material, Grey Color.	
10200336	Cover, Wildlife, Stinger, Split, to be Used to Cover Primary Wire, 3/8" ID × 50' Long Coil, for #6 AWG — 1/0 ACSR, Ozone Resistant Rubber Material, Grey Color.	
10180176	Cover, Wildlife, Stinger, Split, to be Used to Cover Primary Wire, 5/8" ID × 50' Long Coil, for 2/0 — 336.4 kcmil, Ozone Resistant Rubber Material, Grey Color.	
10180177	Cover, Wildlife, Stinger, Split, to be Used to Cover Primary Wire, 3/4" ID × 25' Long Coil, (2) Coils Per Box, for 653 kcmil-750 kcmil, Ozone Resistant Rubber Material, Grey Color.	
10109302	Protected Ground Wire (PGW), LDPE, #6 AWG CU to be used over taps (when applicable), high-side bushing on transformer banks and capacitor banks.	
10109304	Protected Ground Wire (PGW), LDPE, #4 AWG CU to be used over taps (when applicable), high-side bushing on transformer banks and capacitor banks.	

Approved by:
ajf

Wildlife-Safe Power Line Construction

DC 535

Effective Date: **What's Changed?**
01-25-2019

Sheet 15 of 26

DOH

Table DC 535–1: Wildlife Protection Material (Continued)

SAP	Description	Photo
10067816	Guard, Wildlife, Triangular, Adjustable, 2-1/4" x 24-1/4", Polyethylene Material, to be Mounted on Crossarms Between Phases.	

= For Reference Only

5.0 Eagle Zones

Table DC 535–2 summarizes whether a District contains Eagle Zones, which require additional conductor clearances or covers. In many Districts, both Standard Construction and Eagle Zones are identified; in these cases, the Eagle Zone Maps should be used to identify requirements for a specific area.

The Eagle Zone map designations are a collaboration between T&D and CES and are subject to change. The most recent publications and maps should always be referenced prior to Planning or Construction.

Eagle Zone maps are broken down by districts and may be found at the link below:

[Eagle Zone Maps](#)

Table DC 535–2: Districts and Eagle Zone

Region	District #	District Name	Standard Construction	Eagle Zone	Eagle Construction Zone
Catalina	61	Catalina	X	X	Entire island except the portion of the city of Avalon within a line beginning at Crescent Ave. and Claressa Ave.; going south on Claressa Ave. to Tremont St. West on Tremont to Country Club Dr., North on Country Club and Las Lomas to Crescent Ave.; and East to point of origin.
Desert	30	Foothill	X	X	Areas of Foothill district on north of the 210 FWY and West of the 15 FWY.
Desert	31	Redlands	X	X	Outside a boundary starting on: 1. N/E of 215 FWY and Devore Rd. going S/E on Kendall Dr. to Campus Pkwy. 2. Going N/E on Campus Pkwy to W Northpark Blvd. 3. South/East on W Northpark Blvd. to Electric Ave. 4. South on Electric Ave. to 40th St. 5. East on 40th St. to Mountain Ave. 6. South on Mountain Ave. to 39th St. 7. East on 39th St. to Del Rosa Ave. 8. South on Del Rosa Ave. to Foothill Dr. 9. East on Foothill Dr. to Sterling Ave. 10. South on Sterling Ave. to Lynwood Dr. 11. East on Lynwood Dr. to Victoria Ave. 12. South on Victoria Ave. to Highland Ave. 13. East on Highland Ave. to Church St. 14. South on Church St. to side of the Santa Ana River. 15. Santa Ana River East to Crafton 16. South on Crafton to Sand Canyon. 17. East on Sand Canyon to Chapman Heights Rd. 18. West on Chapman heights Rd. to Oak Glen Rd. 19. East on Oak Glen Rd. to Bryant St.

Table DC 535–2: Districts and Eagle Zone (Continued)

Region	District #	District Name	Standard Construction	Eagle Zone	Eagle Construction Zone
Desert (cont'd)	31	Redlands	X	X	<p>Outside a boundary starting on:</p> <ol style="list-style-type: none"> 20. South on Bryant St. to Ave. F. 21. East on Ave. F to Mesa Grande Dr. 22. South Mesa Grande Dr. to County Line Rd. 23. West on County Line Rd. to Fremont St. 24. South on Fremont to Ave L. 25. West on Ave. L to California St. 26. South on California St. to Myrtlewood Dr. 27. West on Myrtlewood Dr. to Calimesa Blvd. 28. South on Calimesa Blvd. to the 10 FWY. 29. West on 10 FWY to Highland Ave. 30. West on Highland Ave. to Smiley Heights Dr. 31. West on Smiley Heights Dr. to Terracina Blvd. 32. North on Terracina Blvd. to Barton Rd. 33. West on Barton Rd. to the district boundary. 34. East of Mt. Vernon Ave. and Washington St. 35. South on Mt. Vernon Ave. to Palmyrita Ave. 36. Undeveloped areas South/East of the intersection of the 215 FWY and 10 FWY.
Desert	73	Victorville (aka High Desert)	X	X	<p>Outside a boundary beginning on the intersection of 15 FWY and Rancho Rd.</p> <ol style="list-style-type: none"> 1. North on 15 FWY to 395. 2. North on 395 to Rancho Rd. 3. East on Rancho Rd. to 18 HWY. 4. S/E on 18 HWY to Navajo Rd. 5. South on Navajo Rd. to Bear Valley Rd. 6. West on Bear Valley Rd. to Deep Creek Rd.

DC 535

Wildlife-Safe Power Line Construction

Approved by:

ajf

Sheet 18 of 26

What's Changed?

Effective Date:

DOH

01-25-2019

Table DC 535–2: Districts and Eagle Zone (Continued)

Region	District #	District Name	Standard Construction	Eagle Zone	Eagle Construction Zone
Desert (cont'd)	73	Victorville (aka High Desert)	X	X	Outside a boundary beginning on the intersection of 15 FWY and Rancho Rd. 7. South of Deep 8 Creep Rd. to Juniper Rd. 8. West on Juniper Rd. to Rancho Rd. 9. West on Rancho Rd. to 15 FWY.
Desert	79	Palm Springs	X	X	Outside the boundaries between the 10 FWY and HWY 111.
Metro East	22	Montebello	X	—	—
Metro East	26	Covina	X	X	All areas North of a line beginning at intersection of HWY 39 and Foothill Blvd., proceeding East along Foothill Blvd. to Valley Center, South on Valley Center to Route 66, East on Route 66 to Baseline Rd, East on Baseline Rd. to 210 FWY.
Metro East	27	Monrovia	X	X	All the area North of a line beginning on Encanto Pkwy and Huntington Dr. 1. West on Huntington Dr. to Mountain Ave. 2. North on Mountain Ave. to Foothill Blvd. 3. West on Foothill Blvd. to Michillinda Ave. 4. North on Michillinda Ave. to Park Vista Dr. 5. All Area of Sierra Madre, Altadena, La Canada Flintridge, and La Crescenta.
Metro East	34	Ontario	X	—	All district areas North of the 210 FWY. "Eagle zone with Exceptions" 1. Within the boundaries of Ontario district on South of 60 FWY and West of 71 FWY.

Approved by:



Wildlife-Safe Power Line Construction

DC 535

Effective Date:

01-25-2019

What's Changed?

Sheet 19 of 26

DOH

Table DC 535-2: Districts and Eagle Zone (Continued)

Region	District #	District Name	Standard Construction	Eagle Zone	Eagle Construction Zone
Metro East (cont'd)	34	Ontario	X	X	<p>Within a boundary beginning on intersection of 71 FWY and Edison.</p> <ol style="list-style-type: none"> 1. East on Edison Ave. to 15 FWY. 2. South on 15 FWY to Limonite Ave. 3. East on Limonite Ave. to Van Buren Blvd. 4. South on Van Buren Blvd. to Santa Ana River. 5. West on Santa Ana River trail to North Dr. 6. West on North Dr. to California Ave. 7. South on California Ave. to Sixth St. 8. West on Sixth St/Norco Dr./Corydon Ave. to River Rd. 9. S/E on River Rd. to Lincoln Ave. 10. South on Lincoln Ave. to Foothill Pkwy. 11. East on Foothill Pkwy to 15 FWY. 12. North on 15 FWY to Magnolia Ave. 13. N/E on Magnolia Ave. to Pierce St. 14. South on Pierce St. to Indiana Ave. 15. All undeveloped areas North and West of Lake Matthews.
Metro West	32	Dominguez Hills	X	—	—
Metro West	42	Santa Monica	X	—	—
Metro West	44	South Bay	X	—	—
Metro West	46	Long Beach	X	—	—
Metro West	47	Whittier	X	—	—
North Coast	35	Thousand Oaks	X	X	North of the 101 FWY, and undeveloped areas outside cities of Moorpark, Simi Valley, and Thousand Oaks.

DC 535

Wildlife-Safe Power Line Construction

Approved by:

ajf

Sheet 20 of 26

What's Changed?

Effective Date:

DOH

01-25-2019

Table DC 535–2: Districts and Eagle Zone (Continued)

Region	District #	District Name	Standard Construction	Eagle Zone	Eagle Construction Zone
North Coast	36	Antelope Valley	X	X	<p>Outside a boundary beginning on intersection of Ave. I and 60th St. W.</p> <ol style="list-style-type: none"> 1. South to 60th St. to W Ave. N. 2. East on W Ave. N to 30th St. 3. South on 30th St. to Rancho Vista Blvd. 4. East on Rancho Vista Blvd. to 20th St. 5. South on 20th St. to Elizabeth Lake Rd. 6. East on Elizabeth Lake Rd. to Tierra Subida Ave. 7. South on Tierra Subida Ave. to Ave. S 8. East on Ave. S to 40th St. 9. North on 40th St. to Ave. I. 10. West on Ave. I to 60th St. <p>Outside a boundary beginning on intersection of 150th St. and Palmdale Blvd.</p> <ol style="list-style-type: none"> 1. East on Palmdale Blvd to 180th St. 2. North on 180th St. to Ave M 8. 3. West on Ave M 8 to 150th St. 4. South on 150th to Palmdale Blvd.
North Coast	39	Ventura	X	X	<p>North of a line beginning on 33 FWY and Main St.</p> <ol style="list-style-type: none"> 1. S/E on Main to Telegraph Rd. 2. East on Telegraph Rd. to 118 (Wells Rd.) 3. South on 118 (Wells Rd.) to Railroad 4. South/West on Railroad to 101 FWY 5. S/E on 101 FWY to Beardsley Rd. <p>All undeveloped areas North of City of Camarillo.</p>
North Coast	49	Santa Barbara	X	X	<p>North of a boundary beginning from HWY 192 and HWY 150.</p> <ol style="list-style-type: none"> 1. West on 192/Cathedral Oaks to 1 FWY.

Table DC 535–2: Districts and Eagle Zone (Continued)

Region	District #	District Name	Standard Construction	Eagle Zone	Eagle Construction Zone
North Coast	59	Valencia	X	X	All Area outside the boundaries beginning from intersection of 5 FWY and HWY 14. <ol style="list-style-type: none"> 1. N/E on 14 to Soledad Canyon Rd. 2. West on Soledad Canyon Rd. to Whites Canyon Rd. 3. North on Whites Canyon Rd./ Plum Canyon Rd. to bouquet Canyon Rd. 4. North on Bouquet Canyon Rd. to Copper Hill Dr. 5. West on Copper Hill Dr. to Newhall Ranch Rd. 6. West on Newhall Ranch Rd. to 5 FWY. 7. Undeveloped areas west of the 5 FWY to HWY 14.
Orange	29	Santa Ana	X	—	—
Orange	33	Huntington Beach	X	—	—
Orange	43	Saddleback	X	X	East of the 241 FWY within the district boundaries. Starting on 241 FWY and Santiago Canyon Rd.
Orange	48	Fullerton	X	—	—
Rurals North	50	Shaver Lake	—	X	—
Rurals North	52	Tehachapi	X	X	Outside the boundaries beginning from 58 HWY and Tucker Rd. <ol style="list-style-type: none"> 1. South on Tucker Rd. to Highline Dr. 2. East on Highline Dr. to Dennison Rd. 3. North on Dennison Rd. to 58 HWY. 4. West on 58 HWY to Tucker.
Rurals North	53	Kernville	—	X	All district
Rurals North	85	Bishop/Mammoth	—	X	All district

DC 535

Wildlife-Safe Power Line Construction

Approved by:

ajf

Sheet 22 of 26

What's Changed?

Effective Date:

DOH

01-25-2019

Table DC 535–2: Districts and Eagle Zone (Continued)

Region	District #	District Name	Standard Construction	Eagle Zone	Eagle Construction Zone
Rurals North	86	Ridgecrest	X	X	<p>Outside the boundaries beginning from intersection of Inyokern Rd. and Mahan St.</p> <ol style="list-style-type: none"> 1. South on Mahan St. to Dolphin Ave. 2. East on Dolphin Ave. to College Heights Blvd. 3. North on College Height Blvd. to Bowman Rd. 4. East on Bowman Rd. to Gateway Blvd. 5. North on Gateway Blvd. to Ridgecrest Blvd. 6. West on Ridgecrest Blvd. to China Lake Blvd. 7. North on China Lake Blvd. to Inyokern Rd. 8. West on Inyokern Rd. to Mahan St.
Rurals South	40	Arrowhead	—	X	All district
Rurals South	72	Barstow	X	X	<p>Outside the boundaries beginning on intersection of Main St. and P St.</p> <ol style="list-style-type: none"> 1. South on P St. to Linda Vista Ave. 2. East on Linda Vista Ave. to H St. 3. North on H St. to Rimrock Rd. 4. East on Rimrock Rd. to Montana Rd. 5. North on Montana Rd. to Main St. 6. West on Main St. to P St.
Rurals South	84	29 Palms (aka Yucca Valley)	X	X	<p>Outside the boundaries of 29 Palms.</p> <ol style="list-style-type: none"> 1. Boundary beginning on Intersection of HWY 62 and Encila Ave. 2. North on Encila Ave. to Samarkan Dr. 3. East on Samarkan Dr. to Morongo Rd. 4. South on Morongo Rd. to 2 mile Rd. 5. East on 2 mile Rd. to Utah Trail 6. South on Utah Trail to HWY 62 7. West on Hwy 62 to Encila Ave.

Approved by:



Wildlife-Safe Power Line Construction

DC 535

Effective Date:

01-25-2019

What's Changed?

Sheet 23 of 26

DOH

Table DC 535–2: Districts and Eagle Zone (Continued)

Region	District #	District Name	Standard Construction	Eagle Zone	Eagle Construction Zone
Rurals South (cont'd)	84	29 Palms (aka Yucca Valley)	X	X	<p>Outside the boundaries of Yucca Valley.</p> <ol style="list-style-type: none"> 1. Boundary beginning on Intersection of HWY 62 Kickapoo Trail. 2. South on Kickapoo Trail to Golden Bee Dr. 3. East on Golden Bee Dr. to Sage Ave. 4. South on Sage Ave. to San Andreas Rd. 5. East on San Andreas Rd. to Palomar Ave. 6. North on Palomar Ave. to HWY 62. 7. East on HWY 62 to Kickapoo trail
Rurals South	87	Blythe	X	X	<p>Outside the boundaries Blythe beginning on:</p> <ol style="list-style-type: none"> 1. Intersection of Defrain Blvd. and of 10th Ave. 2. South on Defrain Blvd to Seeley Ave. 3. East on Seeley to Intake Blvd. 4. North on Intake Blvd. to 10th Ave. 5. West on 10th Ave to Defrain Blvd.
San Jacinto	77	Menifee (formerly San Jacinto)	X	X	All district under Eagle Zone with exceptions
San Jacinto	88	Wildomar (formerly San Jacinto)	X	X	All district under Eagle Zone with exceptions
San Joaquin	51	San Joaquin	X	X	<p>Outside Boundaries city of Tulare.</p> <ol style="list-style-type: none"> 1. Intersection of Cartmill Ave. and West St. 2. South on West St. to Bardsley Ave. 3. East on Bardsley Ave. to Mooney Rd. 4. North on Mooney Rd. to Cartmill Ave. 5. West on Cartmill Ave. to West St.

DC 535

Wildlife-Safe Power Line Construction

Approved by:

ajf

Sheet 24 of 26

What's Changed?

Effective Date:

DOH

01-25-2019

Table DC 535-2: Districts and Eagle Zone (Continued)

Region	District #	District Name	Standard Construction	Eagle Zone	Eagle Construction Zone
San Joaquin (cont'd)	51	San Joaquin	X	X	<p>Outside Boundaries city of Visalia.</p> <ol style="list-style-type: none"> 1. Intersection of Riggan Ave. and Akers St. 2. South on Akers St. to Caldwell Ave. 3. East on Caldwell Ave/Ave 280 to Rd. 140. 4. North on Rd. 140 to Johns Pkwy. 5. West on Johns Pkwy to Riggan Ave. 6. West on Riggan Ave. to Akers St. <p>Outside the Boundaries of city of Hanford.</p> <ol style="list-style-type: none"> 1. Intersection of Fargo Ave. and 12th Ave. 2. South on 12th Ave. to Hanford Armona Ave. 3. East on Hanford Armona Ave. to 9-1/2 Ave. 4. North on 9-1/2 Ave. to Fargo Ave. 5. West on Fargo Ave. to 12th St. <p>Outside boundaries city of Delano:</p> <ol style="list-style-type: none"> 1. Intersection of County HWY 44 and Stradley Ave. 2. South on Stradley Ave. to Kernell Ave. 3. East on Kernell Ave. to Browning Rd. 4. North on Browning Rd. to County HWY 44. 5. West on County HWY 44 to Stradley Ave.

Table DC 535–2: Districts and Eagle Zone (Continued)

Region	District #	District Name	Standard Construction	Eagle Zone	Eagle Construction Zone
San Joaquin (cont'd)	51	San Joaquin	X	X	<p>Outside boundaries city of Porterville.</p> <ol style="list-style-type: none"> 1. Intersection of Westfield Ave. and Rd. 224 2. South on Rd. 224 to Poplar Ave. 3. East on Poplar Ave. to Plano St. 4. North on Plano St. to Westfield Ave. 5. West on Westfield Ave. to Rd. 224. <p>Outside boundaries city of Exeter.</p> <ol style="list-style-type: none"> 1. Intersection of Vine St. and Belmont Rd. 2. South on Belmont Rd. to Glaze Ave. 3. East on Glaze Ave. to 65 HWY. 4. North on 65 HWY to Ave. 276. 5. East on Ave. 275 to Gill Rd. 6. North on Gill Rd. to Palm Dr. 7. West on Palm Dr. to Valencia Dr. 8. North on Valencia Dr. to Sequoia Dr. 9. West on Sequoia Dr. to Rd. 192 10. South on Rd. 192 to Vine St. 11. West on Vine St. to Belmont Rd. <p>Outside boundaries city of Lindsay.</p> <ol style="list-style-type: none"> 1. Intersection of Tulare Rd. and Westwood Ave. 2. South on Westwood Ave. to Apia St/ Valencia St. 3. East on Apia/Valencia St. to Foothill Ave. 4. North on Foothill Ave. to Fir St. 5. West on Fir St. to Sequoia Ave. 6. South on Sequoia Ave. to Tulare Rd. 7. West on Tulare Rd. to Westwood Ave.

DC 535

Wildlife-Safe Power Line Construction

Approved by:

ajf

Sheet 26 of 26

What's Changed?

Effective Date:

DOH

01-25-2019

Table DC 535-2: Districts and Eagle Zone (Continued)

Region	District #	District Name	Standard Construction	Eagle Zone	Eagle Construction Zone
San Joaquin (cont'd)	51	San Joaquin	X	X	Outside boundaries city of Farmsville. 1. Intersection of Tulare St. and Virginia Ave. 2. North on Virginia Ave. to Ave. 228. 3. East on Ave. 228 to Farmsville Blvd. 4. South on Farmsville Blvd. to Railroad. 5. East on Railroad to Brundage Ave. 6. South on Brundage Ave. to HWY J20. 7. West on HWY J20 to Edge of Orchards. 8. South on Orchards to Tulare St. 9. West on Tulare St. to Virginia Ave.

Note(s): Eagle Zones with Exception Rules

1. Standard Construction
 - a. Development on both sides of the street or pole line
 - b. Less than approximately 40 acres of open space on either side of a street or pole line
 - c. Open space such as groomed parkland or golf courses
2. Eagle Construction
 - a. Greater than approximately 40 acres of open space on either side of a street or pole line
 - b. In situations that aren't clearly defined above as Standard Construction (when in doubt)

DC 535
Sheet 28 of 26
DOH

Wildlife-Safe Power Line Construction

Approved by:
ajf

Effective Date:
01-25-2019

DOH-GR: Grounding Bonds and Insulators

TABLE OF CONTENTS

<u>STANDARD</u>	<u>TITLE</u>
GR 100	Grounding — General Requirements
GR 100.1	Grounding Applications Involving Wood Poles
GR 103	Grounding — Lightweight Steel Poles
GR 103.1	Grounds and Attachments Made to Lightweight Steel Poles
GR 105	Grounding — Wood Poles
GR 105.1	Preferred Grounding Installation on Wood Poles Using Protected Ground Wire (PGW) with Integral Protective Covering
GR 105.2	Alternate Grounding Installation on Wood Poles Using Wood Molding and Bare Ground Wire
GR 106	Transformer Ground Conductor Size Requirements
GR 106.1	Transformer Ground Conductor Size Requirements
GR 106.2	Grounding of Subtransmission Light Duty Steel Poles
GR 107	Method of Securing Surge Arrester Ground under the Crossarm
GR 107.1	Method of Securing Surge Arrester Ground under the Crossarm
GR 110	Establishing Neutral Grounds — 4-Wire System
GR 110.1	Establishing Neutral Grounds — 4-Wire System
GR 111	Electrical Connection of Neutral Conductors to Lightweight Steel (LWS) Poles
GR 111.1	Electrical Connection of Neutral Conductors to LWS Poles
GR 120	Secondary Grounds on Transformers
GR 120.1	Secondary Grounds on Transformers
GR 200	Pin-Type Line Insulators
GR 200.1	Porcelain Pin-Type Line Insulators
GR 200.2	Polymer Pin-Type Line Insulators — Tie Top
GR 200.3	Polymer Pin-Type Line Insulators — Vice-Top, Aluminum Inserts
GR 200.4	Polymer Pin-Type Line Insulators — Vice-Top, Bronze Inserts
GR 200.5	Polymer Pin-Type Line Insulators — Vice-Top, Nylon Inserts
GR 200.6	Pin-Type Insulator Installation Instructions
GR 200.7	Polymer Pin Type Line Insulators — Clamp Top with Universal Inserts
GR 205	Post-Type Line Insulators
GR 205.1	Porcelain Post-Type Line Insulators — Tie-Top
GR 205.2	Porcelain Post-Type Line Insulators — Trunnion-Top
GR 205.3	Polymer Post-Type Line Insulators — Clamp-Top
GR 205.4	Polymer Post-Type Line Insulators — Trunnion-Top
GR 205.5	Porcelain and Polymer Post-Type Insulator Installation Instructions
GR 210	Line Insulators — Dead-Ends
GR 210.1	Typical Dead-end Type Insulators

Approved by:	Grounding Bonds and Insulators Table of Contents	GR
Effective Date:		Sheet 1 of 2
01-25-2019		DOH

<u>STANDARD</u>	<u>TITLE</u>
GR 215	Contamination Area Map
GR 215.1	Contamination Area Map
GR 300	Bonding Requirements 12 kV to 115 kV
GR 300.1	Requirements for Bonding of 12 kV to 115 kV Line Hardware
GR 305	Bonding Methods 12 kV to 66 kV
GR 305.1	Bonding Methods 12 kV to 66 kV

GR	Grounding Bonds and Insulators Table of Contents	Approved by: <i>ajf</i>
	Sheet 2 of 2	Effective Date: 01-25-2019
DOH		

GR 110 Establishing Neutral Grounds — 4-Wire System

Scope GR 110.1 Establishing Neutral Grounds — 4-Wire System

Figure GR 110-1: Establishing Neutral Grounds — 4-Wire System

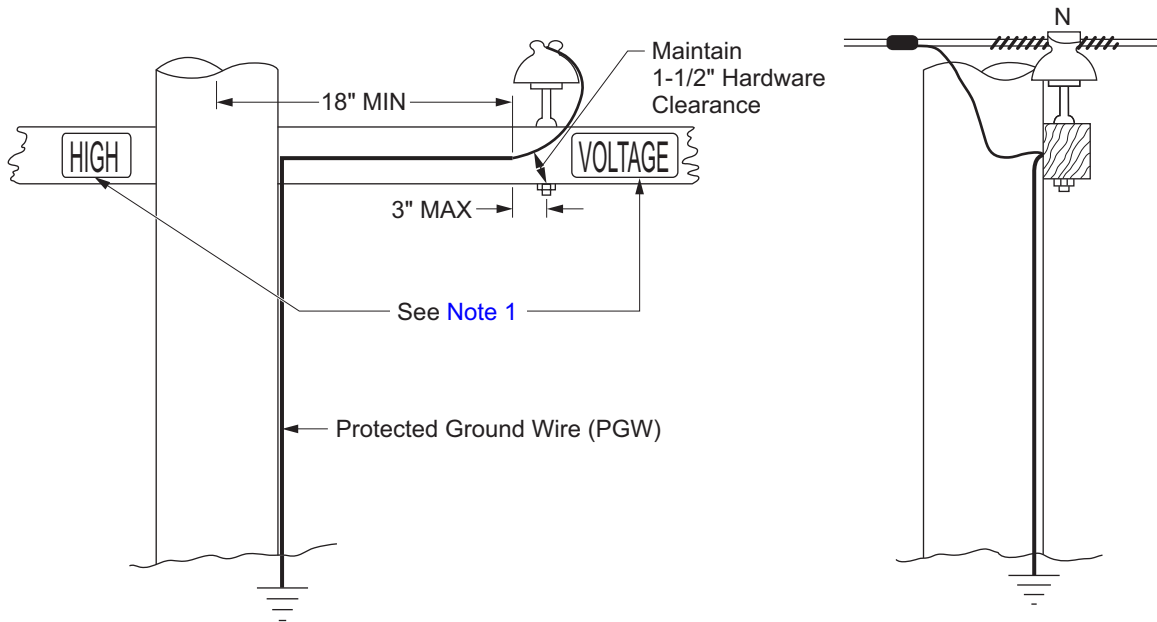

Figure GR 110-1.1: Preferred Method

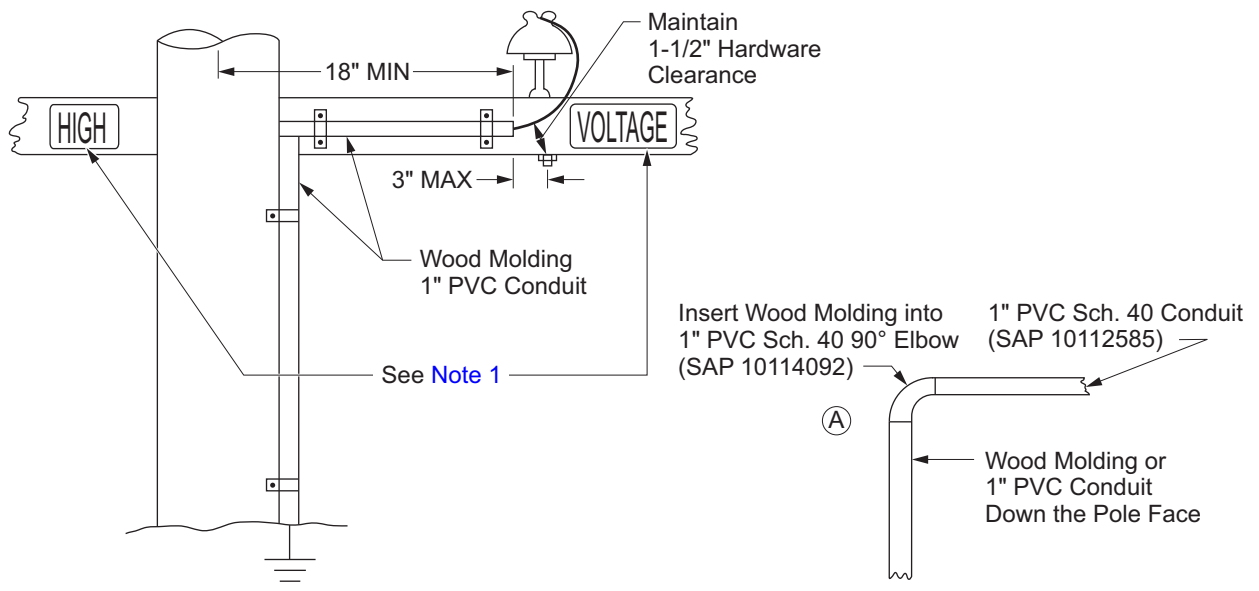

Figure GR 110-1.2: Alternate Method 1

Approved by:

ajf

Establishing Neutral Grounds — 4-Wire System

GR 110

Effective Date:
10-27-2017

What's Changed?

Sheet 1 of 3

DOH

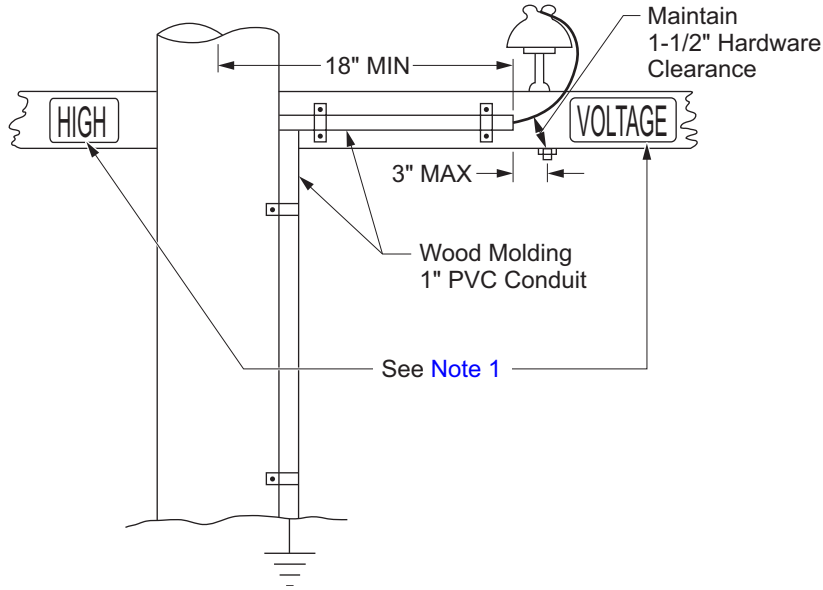



Figure GR 110–1.3 Alternate Method 2

Note(s):

1. See [PO 120](#) for HIGH VOLTAGE sign installation requirements.
2. Primary neutral ground is to be located every 1,200 feet or less for 12/6.9 kV and 16.4/9.4 kV 4-wire circuits.
3. This spacing applies to the entire circuit, including the feeder and all tap lines. Each tap line, two spans or longer on 4 kV, shall be grounded at its outer ends.

GR 110 Sheet 2 of 3 DOH	Establishing Neutral Grounds — 4-Wire System	Approved by: 
	What's Changed?	Effective Date: 10-27-2017

Scope GR 110.2 4 kV Common Neutral System

The neutral conductor of a 4 kV primary circuit shall not be interconnected with the neutral conductor of a 0–750 Volts secondary circuit, except on existing “common-neutral” systems. No new “common-neutral” system shall be established without FE approval. Extension from existing “common-neutral” systems shall be reviewed by FE to determine “common-neutral” requirements. Where surge arresters are present with “common-neutral” construction, the surge arrester ground shall be separately grounded from the “common-neutral” ground.

A common neutral sign (SAP 10135292) on the crossarm at the primary neutral position facing the climbing space (see Figure GR 110–2) is required when both primary and secondary neutrals are connected together.

Figure GR 110–2: Common Neutral Sign

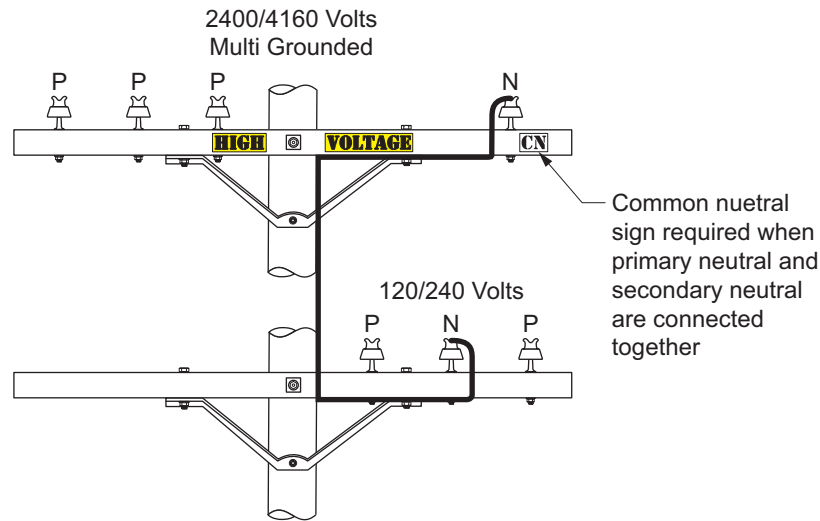

Approved by:

a/j

Establishing Neutral Grounds — 4-Wire System

GR 110

Effective Date:
10-27-2017

What's Changed? New scope clarifying 4 kV common neutral signs.

Sheet 3 of 3

DOH

This page intentionally left blank.

GR 200 Pin-Type Line Insulators

Scope GR 200.1 Porcelain Pin-Type Line Insulators

Figure GR 200-1: Porcelain Pin-Type Insulators

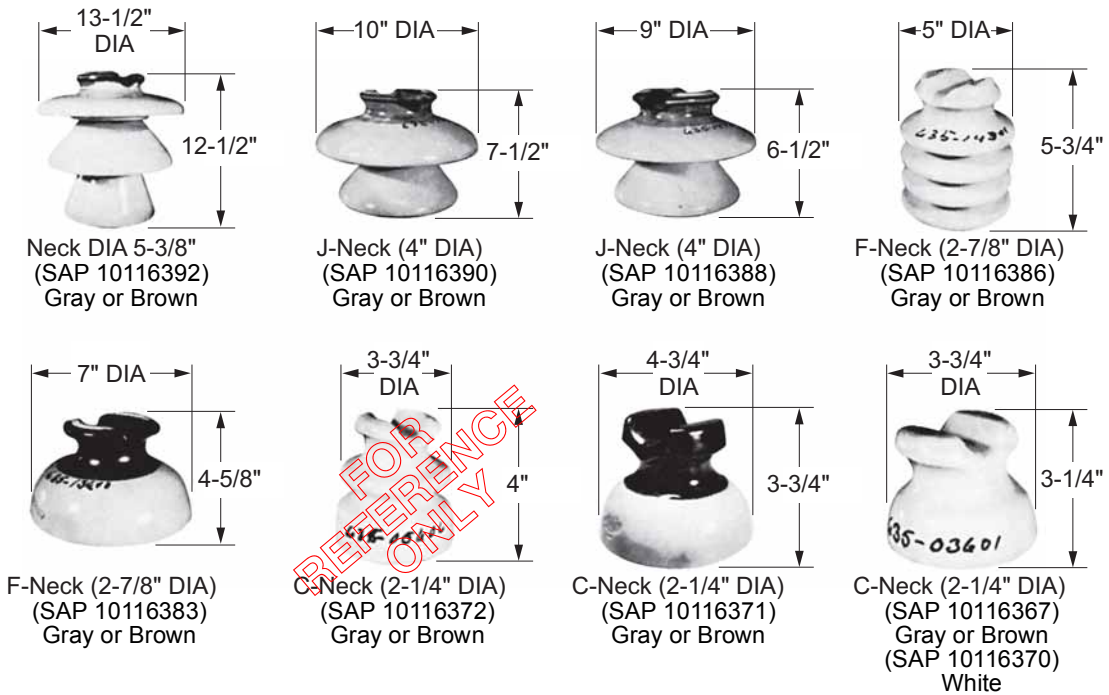

Note(s):

1. For Porcelain Pin-Type Installation details see Scope [GR 200.3, Section 1.0](#).
2. See [GR 215](#), insulation area map.
3. Not for use with covered conductor.

Approved by: <i>ajf</i>	Pin-Type Line Insulators	GR 200
Effective Date: 01-25-2019	What's Changed?	Sheet 1 of 8
		DOH

Table GR 200-1: Porcelain Pin-Type Insulators

Line Voltage (kV)	Insul. Area ^{a/}	Conductor	Nom. kV Rating	SAP	Insulator Pins	
					Vertical Pin SAP	Angle Pin SAP
33	B, C	Phase	45	10116390	10068306	10068299
16	A ^{b/} , B, C	Phase	35	10116388	10068306	10068299
	A ^{b/} , B, C	Neutral	23	10116383	10068303	10068298
12	A ^{b/}	Phase	35	10116388	10068306	10068299
	B, C	Phase	27	10116386	10068306	10068299
	A ^{b/} , B, C	Neutral	23	10116383	10068303	10068298
	(Note) ^{c/}	Neutral	13	10116371	10068303	10068298
4 or less	(Note) ^{d/}	Phase	13	10116371	10068303	10068298
	A, B, C	Phase	7	10116367	10068303	10068298
	A, B, C	Neutral	7	10116370	10068303	10068298
St. Light (6.6 Amp)	A, B, C		13	10116371	10068303	10068298

^{a/} New units purchased will be gray; however, brown units may be supplied by the re-use of returned units.

^{b/} For 25 kV, use 12 kV or 16 kV type A insulator.

^{c/} With Region approval, SAP 10116383 may also be used on phase conductors in Northwestern and Eastern Regions, with SAP 10116371 then being used on the neutral conductor.

^{d/} Use on 4 kV in extreme contamination areas along beach (with steel pin and spring washer).

Note(s):

1. See [DC 535](#) for Wildlife Protection standards.
2. Do not install upside down.
3. Not for use with covered conductor.
4. On 12 foot dead-end arm (4" x 6"), use 7-1/2 inch Long Shank Pin (SAP 10068281).

Scope GR 200.2 Polymer Pin-Type Line Insulators — Tie Top

Figure GR 200–2: Polymer Pin Type Insulators — Tie Top

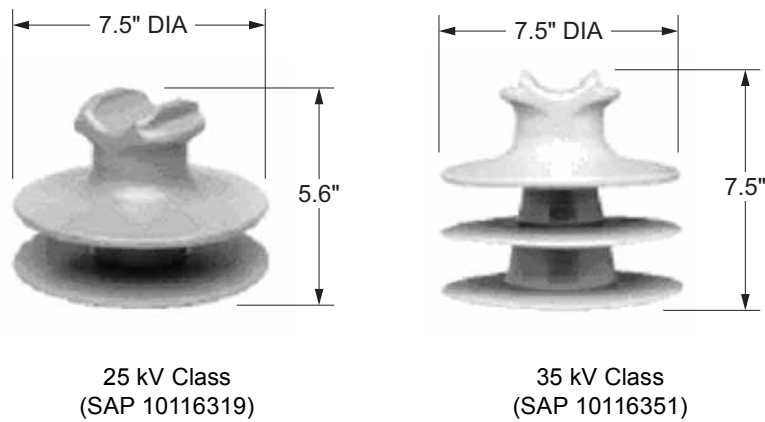

Note(s):

1. For Polymer Pin-Type Installation details see Scope [GR 200.3, Section 2.0](#).

Table GR 200–2: Polymer Pin-Type Insulators — Tie Top

Line Voltage (kV)	Insul. Area	Nom. kV Rating	Pin-Type Insulators	Insulator Pins	
			SAP	Vertical Pin SAP	Angle Pin SAP
33	A, B, C	35	10116351	10068306	10068299
16	A, B, C	35	10116351	10068303	10068299
	Neutral	25 ^{a/}	10116319	10068303	10068299
4 and 12	A, B, C	25	10116319	10068303	10068299
	Neutral	25 ^{a/}	10116319	10068303	10068299

^{a/} The same nominal kV rated insulator can be used on all conductors provided that the Neutral is identified with an "N" sign (SAP 10135124).

Note(s):

1. To be used with the Universal Conductor Clamp (see [CO 510](#)).
2. See [DC 535](#) for Wildlife Protection standards.
3. Not to be used for installations where there is an upward vertical strain. Use Post Type insulators instead (see [GR 205](#)).
4. Do not install upside down.
5. 1-3/8 inch insulators can be used with a 1-inch pin and adapter (SAP 10068613).
6. Not for use with covered conductor.
7. On 12 foot dead-end arm (4" x 6"), use 7-1/2 inch Long Shank Pin (SAP 10068281).

Approved by: <i>ajf</i>	Pin-Type Line Insulators	GR 200
Effective Date: 01-25-2019	What's Changed?	Sheet 3 of 8
		DOH

Scope GR 200.3 Polymer Pin-Type Line Insulators — Vice-Top, Aluminum Inserts

Figure GR 200–3: Polymer Pin-Type Insulators — Vice-Top, Aluminum Inserts (For Use with Aluminum Conductor)



25 kV Class
(SAP 10181690)



35 kV Class
(SAP 10181692)

Note(s):

1. For Polymer Pin-Type Installation details see Scope [GR 200.6, Section 2.0](#).

Table GR 200–3: Polymer Pin-Type Insulators — Vice-Top, Aluminum Inserts

Line Voltage (kV)	Insul. Area	Nom. kV Rating	Pin-Type Insulators	Insulator Pins	
			SAP	Vertical Pin SAP	Angle Pin SAP
33	A, B, C	35	10181692	10068306	10068299
16	A, B, C	35	10181692	10068306	10068299
	Neutral	25 ^{a/}	10181690	10068306	10068299
4 and 12	A, B, C	25	10181690	10068306	10068299
	Neutral	25 ^{a/}	10181690	10068306	10068299

^{a/} The same nominal kV rated insulator can be used on all conductors provided that the Neutral is identified with an "N" sign (SAP 10135124).

Note(s):

1. Vice-Top Polymer Insulators with Aluminum inserts shall only be used for bare aluminum conductor.
2. See [DC 535](#) for Wildlife Protection standards.
3. Not to be used for installations where there is an upward vertical strain. Use Post Type insulators instead (see [GR 205](#)).
4. Do not install upside down.
5. 1-3/8 inch insulators can be used with a 1-inch pin and adapter (SAP 10068613).
6. Do not reuse nylon torque bolts; replace with SAP 10116757 for Hendrix, SAP 10210141 for Preformed Line Products.
7. Not for use with covered conductor.
8. On 12 foot dead-end arm (4" × 6"), use 7-1/2 inch Long Shank Pin (SAP 10068281).

GR 200	Pin-Type Line Insulators	Approved by: <i>ajf</i>
		Effective Date: 01-25-2019
Sheet 4 of 8	What's Changed?	
DOH		

Scope GR 200.4 Polymer Pin-Type Line Insulators — Vice-Top, Bronze Inserts

Figure GR 200–4: Polymer Pin-Type Insulators — Vice-Top, Bronze Inserts (For Use with Copper Conductor)



25 kV Class
(SAP 10181691)



35 kV Class
(SAP 10181693)

Note(s):

1. For Polymer Pin-Type Installation details see Scope [GR 200.6, Section 2.0](#).

Table GR 200–4: Polymer Pin-Type Insulators — Vice-Top, Bronze Inserts

Line Voltage (kV)	Insul. Area	Nom. kV Rating	Pin-Type Insulators	Insulator Pins	
			SAP	Vertical Pin SAP	Angle Pin SAP
33	A, B, C	35	10181693	10068306	10068299
16	A, B, C	35	10181693	10068306	10068299
	Neutral	25 ^{a/}	10181691	10068306	10068299
4 and 12	A, B, C	25	10181691	10068306	10068299
	Neutral	25 ^{a/}	10181691	10068306	10068299

^{a/} The same nominal kV rated insulator can be used on all conductors provided that the Neutral is identified with an "N" sign (SAP 10135124).

Note(s):

1. Vice-Top Polymer Insulators with Bronze inserts shall only be used for bare copper conductor.
2. See [DC 535](#) for Wildlife Protection standards.
3. Not to be used for installations where there is an upward vertical strain. Use Post Type insulators instead (see [GR 205](#)).
4. Do not install upside down.
5. 1-3/8 inch insulators can be used with a 1-inch pin and adapter, SAP 10068613.
6. Do not reuse nylon torque bolts; replace with SAP 10116757 for Hendrix, SAP 10210141 for Preformed Line Products.
7. Not for use with covered conductor.
8. On 12 foot dead-end arm, (4" x 6"), use 7-1/2 inch Long Shank Pin (SAP 10068281).

Approved by: <i>ajf</i>	Pin-Type Line Insulators	GR 200
Effective Date: 01-25-2019	What's Changed?	Sheet 5 of 8
		DOH

Scope GR 200.5 Polymer Pin-Type Line Insulators — Vice-Top, Nylon Inserts

Figure GR 200–5: Polymer Pin-Type Insulators — Vice-Top, Nylon Inserts (For Use with Insulated or Covered Conductor ONLY)

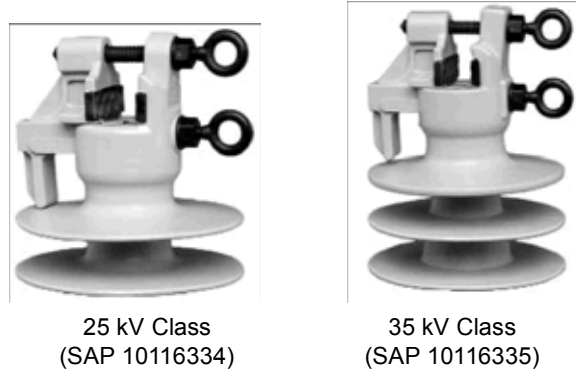

Note(s):

- For Polymer Pin-Type Installation details see Scope [GR 200.6, Section 2.0](#).

Table GR 200–5: Polymer Pin-Type Insulators — Vice-Top, Nylon Inserts

Line Voltage (kV)	Insul. Area	Nom. kV Rating	Pin-Type Insulators	Insulator Pins	
			SAP	Vertical Pin SAP	Angle Pin SAP
33	A, B, C	35	10116335	10068306	10068299
16	A, B, C	35	10116335	10068306	10068299
	Neutral	25 ^{a/}	10116334	10068306	10068299
4 and 12	A, B, C	25	10116334	10068306	10068299
	Neutral	25 ^{a/}	10116334	10068306	10068299

^{a/} The same nominal kV rated insulator can be used on all conductors provided that the Neutral is identified with an “N” sign (SAP 10135124). If the same insulator is used on all conductors (A, B, C, and Neutral), the “N” sign shall be used on every crossarm to identify the neutral.

Note(s):

- Vice-Top Polymer Insulators with Nylon inserts shall only be used for insulated (covered) conductor.
- See [DC 535](#) for Wildlife Protection standards.
- Not to be used for installations where there is an upward vertical strain. Use Post Type insulators instead (see [GR 205](#)).
- Do not install upside down.
- 1-3/8 inch insulators can be used with a 1-inch pin and adapter (SAP 10068613).
- Do not reuse nylon torque bolts; replace with SAP 10116757 for Hendrix, SAP 10210141 for Preformed Line Products.
- On 12 foot dead-end arm, (4" × 6"), use 7-1/2 inch Long Shank Pin (SAP 10068281).

GR 200	Pin-Type Line Insulators	Approved by: <i>ajf</i>
		Effective Date: 01-25-2019
Sheet 6 of 8	What's Changed? Updated Table GR 200–5, footnote a/.	
DOH		

Scope GR 200.6 Pin-Type Insulator Installation Instructions

1.0 Porcelain Pin-Type Insulator Installation Instructions

- 1.1 Install insulator onto pin threads.
- 1.2 Rotate insulator clockwise until resistance is felt.
- 1.3 Now turn the insulator clockwise to align the top saddle or clamp-top with the conductor a maximum of 1/2 turn.
- 1.4 For Tie-top insulators:
 - Place conductor in the saddle and tie securely.
- 1.5 For Clamp-top insulators:
 - Place conductor in the clamp and tighten bolt.

Note(s):

- 1. Do not install upside down.

2.0 Polymer Pin-type Insulator Installation Instructions

- 2.1 Install insulator onto pin threads.
- 2.2 Rotate insulator clockwise 4 to 5-1/2 complete turns.
- 2.3 The insulator pin threads will make contact with the mastic in the insulator threads as it is tightened. It is normal for the insulator to rotate counter-clockwise when released due to the pressure created by the mastic in the threads.
- 2.4 Now turn the insulator clockwise to align the top saddle or clamp-top with the conductor a maximum of 1/2 turn.
- 2.5 For Tie-Top insulators:
 - Place conductor in the saddle and tie securely.
- 2.6 For Vice-Top insulators:
 - Place conductor in the vise and tighten bottom bolt first.
 - The torque bolts are designed to break when the required torque is achieved.
 - DO NOT USE THE SIDE POSITION FOR ANY REASON.

Note(s):

- 1. Do not tighten polymer pin-type insulators more the 6 complete turns.
- 2. Do not install upside down.

Approved by: <i>ajf</i>	Pin-Type Line Insulators	GR 200	
Effective Date: 01-25-2019	What's Changed?	Sheet 7 of 8	DOH

Scope GR 200.7 Polymer Pin Type Line Insulators — Clamp Top with Universal Inserts

Figure GR 200-6: Polymer Pin Type Insulators — Clamp Top with Universal Inserts

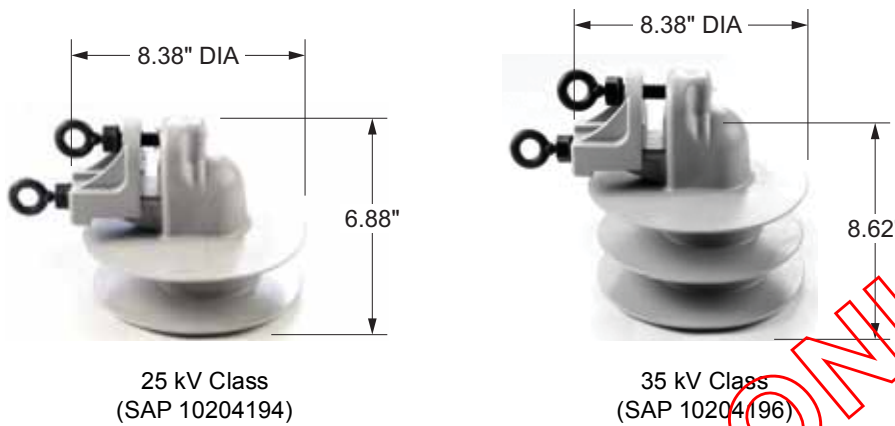

Note(s):

1. Clamp top insulators with universal inserts are approved for AL, CU and covered conductors.
2. For Polymer Pin-Type Installation details see Scope [GR 200.6, Section 2.0](#).

Table GR 200-6: Polymer Pin Type Insulators — Clamp Top with Universal Inserts

Line Voltage (kV)	Insul. Area	Nom. kV Rating	Pin-Type Insulators	Insulator Pins	
			SAP	Vertical Pin SAP	Angle Pin SAP
33	A, B, C	35	10204196	10068306	10068299
16	A, B, C	35	10204196	10068306	10068299
	Neutral	25 ^{a/}	10204194	10068306	10068299
4 and 12	A, B, C	25	10204194	10068306	10068299
	Neutral	25 ^{a/}	10204194	10068306	10068299

^{a/} The same nominal kV rated insulator can be used on all conductors provided that the Neutral is identified (SAP 10135124).

Note(s):

1. See [DC 535](#) for Wildlife Protection standards.
2. Not to be used for installations where there is an upward vertical strain. Use Post Type insulators instead. See [GR 205](#).
3. Do not install upside down.
4. 1-3/8 inch insulators can be used with a 1-inch pin and adapter (SAP 10068613).
5. Do not reuse nylon torque bolts; replace with SAP 10116757.

DOH-PO: Poles and Guying

TABLE OF CONTENTS

<u>STANDARD</u>	<u>TITLE</u>
PO 100	Poles — General Information
PO 100.1	Wood Poles
PO 100.2	Steel Poles
PO 100.3	Handling and Framing of Wood and Steel Poles
PO 100.4	Step Length for Poles by Pole Length
PO 100.5	Setting and Removing for Wood Poles
PO 100.6	Dimensions and Weights for Wood and Steel Poles
PO 105	Temporary Cover for Pre-Dug Pole Holes
PO 105.1	Temporary Cover for Pre-Dug Pole Holes
PO 110	Pole Steps on Subtransmission Wood Poles
PO 110.1	Pole Steps on Subtransmission Wood Poles with Distribution Risers and/or Apparatus
PO 112	Composite Poles
PO 112.1	General Information
PO 112.2	Handling, Setting, and Framing
PO 112.3	Assembly and Removal
PO 112.4	Composite Pole Reference
PO 115	Temporary Attachment of Pole Sections with Third-Party Facilities to Composite Poles
PO 115.1	Temporary Attachment of Wood Pole Sections with Third-Party Facilities to Composite Poles
PO 120	Pole Numbering, Marking, and HIGH VOLTAGE Signs
PO 120.1	Typical Pole Numbering
PO 120.2	Pole Marking Using Brands, Metal Bands, Visibility Strips and High Voltage Signs
PO 121	Phasing Identification Labeling
PO 121.1	Pole Labeling
PO 130	Pole-Key and Block Support
PO 130.1	Pole-Key and Block Support
PO 140	Pole, Temporary Wood Stubbing/Straightening
PO 140.1	Pole, Temporary Wood Stubbing/Straightening
PO 140.2	Use of Pole Set-Urethane Foam for Pole Reinforcement
PO 141P	Star Pole Anchor Pilot
PO 141P.1	Star Pole Anchor Pilot
PO 142	Pole Push Brace
PO 142.1	Method of Installing a Push Brace
PO 143	Caisson Installation
PO 143.1	Caisson and Sono Tube General Information

Approved by: <i>ajf</i>	Poles and Guying Table of Contents	PO
Effective Date: 01-25-2019		Sheet 1 of 2
		DOH

STANDARD	TITLE
PO 145	Modular Pole Butt Replacement for Damaged Poles, Pole Relocation
PO 145.1	Modular Pole Butts
PO 145.2	Step-By-Step Procedure for Installing Mod-Pole
PO 145.3	Grout and Pea Gravel Requirements for Modular Pole Butts
PO 147	Reinforcement and Replacement of Deteriorated Poles
PO 147.1	Ground Line Reinforcement of Wood Poles
PO 150	Pole Top Extensions
PO 150.1	Applications for Pole Top Extensions
PO 200	Grade "A" Crossing General Requirements
PO 200.1	Grade "A" Crossing
PO 200.2	Grade "A" Crossing General Requirements
PO 300	Guying — General Information
PO 300.1	Guying — General Information
PO 300.2	Anchors for Guys
PO 300.3	Pole Bands for Guying Composite Poles
PO 310	Power-Installed Screw Anchors
PO 310.1	Heavy-Duty Power-Installed Screw Anchors (PISA)
PO 310.2	Holding Strength Calculations for PISA Anchors
PO 315	Guying Components
PO 315.1	Guying Components
PO 320	Determination of Anchor/Guy Size
PO 320.1	Instructions for Use of Guy Requirement Tables
PO 320.2	Conductor Dead-End Tensions for the Determination of Anchor/Guy Size
PO 330	Determination of Anchor Deviation Angle
PO 330.1	Determination of Anchor Deviation Angle
PO 340	Types of Guying
PO 340.1	Types of Guying
PO 340.2	Typical Installation of Rock Anchor Guying and Sidewalk Anchor Guying
PO 340.3	Typical Guying for Grades A and B Construction
PO 340.4	Maximum Conductor Tension for Guy Wires — Grade B Construction
PO 350	Guy Guards
PO 350.1	Approved Guy Guards, Application, and Installation Information
PO 360	Guying Subtransmission Lightweight Steel Poles
PO 360.1	Installation of Guy Hardware on Lightweight Steel Poles
PO 370	Composite Pole Hardware
PO 370.1	Composite Pole Hardware

PO 130 Pole-Key and Block Support

Scope PO 130.1 Pole-Key and Block Support

1.0 Application

- 1.1 The pole key is recommended for keying wood poles used in street lighting, or as a pole reinforcement in soft soils where the load is unbalanced.
- 1.2 Breast blocks and pole keys shall not be used where the slack span configuration resisting moments tabulated below are exceeded.
- 1.3 For angle limitations apply the resultant pull of conductors at various deviation angles.
- 1.4 For usable pole strengths in grade A or grade B construction, refer to pole size, strength, and weight.

Figure PO 130-1: Equations

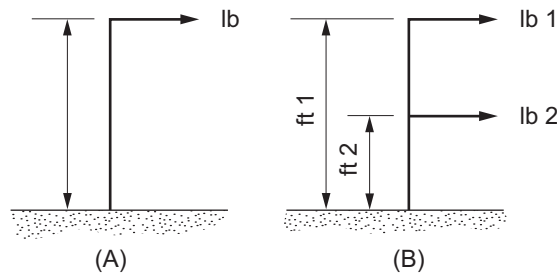

(A) $ft \times lb = ft - lb$
 (B) $(ft_1 \times lb_1) + (ft_2 \times lb_2) = ft - lb$

Table PO 130-1: Resisting Moment Applications

Type of Soil		Resisting Moment ^{a/} (ft/lb)
Class	Description	
3	Shale, Broken Red Rock, Hardpan, Compact Clay-Gravel Mixtures	55,125
4	Gravel, Compact Gravel and Sand, Claypan	47,500
5	Medium-Firm Clay, Loose Sand and Gravel, Compact Coarse Sand	36,750
6	Soft Plastic Clay, Loose Coarse Sand, Clayey Silt, Compact Fine Sand	28,875

^{a/} Resisting moment is due to combined effects of adding pole key and breast block support elements and a standard pole embedment of 10 percent of pole length + 2 feet.

Note(s):

- 1. For a unguyed reduced tension span, the corresponding pole's new imposed ground line moments shall be demonstrated to be adequately resisted without the use of a breast block-pole key configuration.

Approved by: <i>ajf</i>	Pole-Key and Block Support	PO 130
Effective Date: 01-25-2019	What's Changed?	Sheet 1 of 2
		DOH

2.0 Installation Instructions

- 2.1 Screw a 3/4-inch anchor rod into base of pole-key.
- 2.2 Drop the pole-key into hole, at base of pole, on opposite side of the applied strain. See [Figure PO DOH-2.1](#).
- 2.3 Expand pole-key with tamping bar into solid earth. See [Figure PO 130-2.2](#).
- 2.4 The pole-key must be fully expanded to insure a maximum bearing surface.
- 2.5 When the pole-key is fully expanded, see [Figure PO 130-2.3](#), the anchor rod is removed and the hole filled and tamped.

Figure PO 130-2: Methods of Self-Sustaining Pole with Breast Block and Pole-Key

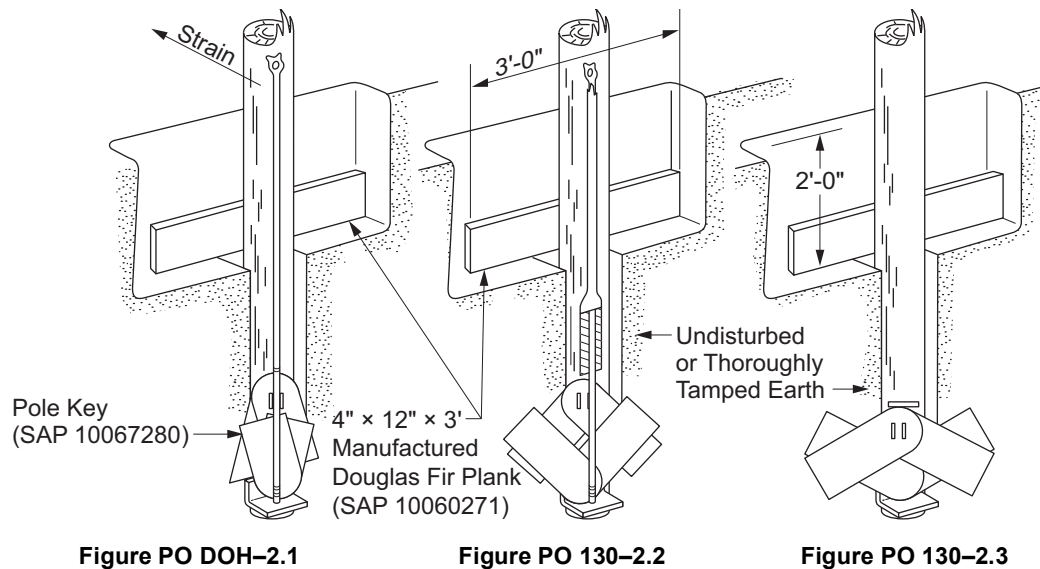

PO 130

Pole-Key and Block Support

Approved by:

a/j

Sheet 2 of 2

What's Changed? Section 2.6 and Figure PO 130-2.3 have been updated for clarity.

Effective Date:

DOH

01-25-2019

PO 310 Power-Installed Screw Anchors

Scope PO 310.1 Heavy-Duty Power-Installed Screw Anchors (PISA)

The standard for anchoring is “Heavy-Duty Power Installed Screw Anchors.” These anchors have 1-1/2-inch hubs compared to the old type screw anchor with 1-3/8-inch hubs. The 1-1/2-inch hub anchor will withstand considerably more installation torque and can, therefore, be used in more areas of the company. Plate anchors will continue to be used in extremely loose soil, inaccessible areas, or rock bed areas.

1.0 Tooling

A line truck should be equipped with a heavy-duty PISA wrench (SAP 10148222 or SAP 10148223, and SAP 10148225), and a new drive end assembly (SAP 10148716) (used for 1-1/2-inch hub anchors). Torque indicator (SAP 10144863) should be used for installing the new heavy duty anchors for predicting the anchor performance (see [Table PO 310–2](#)).

2.0 Anchor Ordering Information

Table PO 310–1: Power Installed Screw Anchors

	Size Helix	Torque Rating (lb)	SAP	Hub (in)
Light Duty	8 single ^{a/}	4,000	10067284	1-3/8
	8 double ^{a/}	4,000	10067286	1-3/8
Heavy Duty	10 double ^{a/}	4,000	Pending	1-3/8
	8 single	7,000	10067288	1-1/2
	8 double	7,000	10067290	1-1/2
	10 double	5,000	Pending	1-1/2
Granite Anchor	4 single	7,000	10067287	1-1/2
	4 double	7,000	Pending	1-1/2

^{a/} All 1-3/8-inch hub PISA are Key 06 (not to be repurchased)

3.0 Torque Indicator Operating Instructions

- 3.1 Install the torque indicator between the appropriate flanged kelly bar adaptor and the locking dog assembly (see [Figure PO 310–1](#)).
- 3.2 Install indicator so that the plate with built-in nut assembly will be toward the kelly bar.
- 3.3 Check freedom of unit by rotating bottom plate with respect to top plate.
- 3.4 The edge of each plate has an indented mark accented with a painted line. Rotate plate to bring these index marks into alignment with each other. These marks must be aligned before each loading for proper operation (see [Figure PO 310–1](#)).

Approved by: 	Power-Installed Screw Anchors	PO 310
Effective Date: 01-25-2019	What's Changed?	Sheet 1 of 7
		DOH

- 3.5 Determine the minimum torque value needed for anchor installation. See examples for calculating holding strength [PO 310.2 \(Sheet 5\)](#).
- 3.6 Load the unit with the correct number of pins for the torque value wanted. Place approximately equal number of pins in opposing sectors of torque indicator (see [Figure PO 310-1](#)).
- 3.7 Eye of rod shall be 6 inches minimum and 18 inches maximum above finished grade measured along rod (with new installation).

Note: Do not install more pins exceeding torque value of anchor or equipment driving anchor than is necessary. Fourteen pins maximum for 7,000 lb anchor (1-1/2 inch hub).

- 3.8 Install anchor until pins shear. Reload unit with the original number of pins plus two (not to exceed maximum torque recommendation for anchor) and drive anchor at least two additional feet into soil. Also drive the anchor so that the end is approximately the correct distance out of the ground.
- 3.9 Reload the unit with original number of pins. If anchor is still in the same type of soil or better, the pins will shear and anchor is installed to the minimum torque value required. If a single helix is driven past a strata of hard soil into soft soil, the pins may not shear and it will be necessary to remove the anchor and install a double helix anchor. The correct amount of pins or more should shear.
- 3.10 Install anchor so that the rod is in alignment with the guys.
- 3.11 For multiple anchor installations, it is necessary for the anchors to be properly spaced to prevent failure. The minimum distance that the anchors shall be spaced apart from each other is four times the helix diameter. For example, two-8 inch anchors, the minimum spacing between the two shall be 32 inches.

PO 310 <small>Sheet</small> 2 of 7 DOH	Power-Installed Screw Anchors	Approved by: <i>ajf</i>
	What's Changed? Section 3.7 was updated for clarity.	Effective Date: 01-25-2019

Table PO 310–2: Installing Torque Versus Holding Strengths

Table Note: The torque indicator enables anchors to be installed to a predetermined torque value which gives a positive indication of the holding strength of the anchor in any type of soil. The torque indicator will prevent excessive torque on the anchor during installation, thus preventing fracture and loss of the anchor.

Type of Anchors	Torque (in Minimum Pins Sheared)			Anchor Assembly Load Rating (lbs)	Guideline for Guys ^{a/}
	8-Inch Single	8-Inch Double	10-Inch Double		
Power Installed Screw Anchors (PISA)				Allowable New (S.F. = 2)	
1-3/8" or 1-1/2" Anchor Hub	3	2	2	5,000	1-9/32"
	7	5	4	10,000	2-9/32", or 1-3/8", or 1-7/16"
1-1/2" Anchor Hub Only	9	8	7	15,000	3-9/32", or 1-9/32" & 1-3/8", or 1-9/32" & 1-7/16"
	12	10	9	18,000	2-3/8" & 1-7/32", or 1-3/8" & 2-9/32", or 1-3/8" & 1-7/16"
4" Granite Anchors		4-Inch Single	4-Inch Double		
		9		10,000	2-9/32", or 1-3/8", or 1-7/16"
		10		15,000	3-9/32", or 1-9/32" & 1-3/8", or 1-9/32" & 1-7/16"
		12	12	18,000	2-3/8" & 1-7/32", or 1-3/8" & 2-9/32", or 1-3/8" & 1-7/16"
Cross-Plate Anchors	Anchor Rod and Plate				
	5/8" × 6' Single Eye ^{b/}			8,000	1-3/8"
	3/4" × 8' Double Eye ^{b/}			11,500	2-9/32" or 1-3/8" or 1-7/16"
	1" × 10' Triple Eye ^{b/}			18,000	2-3/8" or 3-9/32" or 1-7/16" and 1-3/8"
	1-1/4" × 10' Triple Eye ^{b/}			29,000	2-7/16" or 3-3/8" or 2-3/8" and 1-9/32"
Expanding Rock	3/4" × 15" Double Eye			11,500	2-9/32" or 1-3/8" or 1-7/16"

^{a/} Guy recommendations are guidelines to insure that the anchor can support the full strength capability of the guys.

^{b/} Where a backhoe is used to dig holes for plate anchor, each anchor shall be limited to a working load of 11,500 lb.

Note(s):

- Anchors shall have the same safety factor requirements as the guys they support (2.0 for new).
- PISA anchors shall be installed with a minimum spacing of 4 times the largest helix. For example, two-8 inch anchors, the minimum spacing between the two shall be 32 inches.
- It is recommended that there be a minimum of 6 feet of spacing between the plate anchors. If the recommended spacing can't be obtained, then the following criteria shall be used:
 - 4 feet for installations up to 10,000 lb new
 - 5 feet for installations up to 15,000 lb new
 - 6 feet for installations greater than 15,000 lb new
- See PO 320, Table 8 for placement of anchor plate relative to anchor eye rod.
- For multiple backhoe installations, trenches should be perpendicular to guy wire.

Approved by: 	Power-Installed Screw Anchors	PO 310
Effective Date: 01-25-2019	What's Changed?	Sheet 3 of 7
		DOH

4.0 Loading Pins

Each individual pin has a shearing value of 500 foot-pounds. As the above chart indicates, a predetermined amount of pins sheared will predict the holding strength of the anchor. Pins may be ordered by boxes of 1,800 (SAP 10148739).

PO 310	Power-Installed Screw Anchors	Approved by: <i>ajf</i>
Sheet 4 of 7	What's Changed?	Effective Date:
DOH		01-25-2019

Scope PO 310.2 Holding Strength Calculations for PISA Anchors

The necessary holding strength shall be determined by the number and size of down guys to be attached to the anchor.

Example:

1. One 3/8-inch and one 9/32-inch E.H.S. guys are to be attached to an anchor. What holding strength should the anchor have?

Ans. See [PO 320](#) — The total conductor pull at a level angle is the rated guy strength with a safety factor of 2 (working tension), so that 1-3/8-inch E.H.S. guy has a working tension of 7,700 lb, and 1-9/32-inch guy has a working tension of 4,475 lb. The total holding strength for the anchor should be the sum of the rated working tensions of both guys, or 7,000 lb + 4,475 lb = 12,175 lb. A screw anchor installed with a holding strength above 12,175 lb should be used (see [Table PO 310–2](#)).

2. One 3/8-inch and two 9/32-inch E.H.S. guys are to be installed on an anchor. (The maximum amount allowed on a triple eye rod per [PO 320](#).) What holding strength should the anchor have?

Ans. Per [PO 320](#), the full rated working tension for guys with a safety factor of two is found under level angle. 1-3/8-inch E.H.S. = 7,700 lb and two 9/32-inch E.H.S. —
4,475 lb × 2 = 8,950 lb. The total pull will be 7,700 lb + 8,950 lb = 16,650 lb.

In accordance with [Table PO 310–2](#), an anchor with a holding strength above 16,650 lb should be used. Therefore, a single 8-inch PISA should shear 12 loading pins, a double 8-inch PISA should shear 10 loading pins, or a double 10-inch PISA should shear 9 loading pins upon installation.

Approved by: 	Power-Installed Screw Anchors	PO 310
Effective Date: 01-25-2019	What's Changed?	Sheet 5 of 7 DOH

Figure PO 310-1: Power Installed Screw Anchors



Double Helix Anchor

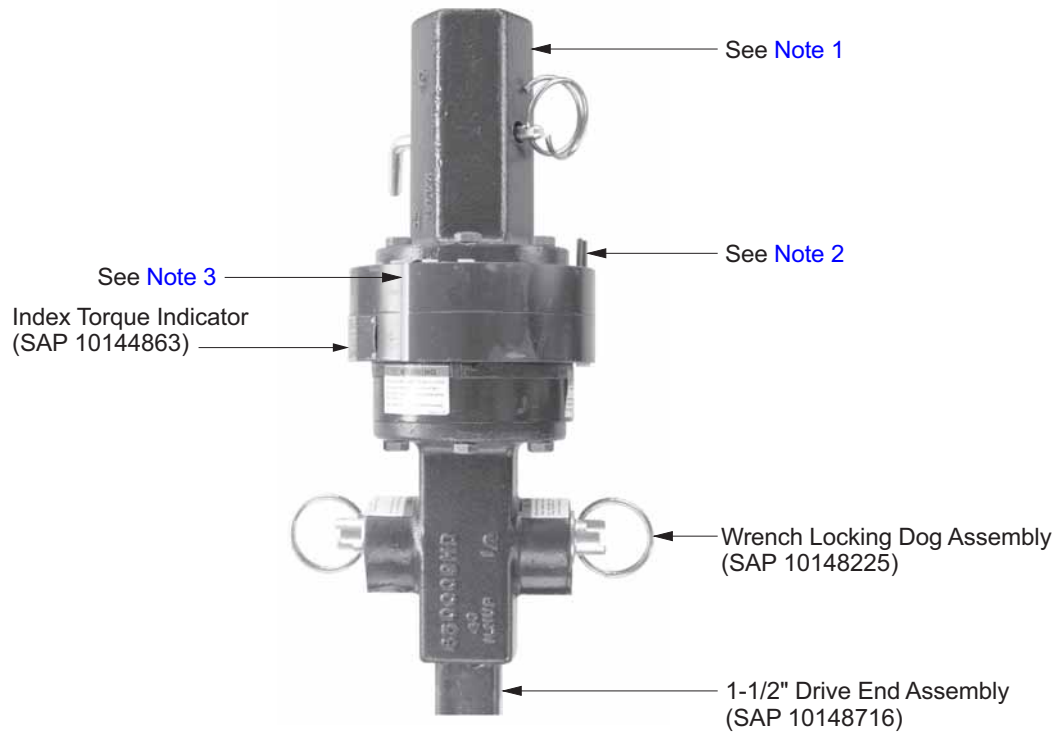

Single Helix Anchor

Note(s):

1. Kelly bar adapter 2" hex shaft (SAP 10148222) 2-5/8" hex shaft (SAP 10148223) ([See Note 3.1 \[Sheet 1\].](#))
2. Loading pins (SAP 10148739) ([See Note 3.6 \[Sheet 2\].](#))
3. Index marks on torque indicator ([See Note 3.4 \[Sheet 1\].](#))

Approved by: 	Power-Installed Screw Anchors	PO 310
Effective Date: 01-25-2019	What's Changed?	Sheet 7 of 7 DOH

This page intentionally left blank.

PO 350 Guy Guards

Scope PO 350.1 Approved Guy Guards, Application, and Installation Information

Figure PO 350-1: Plastic “Snapper” Guy Guard

SAP 10067752—(Preferred)
Color—Yellow

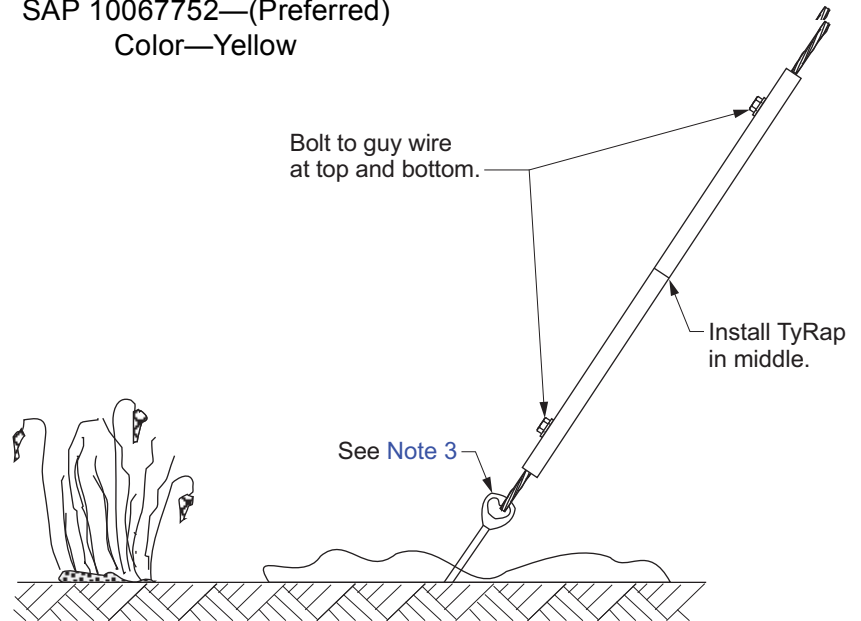
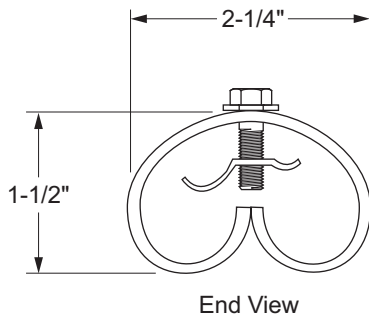

Application

1. All new and rebuild construction (except in Fire Clearing Area).
2. Use Steel Guy Guard in areas requiring Fire Clearings.

Figure PO 350-2: Half Round Plastic Guy Guard

SAP 10067972—(Alternate)
Color—Gray

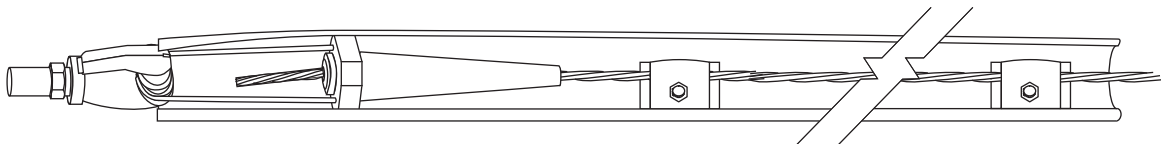

Application

1. New sidewalk anchor guys and replacement of damaged Guy Guards.
2. Use Steel Guy Guard in areas requiring Fire Clearings.
3. Entire eye of the rod shall be a minimum of 6 inches and a maximum of 18 inches above finished grade measured along the rod.

Approved by: <i>a/j</i>	Guy Guards	PO 350
Effective Date: 01-25-2019	What's Changed?	Sheet 1 of 2
		DOH

Figure PO 350-3: Tubular PVC Guy Guard

SAP 10067970—Assembly includes Guard and Wedge (Alternate)
Color—Gray

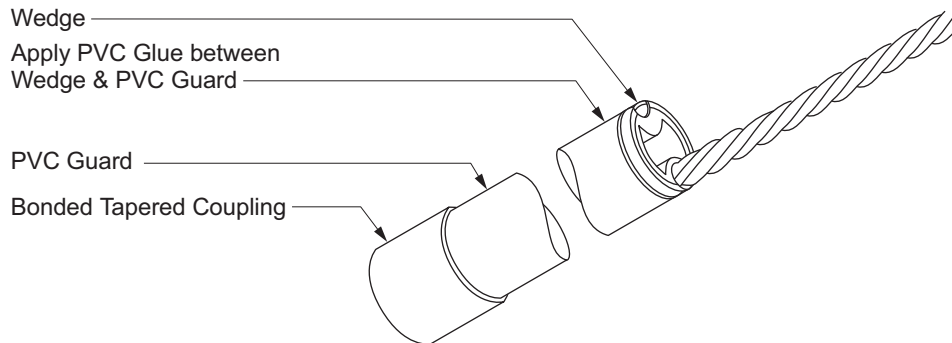

Application

On all new and rebuild construction it is necessary to place the guard on the guy wire prior to tensioning. Install PVC wedge after guard is in place.

Note(s):

1. A parallel groove connector shall be installed above the wedge where a preformed dead-end is used at the bottom of the guy. An automatic dead-end is preferred at the anchor end.
2. One-inch sch 40 PVC may be substituted for the tubular PVC guard. A parallel groove connector shall be installed on the guy above the end of PVC conduit.
3. Use steel guy guard in areas requiring fire clearings.

Figure PO 350-4: Half Round Steel Guy Guard

SAP 10067971

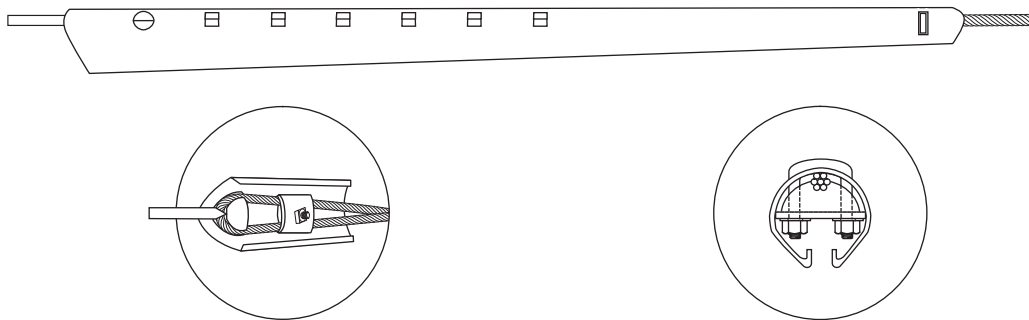

Bottom Clamp Detail

Top Clamp Detail

Application

Steel guy guards shall be used in areas requiring fire clearings.

PO 360 Guying Subtransmission Lightweight Steel Poles

Scope PO 360.1 Installation of Guy Hardware on Lightweight Steel Poles

Figure PO 360-1: Installation of Guy Hardware on Lightweight Steel Poles

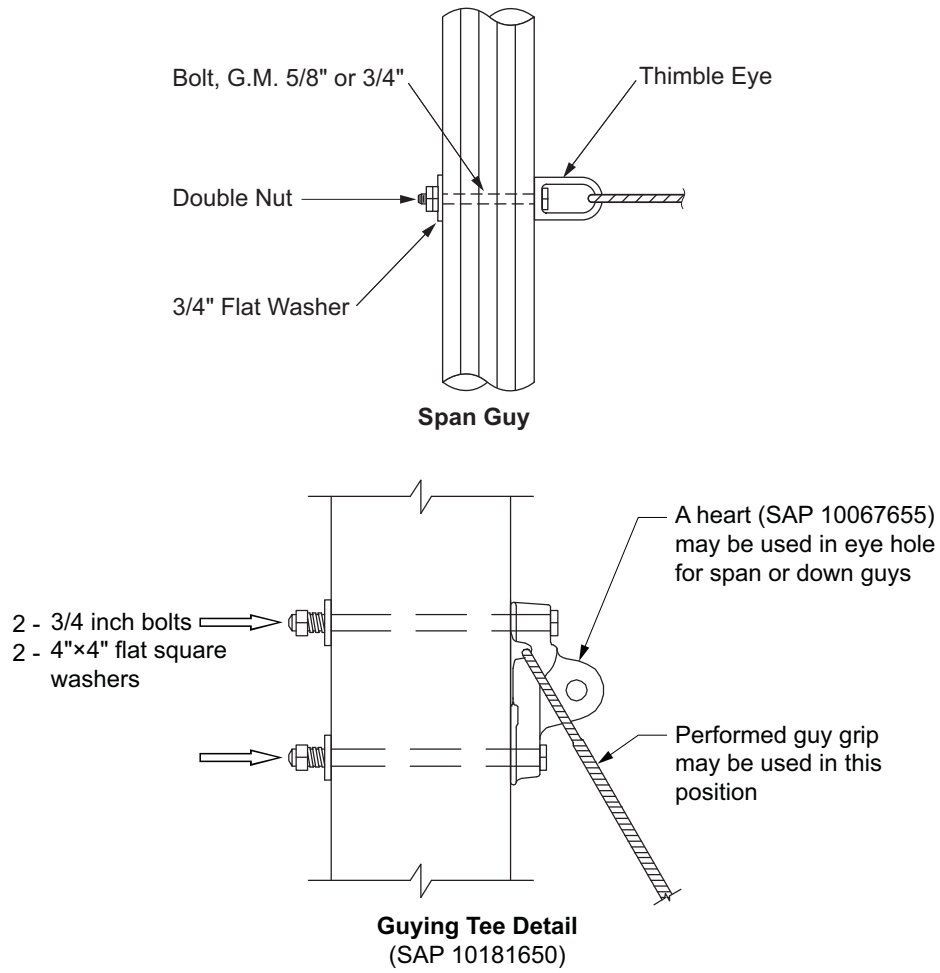

Note(s):

1. Anchor guys on LWS poles are installed without insulators.
2. Span guys between LWS poles are installed without insulators.
3. Follow the guying criteria for wood poles, including poles with communication and third party attachments, except as shown in these figures.

Approved by: 	Guying Subtransmission Lightweight Steel Poles	PO 360
Effective Date: 01-25-2019	What's Changed? Updated Figure PO 360-1.	Sheet 1 of 1 DOH

This page intentionally left blank.

PO 370 Composite Pole Hardware

Scope PO 370.1 Composite Pole Hardware

1.0 Composite Crossarms

1.1 Composite crossarms (see [Figure PO 370-1](#)) are available in sizes ranging from 5 feet to 20 feet for either heavy tangent and dead-end types for use on composite poles (see [Table PO 370-1](#)).

Composite crossarms shall be used on composite poles.

Figure PO 370-1: Heavy Duty Crossarms

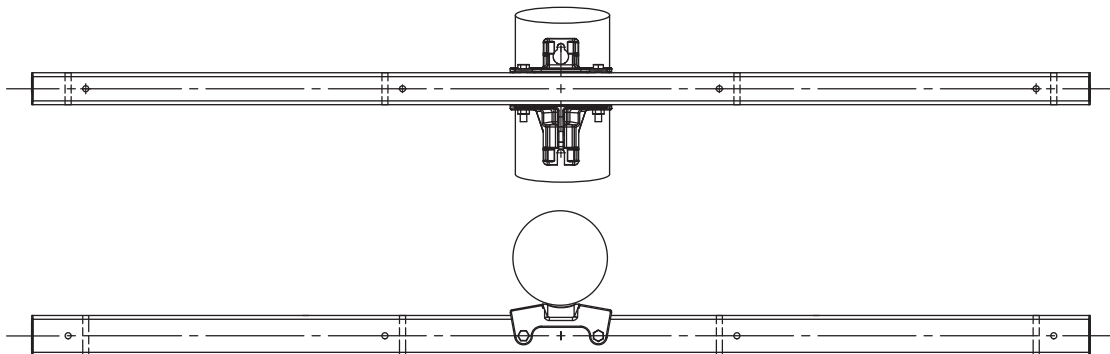

Table PO 370-1: Heavy Duty Crossarm SAP Numbers

Type	Size (ft)	SAP
Tangent	5	10211425
Tangent	8	10060793
Tangent	10	10060794
Tangent	12	10060795
Tangent	20	10208033
Dead-End	8	10060796
Dead-End	10	10060797
Dead-End	12	10060798
Dead-End	20	10208513
Tangent Alley Arm	10	10211423
Tangent Alley Arm	12	10211424

Note(s):

- For installation, application or, assembly details, see [PO 112](#).
- 8 foot and 10 foot composite crossarms dimensions are 3-5/8" x 4-5/8". 12 foot composite crossarms dimensions are 4" x 6".
- Composite crossarms include mounting assembly bracket. V-braces and back braces are not required, except on 5 foot crossarms.
- Field drilling is permissible; drilled holes shall be 2 inches MIN apart (center-to-center), 4 inches MIN from end of arm, and 15 inches MIN from center of arm except holes for vertical braces on capacitor banks and transformers. Use carbide drill bit.

Approved by: <i>ajf</i>	Composite Pole Hardware	PO 370
Effective Date: 01-25-2019	What's Changed?	Sheet 1 of 14
		DOH

1.2 Crossarm Mounting Bracket with Guy Attachment Holes

Figure PO 370–2: Composite Crossarm Mounting Bracket with Guy Attachment Holes



Guy Attachment Holes
Working Load Capacity
10,000 lb either hole

2.0 Riser Support

Figure PO 370–3: Riser Support



Table PO 370–2: Riser Support

Table Note: Attach risers as described in [PO 112](#), and refer to the Distribution Underground Construction Standards (DUG) Section CR 110.

Size	SAP
24" Extended	10073393

3.0 Pole Hole Plug

3.1 Pole hole plugs (Figure PO 370-4 and Figure PO 370-5), shall be installed in open composite pole holes per Table PO 370-3 Table PO 370-4 to prevent bugs and moisture intrusion. Only use stainless steel plugs in Bulletin 322 and/or high fire areas.

Figure PO 370-4: Plastic Pole Hole Plug



Table PO 370-3: Plastic Pole Hole Plug

Plug Size (in)	SAP
5/8	10068598
3/4	10068599
7/8	10068601
1	10068602
1-1/2	10068603

Figure PO 370-5: Stainless Steel Pole Hole Plugs



Table PO 370-4: Stainless Steel Pole Hole Plug

Plug Size (in)	SAP
11/16	10211092
13/16	10211093
1	10211094
1-1/8	10211095
1-3/8	10211194

Approved by:

ajf

Composite Pole Hardware

PO 370

Effective Date:
01-25-2019

What's Changed?

Sheet 3 of 14

DOH

4.0 Insulated Clamp for Ground Wire

For use on composite poles, use (2) #10 × 2" self-drilling screws (SAP 10071503).

Figure PO 370–6: Insulated Clamp and (2) Self-drilling Screws



Table PO 370–5: Insulated Clamp and (2) Self-drilling Screws

Description	Quantity	Size	SAP
Insulated Clamp (Grey)	1	#4-PGW	10209485
Insulated Clamp (Black)	1	#6-PGW	10209484
Self-drilling Screw	2	#10 × 2"	10071503

5.0 Bonding Clip

Figure PO 370–7: Bonding Clip



Table PO 370–6: Bonding Clip

Description	Quantity	Size	SAP
Bonding Clip	1	1/8"	10113253
Self-drilling Screw	1	#10 × 1"	10072230

6.0 Thimble Eyelet

Figure PO 370–8: Thimble Eyelet



Table PO 370–7: Thimble Eyelet

Type	Application	Size	SAP
Standard	Span Guys	5/8"	10068524
		3/4"	10068525

7.0 Pole-Top Cap

Pole-top caps (see [Figure PO 370–10](#) and [Figure PO 370–11](#)) come in various sizes and fit directly on top of the pole module. Pole caps for octagon poles are available in 10 inches.

Figure PO 370–9: Pole Top and Base Section Cap for 45-Foot Round Composite Sectional Poles



Cone Type (Top Section)

Flat Type
(Top Section for Use with Ridge Pin)
(Bottom Section — Temporary)

Approved by: <i>ajf</i>	Composite Pole Hardware	PO 370	
Effective Date: 01-25-2019		What's Changed?	Sheet 5 of 14
			DOH

Table PO 370–8: Pole Top and Base Section Cap for 45-Foot Round Composite Sectional Poles

Pole Manufacturer	Description	Cap Size	SAP
Highland	Base Section Temporary Cap	14" Flat Type	10207279
	Top Section Cap	9.5" Cone Type	10207280
	Top Section Cap	9.5" Flat Type (for use with ridge pin)	10207281
RS	Base Section Temporary Cap	14" Flat Type	10207279
	Top Section Cap	10" Cone Type	10207282
	Top Section Cap	10" Flat Type (for use with ridge pin)	10207283

Note(s):

1. Top and Base Covers are included with RS poles.

8.0 Spring Washer

Hardware for composite poles shall be tightened until the spring washer has been compressed to where the springs just touch.

Figure PO 370–10: Spring Washer



Table PO 370–9: Spring Washer

Size	SAP
3/8"	10072344
1/2"	10072345
5/8"	10072346
3/4"	10072347

9.0 Composite Pole Guying Tee

The composite pole guying tee shall be used when attaching all down guys, regardless of size, directly to composite and LWS poles. Pole guying tee shall be used when attaching 7/16th inch down guys directly to wood, composite, and LWS poles. See PO 320 (Sheet 8, Note 1). Two 3/4-inch through bolts shall be used to attach the tee to the pole. Must be used in conjunction with 4-inch curved square washers.

Figure PO 370–11: Composite Pole Guying Tee

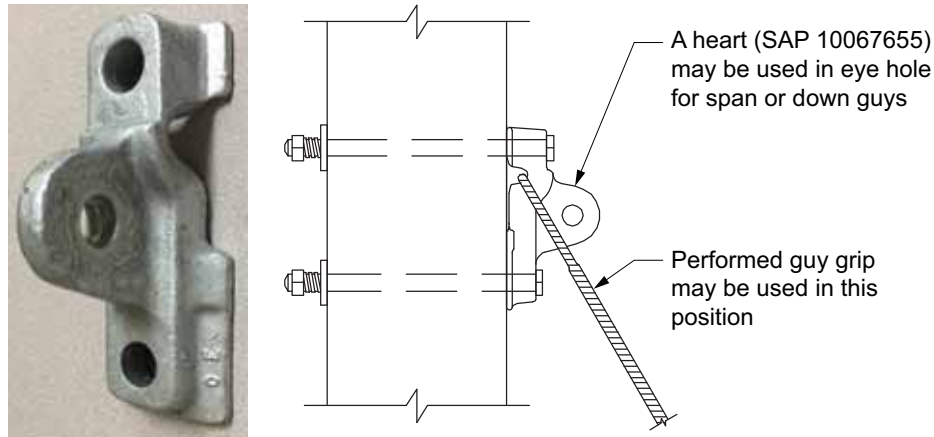

Table PO 370–10: Composite Pole Guying Tee

Maximum Working Load (lb)	SAP
10,400	10181650

10.0 Pole Plate for Sidewalk Guy

The sidewalk guy pole plate (SAP 10211422), shall be used on composite poles. Mount pole plate to pole with a 5/8 inch through bolt and spring washer. A 3 inch curved washer shall be used on the opposite side of the pole (see [Figure PO 340–5](#) for details).

Figure PO 370–12: Pole Plate



Approved by:

ajf

Composite Pole Hardware

PO 370

Sheet 7 of 14

Effective Date:
01-25-2019

What's Changed? Updated Section 9.0 and Figure PO 370–11 regarding details on use of composite pole guying tee.

DOH

11.0 Thimble Eye Bolt

Straight thimble eye bolts are to be used for span guys.

Figure PO 370–13: Thimble Eye Bolt, Straight Type



Table PO 370–11: Thimble Eye Bolt, Straight Type

Size	SAP	Strength (lb)
5/8" × 10"	10068513	13,550
5/8" × 12"	10068514	13,550
5/8" × 14"	10068512	13,550
5/8" × 16"	10068516	13,550
3/4" × 12"	10068520	20,050
3/4" × 14"	10068647	20,050

12.0 Pole Band

Figure PO 370-14: Stainless Steel Pole Band



Table PO 370-12: Stainless Steel Pole Band

Size (in)	SAP
1-1/4	10209449

13.0 Flat Square Washer

Figure PO 370-15: Flat Square Washer

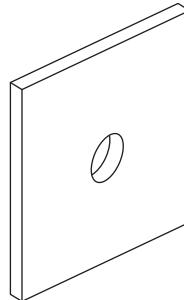

Table PO 370-13: Flat Square Washer

Size	Bolt Hole	SAP
4" x 4" x 5/16"	5/8"	10071859
4" x 4" x 5/16"	3/4"	10071861

Approved by: <i>ajf</i>	Composite Pole Hardware	PO 370	
Effective Date: 01-25-2019		What's Changed?	Sheet 9 of 14
		DOH	

14.0 Curved Square Washer

Figure PO 370–16: Curved Square Washer



Table PO 370–14: Curved Square Washer

Size	Bolt Hole	SAP
3" × 3" × 1/4"	5/8"	10071941
3" × 3" × 1/4"	3/4"	10071853
4" × 4" × 1/4"	3/4"	10071863
4" × 4" × 1/4"	7/8"	10071946

15.0 Permanent/Temporary Climbing Step

Figure PO 370–17: Permanent/Temporary Climbing Steps



Table PO 370–15: Permanent/Temporary Climbing Steps

Table Note: For installation, application or, assembly details, see [PO 112](#).

Pole	SAP
Round	10068660

16.0 Temporary Pole Step Plate

Figure PO 370–18: Temporary Pole Step Mounting Assembly



Table PO 370–16: Temporary Pole Step Mounting Assembly

Table Note: For installation, application or, assembly details see [PO 112](#).

Pole	Washer	SAP
Round	Curved	10068609

17.0 Detachable Temporary Pole Step

Figure PO 370–19: Detachable Temporary Pole Step



Table PO 370–17: Detachable Temporary Pole Step

Table Note: For installation, application or, assembly details, see [PO 112](#).

Size	SAP
5-1/2"	10068470

= FOR REFERENCE ONLY

Approved by:	Composite Pole Hardware	PO 370
Effective Date:	What's Changed?	Sheet 11 of 14
01-25-2019		DOH

18.0 Mast Arm

Figure PO 370–20: Mast Arm



Table PO 370–18: Mast Arm

Size	SAP
6'	10118507
8'	10118508
16'	10118511

19.0 Insulator Pin

Figure PO 370–21: Insulator Pin



Table PO 370–19: Insulator Pin

Pin Length (in)	Shank Length (in)	SAP	Application
7	8-1/2	10068281	12' Tangent Only
7	7 to 7-1/2	10068306	8'/10' Tangent 8'/10'/12' Dead-end
7	1-3/4	10068309	Angle or Ridge Pin

20.0 Ridge Pin Bracket

Figure PO 370–22: Ridge Pin Bracket



Table PO 370–20: Ridge Pin Bracket

Size	SAP
Universal	10067373

21.0 Protected Ground Wire

Figure PO 370–23: Protected Ground Wire



Table PO 370–21: Protected Ground Wire

Size	SAP
4 AWG	10109304
6 AWG	10109302

22.0 No Drill Zone Decal for Intelli-Pole

Figure PO 370–24: No Drill Zone Decal



Table PO 370–22: No Drill Zone Decal

Type	SAP
Arrow Up	10204661
Arrow Down	10204660

Note(s):

1. For RS Composite Poles, No Drill Zone Tag is already installed.

23.0 Visibility Strip

Figure PO 370–25: Visibility Strip



Table PO 370–23: Visibility Strip

Description	Quantity	Size	SAP
Visibility Strip	1	2" × 12"	10068488
Self-drilling Screw	2	#10 × 1"	10072230